

Hot Air Hand Dryers

Behind Mirror

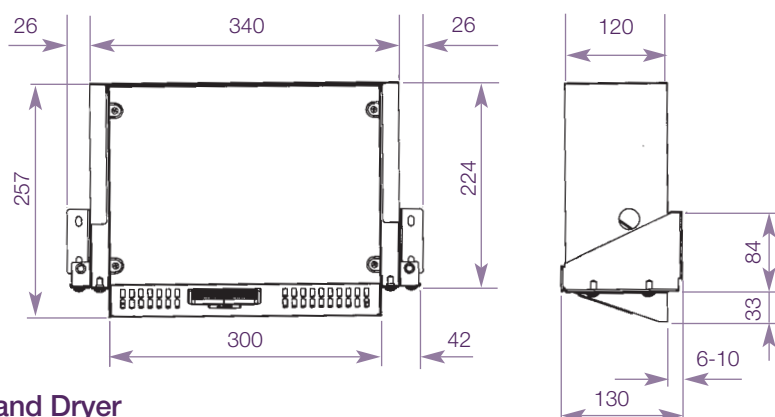
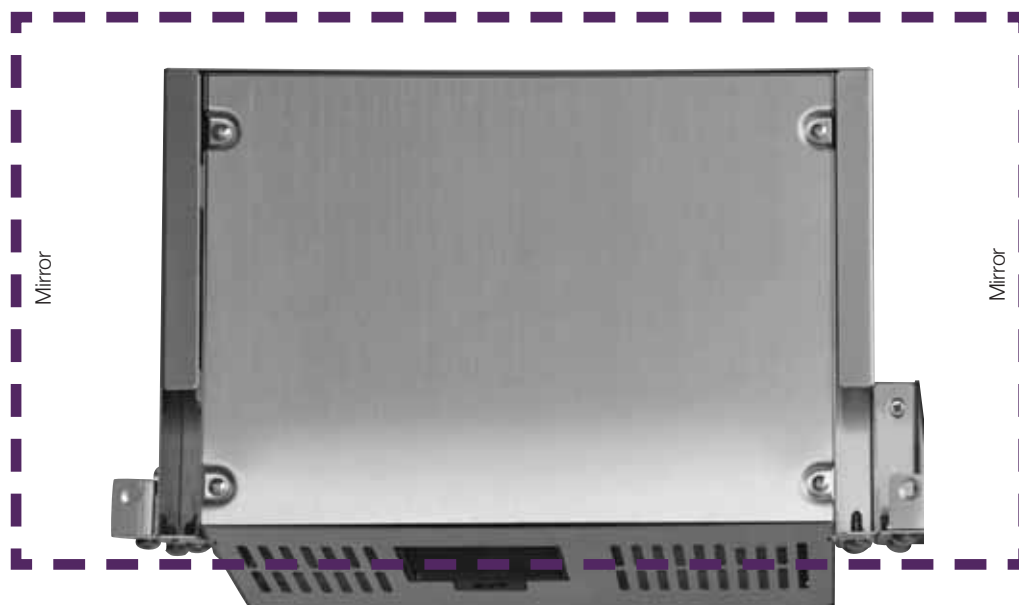

BC 5262-102 Dolphin Behind Mirror Hot Air Hand Dryer

- Suitable for high specification washrooms in airports, office blocks, schools etc...
- Tough stainless steel cover for strength and durability
- Unique restraint system allows both units to be fitted and removed from below
- Superior technical design - dual thermal overload protection on motor & heating element
- 'No touch' operation by electronic infra-red sensor maximises hygiene and economy of operation
- Infra-red sensor
- Fully automatic operation – switches off within 3 seconds of hand removal.
- 1.5mm thick stainless steel – very tough design
- 5 year manufacturer's warranty
- **Mirror not included**

Product Data

- H 257 x W 340 mm
- Projection 120mm
- IPX1 rated
- Class 1 rated isolation
- 200w induction motor
- 2100w heating element
- Only 73db \pm 3 at 1 metre
- Warm air output of 314.5m³/hr (185CFM)
- 7500rpm brush motor with dual ball bearings

Related items



DB 100
page 177



DBL 400
page 180



WP 174
page 24



WP 174-1
page 24



WP 194
page 39



WP 176
page 109