



Westcott 12kW Stove

UK

08/51120/0 - Issue 0

The product complies with the European Safety Standards EN13240 for Room heaters fired by solid fuel.

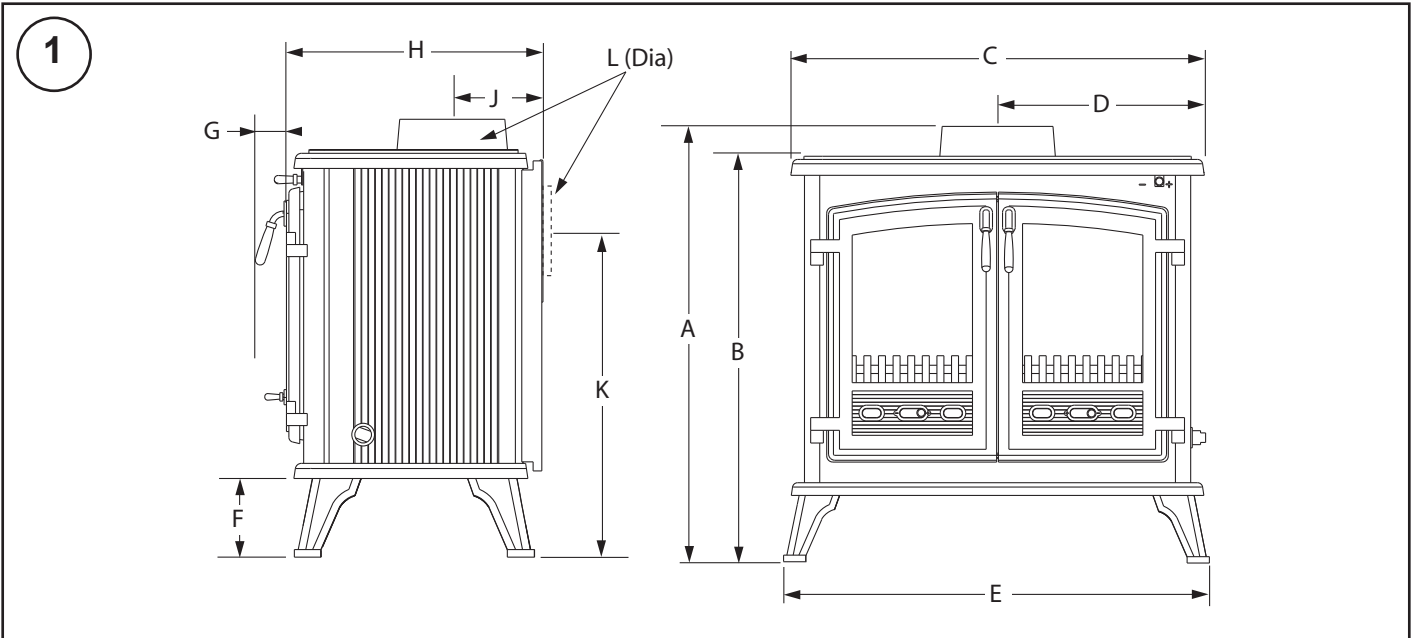
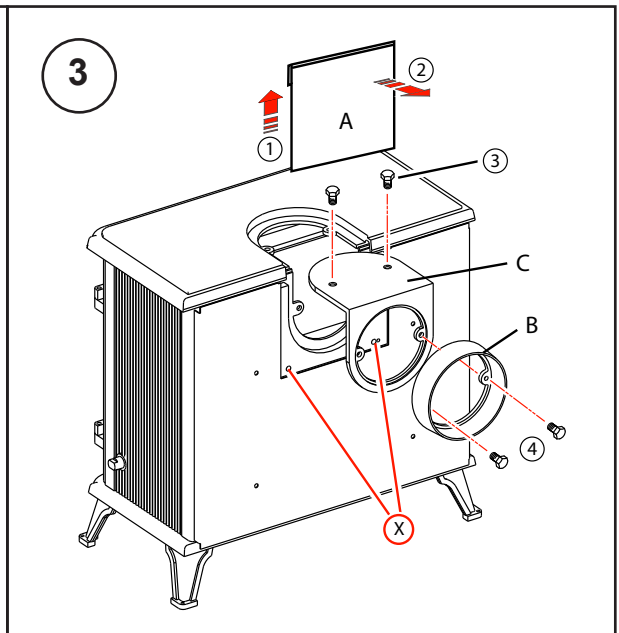
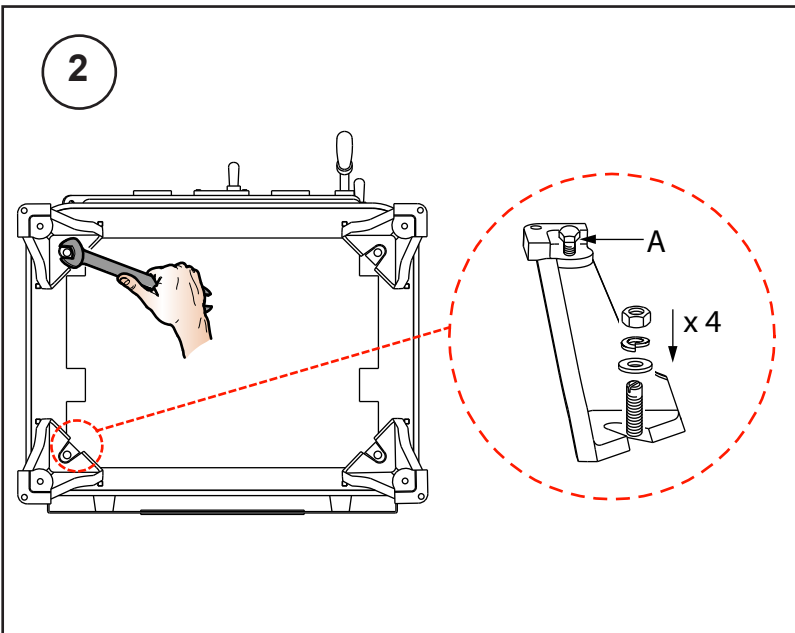

Table 1 - Dimensions	A	B	C	D	E	F	G	H	J	K	L
Westcott 12kW	688	640	652	326	670	104	50	356	113	538	150

Note: All Dimensions in mm. Dimensions stated may be subject to a slight \pm variation. (25.4mm = 1")

Table 2. - Technical Specification			Westcott 12kW
Nominal heat output	Wood	kW	12.1
	Solid Fuel (Ancit)	kW	12.2
Efficiency	Wood	%	73.1
	Solid Fuel (Ancit)	%	71.1
CO Emission (@13% O ₂)	Wood	%	0.68
	Solid Fuel (Ancit)	%	0.09
Flue Gas Temp		°C	396
Flue Gas Mass Flow	Wood	g/s	8.0
	Solid Fuel (Ancit)	g/s	10.0
Refuel Period		hr	1
Safe Distance to Combustibles	Sides	mm	600
	Rear	mm	600
Flue Outlet Size		mm	150
Product Weight		kg	134



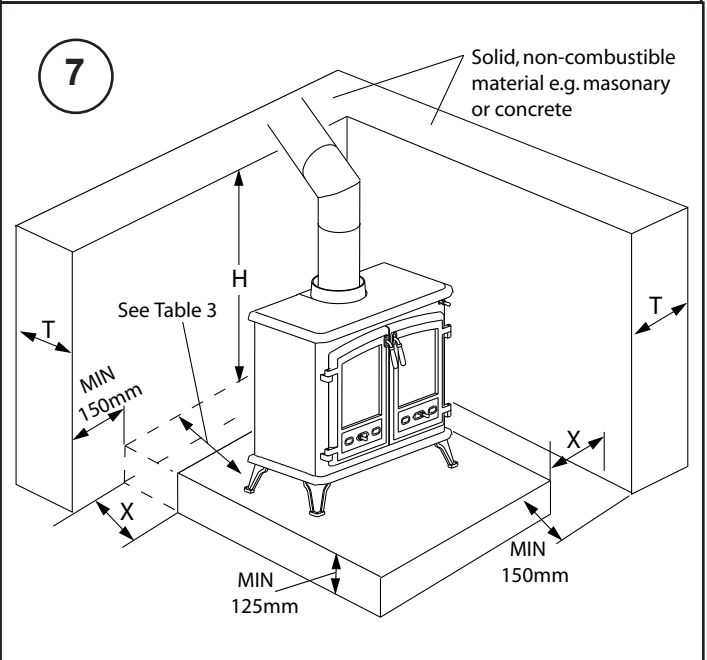
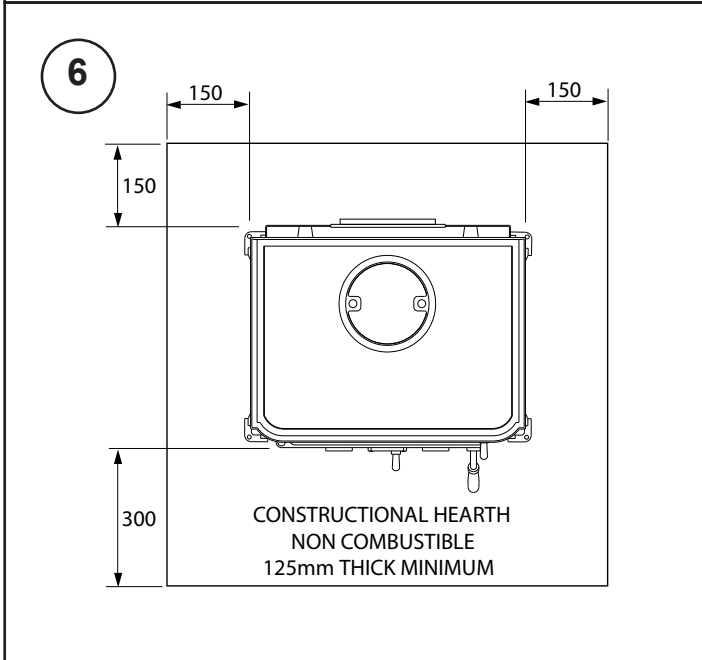
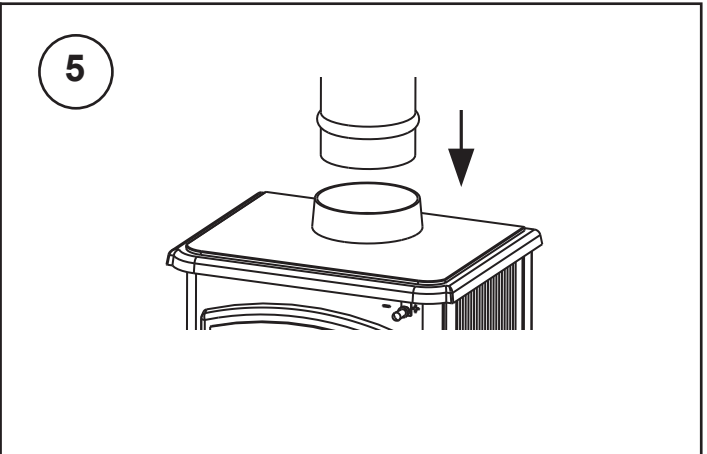
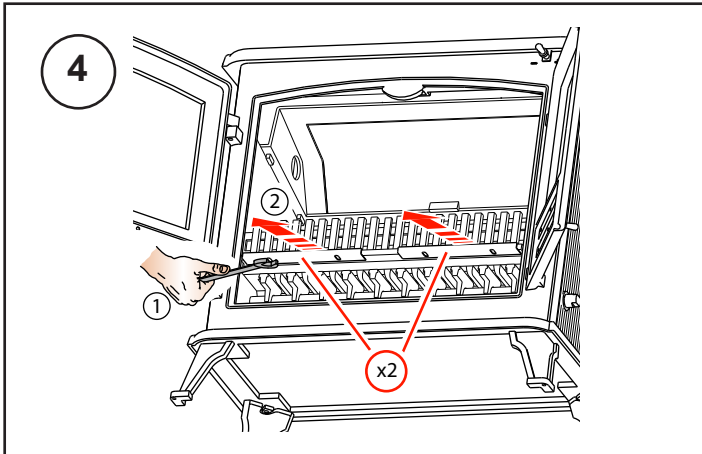
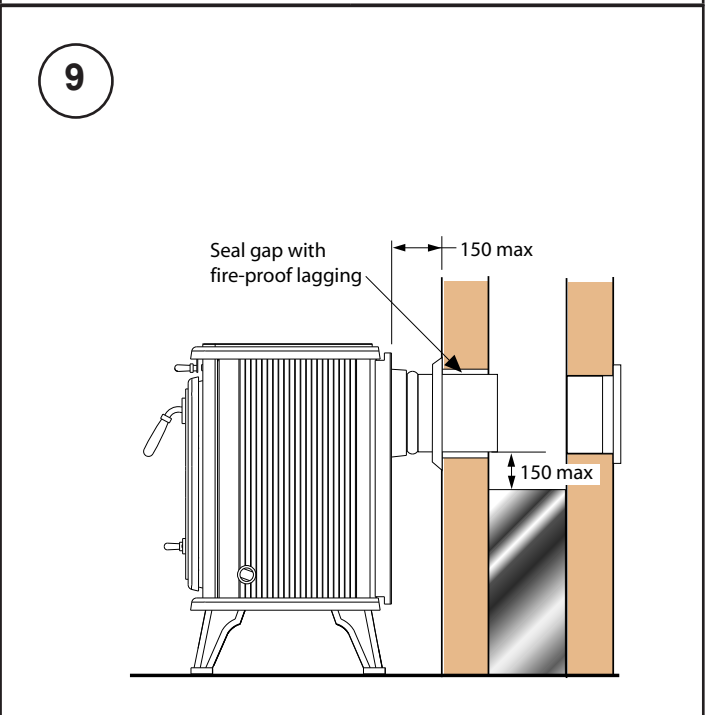
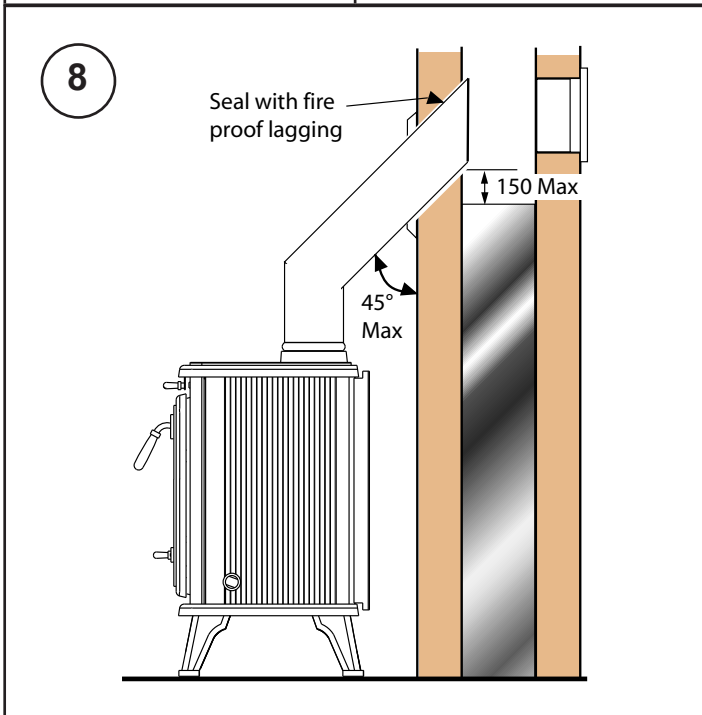

Table 3 Position of Hearth & Appliance In Relation to walls

Hearth distance from wall 'X'	Appliance distance from wall
0mm	0 - 50mm
0mm	51 - 300mm
0 - 150mm	+150mm
+150mm	+300mm

Wall Dimensions

Min Wall Thickness 'T'	Min Wall height 'H'
200mm	Height of appliance +300mm or 1200mm from hearth (whichever is greater)
75mm	
75mm	
No Minimum Requirement	



10

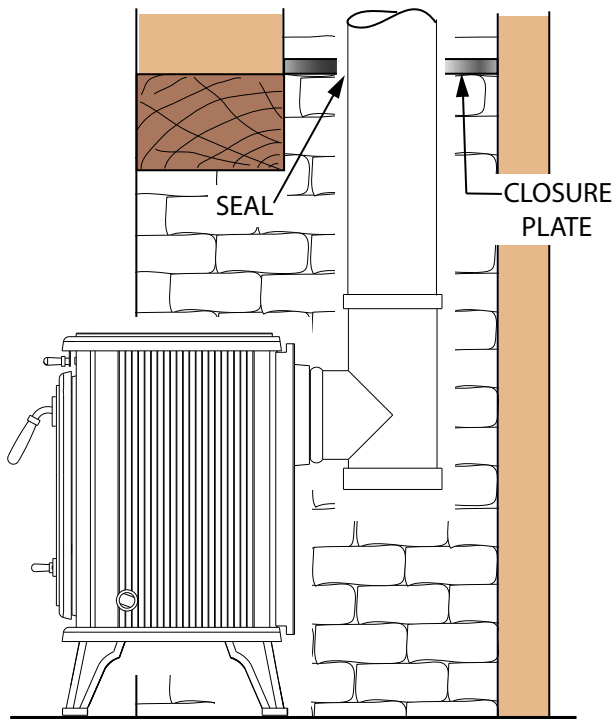

11

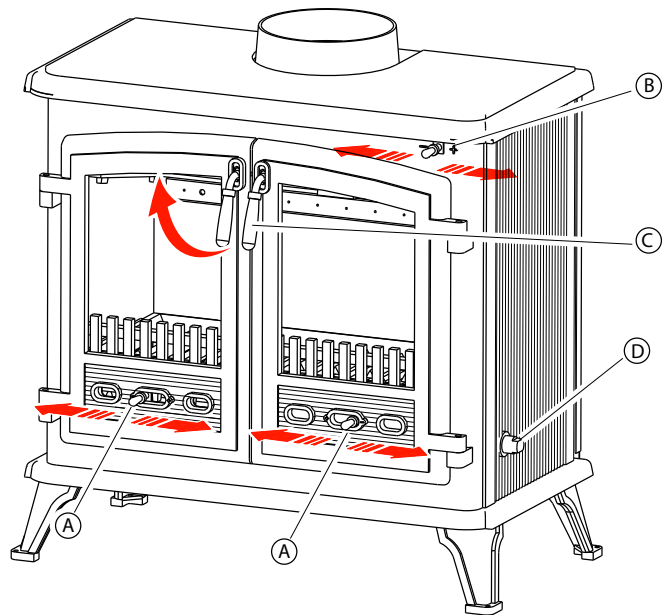

12

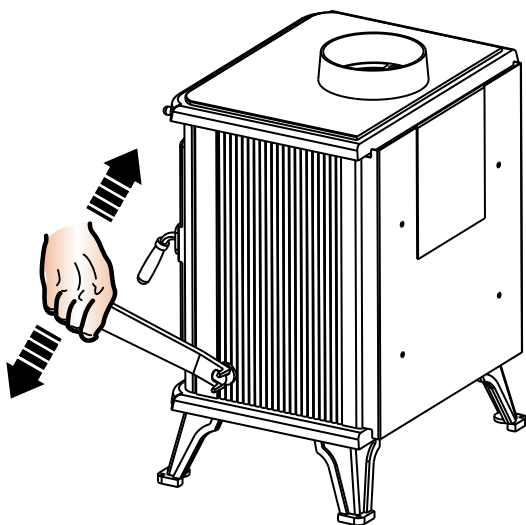

13

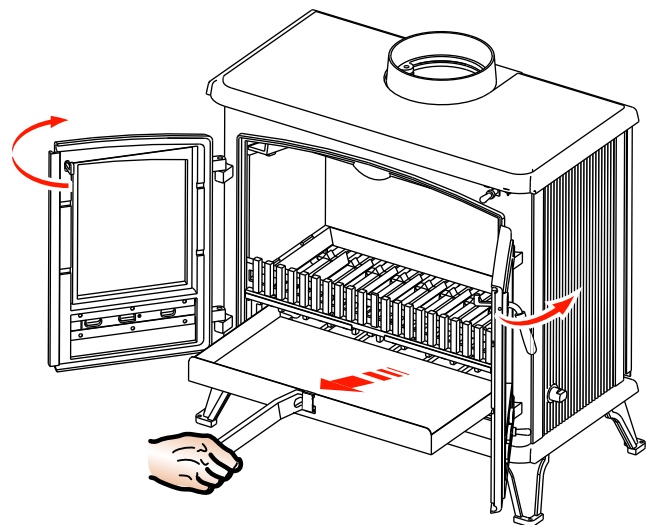

IMPORTANT: THESE INSTRUCTIONS SHOULD BE READ CAREFULLY AND RETAINED FOR FUTURE REFERENCE

Important Safety Advice

Please read these instructions carefully before installing or using this appliance. Failure to do so may result in damage to persons and property.

Installation of this appliance must be carried out by a suitably qualified competent person in accordance with all Building Regulations, including those referring to Local Authority Bye-Laws, National and European Standards and Codes of Practice.

Do not install this appliance on a shared flue.

This appliance operates at very high temperatures and retains its heat for a period after use. Do not touch any surfaces while in use. All persons including children and the infirm should be warned of this and not allowed to touch any surfaces while in use. Please use a suitable fireguard to prevent contact when in use.

Do not place any photographs, paintings, TV's or other combustible items near the appliance as exposure to hot surfaces will cause damage. Maintain safe distances from combustibles in all cases in accordance with these instructions – please refer to installation.

The operator must use the tools provided. The mitten provided is a tool.

Do not fit an extractor fan in the same room as this appliance.

Ensure that there is adequate ventilation in the room in accordance with building standards. Do not obstruct any of the air inlets or outlets on the appliance.

A flue damper should not be fitted when burning solid fuels other than wood.

This appliance is for domestic heating use only in accordance with these operating instructions. Do not make any unauthorised changes to the appliance.

Only use recommended fuels. Do not burn petroleum coke fuels, household waste or plastic in this appliance.

Burn only fuels with a low moisture content - burning soft or wet fuels such as unseasoned timber or peat will only result in a build up of tar in the stove and the chimney and will cause staining of the glass.

Do not use flammable liquids to ignite the fire.

Avoid the use of aerosols in the vicinity of the stove when it is in operation.

Clean your chimney at least twice a year and clean the flue way weekly to ensure there are no blockages. Do not allow a build up of ash to occur in the ash pan as this will cause the grate to burn out prematurely.

Regular maintenance should be carried out by a Competent Engineer.

Assembly of the stove

To make the product easier for handling on installation, remove the baffle plate, side bricks, back brick and door. Place these in a secure place to avoid damage. These must be refitted after installation.

The legs and other fixings are packed in the ashpan for safe keeping in transport. Fix the legs to the underside of the product using the bolts provided (**Fig 2**).

The stove is supplied ready for top flue connection. For Rear flue connection (**Fig 3**) remove the heat shield cover (A) and collar (B). Rotate the expanding range (C) to face in desired direction for rear flue connection and refit the collar. Tighten all fixing screws and seal with fire cement to ensure it is air tight.

The primary air sealing plate is located on the front of the grate. To locate in position, slacken the screws beneath the grate and pull forward, then close the door fully, open again and tighten the screws (**Fig 4**).

Installation Instructions

General

These instructions give a guide for the installation of the stove but in no way absolves the installer from responsibilities to conform to all relevant standards relating to the installation of solid fuel appliances.

We recommend that for UK installations a HETAS registered installer should be used, who will be able to give a Certificate of Compliance that installation complies with Building Regulations. In Ireland a registered installer from the Irish National Fireplace Organisation should be used.

Please note that to the best of our abilities these instructions are correct at time of printing, however we cannot be held responsible for any differences in legislation which may occur in the future.

Chimney

Before installing, check the chimney is in good condition; dry and free from cracks and obstructions. The diameter of the chimney flue should not be less than 150mm and not more than 230mm. If any of these requirements are not met, the chimney should be lined by a suitable method by a qualified person.

The chimney height and the position of the chimney terminal should conform to Building Regulations. If you have any doubts about the suitability of your chimney, consult your local dealer or stockist. The chimney must be swept before connection to the stove and swept every six months thereafter.

Flue Draught

The chimney should be checked before the stove is installed to ensure that there is adequate flue pull. The draught can be checked initially by using a smoke match close to the flue opening. If the chimney doesn't pull the smoke it may suggest that the chimney needs further attention.

The flue draught should also be checked under fire at high output and if it exceeds the recommended maximum a draught stabiliser must be fitted so that the rate of burning can be controlled and to prevent over firing.

Any remedial work to the chimney flue should be carried out by a suitably Qualified Engineer. A flue draught of minimum 12 Pascal is required for satisfactory appliance performance.

An extractor fan must not be used in the same room as this appliance.

Installation Clearances

The stove can be recessed in a suitable sized fireplace but a permanent free air gap of at least 150mm must be left around the sides and 300mm around the top to obtain maximum heat output and for access to the rear of the stove (Fig 6).

Table 4 shows the minimum safe distances to combustible materials that must be observed. Any surrounding combustible material should not exceed 80°C.

Table 4	Sides	Rear
Westcott 12kW	600mm	600mm

Floor Protection

In all instances the stove should be positioned on a non-combustible hearth. The construction of the hearth must conform to Building Regulations, must be firm, non-combustible and capable of supporting the stove.

Care should be taken to ensure the stove is level and the hearth is secure. The hearth itself should not be less than 125mm thick, including the thickness of the floor and any decorative top surface (e.g. tiling). Allow an apron of at least 300mm at the front of the stove in case of spills when de-ashing (Fig 6).

Place the product in the desired location on fireproof hearth taking note of installation clearances (Fig 7). Adjust the screws on the bottom of the feet to ensure the stove is level and steady (see 'A' Fig 2). The stove can be screw fixed to the floor when placed in the desired position, using the holes provided in the feet.

Flue Pipes

The flue pipe used to connect to the stove should be made of cast iron, 316 grade stainless steel or vitreous enamelled steel, nominal thickness 1.2mm. The diameter of the flue pipe should be 150mm (6") for the Westcott 12kW model.

Connect the flue pipe to the stove making sure that it fits snugly into the base of the flue collar (Fig 5). Seal the collar and flue connection with fire cement or with other suitable high temperature sealant. Add flue sections as required; note that all flue sockets must face upwards. Ensure that the flue pipe end is no closer than 76mm to the side or rear of the chimney walls. It is essential that all connections between the stove and the chimney flue are sealed and made airtight.

Avoid using bends greater than 45° to the vertical (Fig 8). All flue pipes should be as close to vertical where possible. For rear flue connection the length of the horizontal run of the flue pipe should not exceed 150mm (Fig 9).

Both chimney and flue pipe must be accessible for cleaning and if ALL parts of the chimney cannot be reached, a soot door must be fitted to enable this to be done.

This product should not be installed on a shared flue.

Existing Fireplace

An existing fireplace opening can be bricked up or sealed with a register plate, 2.5mm sheet steel or concrete. A short length of flue pipe may then be used to connect the stove to the chimney. Ideally the old fireplace should be filled in so that there is a smooth streamlined entry into the flueway. (Fig 9)

Typical installation for Inglenook Fireplaces

Inglenook fireplaces can have very large bore chimneys (Fig 10). Check with your installer – you may need a stainless steel flexible flue liner for solid fuel fitting.

Flue Damper (Not Supplied)

When burning wood, a flue damper may be fitted to reduce the draught through the stove if the draught is too high. When the damper is set in the open position the chimney draws at full draught, increasing the volume of air flow through the stove and flue. Shutting the damper restricts the flow, slowing the rate of burning.

The damper should be fitted to the stove flue and should be the same size as the flue pipe. As a rule it should be fitted no closer than 700mm from the flue outlet of the appliance.

A flue damper should not be fitted when burning solid fuels other than wood.

Flue Deposits

If the chimney was previously used as an open fire, it is possible that the higher flue gas temperatures generated by the stove may loosen deposits that were adhering to the inner surface of the flue pipe and may cause blockage of the flue pipe. We recommend that in such a situation a second sweeping of the chimney should be carried out within one month of initial stove use after installation. Also lock or close off any existing dampers in the flueway.

Commissioning

Upon completion of installation, the stove and flue system should be tested by a suitably qualified person to make sure it is safe for normal use. A smoke draw test should be completed to check for soundness of joints and seals and also that all smoke and fumes are taken from the appliance up the chimney and emitted safely.

First warm the flue with a blowlamp or similar for about 10 minutes. Place a lit smoke pellet on the centre of the grate with the air controls open. Close the door – the smoke should be drawn up the flue and be seen to exit from the flue terminal. Complete the test with all windows and doors shut in the room where the appliance is fitted. If a ceiling fan is present it must be operated on max for the duration of the test. If there are any extraction fans in adjacent rooms these too must be operated on maximum setting during the test with the interconnecting doors open. If any spillage occurs, recheck the suitability of the flue system making sure there is adequate air supply to the room (as per Building Regulations).

Light the appliance and slowly increase the temperature to operating levels. Open the main fire door when the appliance reaches normal operating condition and carry out a spillage test using a smoke match or pellet around the door opening. If any spillage occurs, open all windows, allow the fire to go out and recheck the flue system and ventilation.

Operating Instructions

Warning: The door and operating handles become hot when the stove is in use. For your safety use the glove provided.

Initial Firing of Stove

We recommend that you have two to three small fires before you operate your stove to maximum heat output. This is to allow the paint to cure and the castings to relax and consolidate location. We recommend this 'running in' procedure after long idle periods to preserve the life of the stove. During this you may notice an unpleasant smell. It is not toxic but for your own sake we would suggest that during this period you leave all doors and windows open.

Air Controls

Primary air is controlled via the sliding vents (**A - Fig 11**) in the bottom of the door; this provides a conventional air draught to the bed of the fire. (+) indicates more air, (-) indicates less air, (+) and (-) are marked on the primary and secondary air controls.

Secondary air is controlled via the sliding vent (**B - Fig 11**) above the door. It is this 'Airwash' that keeps a clean and uninterrupted view of the fire, also aiding in good secondary combustion of fuel and reducing emissions into the chimney and environment.

The Westcott 12kW is fitted with a tertiary (third) air inlet system. Air is bled into the stove from the rear panel via an air duct over the rear brick. Its function is to ignite unburned gasses and assist clean burning. It is advisable to clear the holes in the duct occasionally when the stove is being serviced or after long periods of burning (dirty) fuel, i.e. bitumas coal. For safety this should only be done when the stove is cold.

The tertiary air supply is permanently open and only allows a small fixed amount of air into the stove. However if you suffer from poor flue draft or regularly use smokeless fuel (e.g. Anthracite) it may be beneficial to close off the tertiary air supply. To close tertiary air, wait until stove is cool, remove the heat shield cover (**A - Fig 3**), fit the screw plugs supplied into 2 holes on rear of stove (**X - Fig 3**) and replace heat shield cover.

Lighting the Stove

Place fire lighters or paper and kindling on the grate. Light the fire at base leaving all air controls open. Allow the fuel to reach a steady glow and build the fire up gradually. Once you have a good fire established across the grate bed, further fuel can be added as required.

Running the Stove

When your fuel is well alight you can start to restrict the primary air intake. If you are only burning wood the primary air control can be fully closed. If you are burning solid fuel you will require more primary air. Your stove is burning with maximum efficiency when a bright fire is achieved using minimum air inlet.

The stove can be banked up for long periods. When burning solid fuel empty the ash pan. Open air controls and let the fire burn brightly for a short period. Refuel and close air controls; the exact setting required will depend on the fuel used and the chimney draw so some practice may be necessary. To revive the fire, open air controls until the fire is burning brightly, de-ash if necessary and refuel. Set air controls as required. The stove is not suitable for overnight burning.

Notes on Wood Burning

Wood burns best on a bed of ash and it is therefore only necessary to remove surplus ash from the grate occasionally. Burn only

dry, well seasoned wood, which should have been cut, split and stacked for 12 months with free air movement around all sides of the stack to enable it to dry out. Burning wet or unseasoned wood will create tar deposits in the stove and chimney and will not produce a satisfactory heat output. When loading wood, make sure that the end grain of the wood in the stove is pointing away from the glass otherwise the moisture and gases coming from the end grain of the wood will dirty the glass.

Table 5 - Maximum log lengths

Westcott 12kW	500mm (19 ½")
---------------	---------------

Notes on Solid Fuel burning (Other than Wood)

Always de-ash the grate before refuelling and do not let the ash build up to the underside of the grate bars. Solid fuel produces ash, which if allowed to build up will stifle the air flow through the grate and will eventually cause the fire to die. It is important it is to empty the ash pan after each firing of the stove. Air passing through the firebed cools the grate. Distortion or burning out of the grate bars is nearly always caused by ash being allowed to build up on the underside of the grate. With some solid fuels a residue of burnt fuel or clinker will accumulate on the grate. Allow the fire to go out periodically to remove this.

We recommend the majority of approved manufactured smokeless fuels. Note that different types of fuel will give different performances. Use as an incinerator for household waste is not recommended as fumes from plastic, etc will cause pollution to the atmosphere and will cause damage to the stove. Should any difficulties arise over fuel quality or suitability, consult your local supplier or contact the Solid Fuel Advisory Service.

Petroleum coke fuels or household waste should not be burned on this appliance.

De-Ashing

To de-ash the grate insert the notch on the riddle hand tool into the peg on the side of the stove (**D - Fig 11**), then draw the tool forwards and backwards with a slow positive action (**Fig 12**).

The ash pan should be emptied each time after operating the stove so not to let build up of ash occur. Where possible, it is best to wait until the stove and ash has cooled before removing the ash pan. To remove, open the stove door by lifting the handle upward (**C - Fig 11**) then using the riddle handle lift the ash pan out of the fire (**Fig 13**). For efficient burning of your appliance, make sure the grate is clear of burnt debris; e.g. nails, etc.

Shut down Periods

If shutting down the stove for long periods (e.g. for summer months) make sure that all ash is removed from the stove and that the chimney flue ways and baffle plate are brushed clean. When the stove is cold a vacuum cleaner may be used to remove any residual ash or soot. Close the door and leave all air inlets open fully. This action will ensure air circulation through the appliance and will help to avoid corrosion and condensation within the appliance during this shut down period.

Safety Notes for Your Guidance

FIRES CAN BE DANGEROUS.

Always use a fire guard in the presence of children, the elderly or the infirm. Inform all persons the dangers of high temperatures during operation of the appliance including the stove pipe.

Use operating tools provided.

DO NOT OVER FIRE.

It is possible to fire the stove beyond its design capacity. This could damage the stove, so watch for signs of over firing. If any part of the stove starts to glow red, the stove is in an over fire situation and the controls should be adjusted accordingly to reduce air intake. Never leave the stove unattended for long periods without adjusting the controls to a safe setting. Careful air supply control should be exercised at all times.

Warning - Fume Emissions

Properly installed and operated, this appliance will not emit fumes. Occasional fumes from de-ashing and refuelling may occur. Persistent fume emission must not be tolerated. If fume emission does persist, then the following immediate action must be taken:

1. Open doors and windows to ventilate the room.
2. Let the fire out, or eject and safely dispose of fuel from the appliance.
3. When the stove has cooled, check for chimney flue blockage and clean if required.

Do not attempt to relight the fire until the cause has been identified. If necessary seek professional advice.

General Maintenance

Baffle Plate: This should be removed at least once a month to prevent any build up of soot or ash, which could lead to blocked flue ways and dangerous fume emission. If the baffle plate is removed the chimney/flueway can be swept through the appliance.

Stove Body: The stove is finished with a heat resistant paint and this can be cleaned with a soft brush. Do not clean while the stove is hot, wait until it has cooled down. The finish can be renovated with a suitable brand of paint.

Glass Panels: Clean the glass panels when cool with a proprietary glass cleaner. Highly abrasive substances should be avoided as these can scratch the glass and make subsequent cleaning more difficult. Wet logs on heated glass, a badly aimed poker or heavy slamming of the doors could crack the glass panels. The glass will not fracture from heat.

Chimney: Check your chimney each year before starting to use your stove for the winter. Birds may have nested in the chimney or masonry may have cracked. Both chimney and flue pipe must be swept at least once a year by a Qualified Chimney Sweep.

To avoid a build up of soot on the baffle plate (the plate inside the stove above the grate) it must be removed and cleaned periodically. This plate locates the back and side firebricks so note its position before removal. To remove, lift plate and remove one side brick; this will allow the plate to drop and aid removal. To replace, position baffle plate on back and side plate, lift plate and replace remaining brick, making sure it has located in position. This must be done when the stove is cold.

Troubleshooting**1. Poor heat output**

- a. Stove too small for room: Seek advice from a Qualified Heating Engineer as to (kW) output required for the room size. As a guideline the volume of the room in cubic feet divided by 500; e.g. room 15'x15'x8' would require 3.6kW approx.
- b. Chimney and/or flue pipe restricted, room ventilation restricted: On installation these should have been checked but regular maintenance is necessary as conditions can change; e.g. soot

build up, birds nesting, masonry fall, dust build up or furniture blocking vents.

- c. Poor quality fuel: Only burn dry seasoned timber, soft woods have a lower heat output than hard woods per hour. Solid fuels vary in heat value; check with your coal merchant as to suitability.

2. Dirty Glass Panel

- a. Generally caused by poor fuel quality, see (1c)
- b. Use secondary air slide (Airwash) for glass panel
- c. Fire burning too low, open air vents on stove to create hot fire; this may 'burn' glass clean.
- d. If glass requires cleaning use glass cleaner recommended by your supplier; only use glass cleaner on cold glass. DO NOT USE any abrasives or scrapers as these will scratch glass and increase future tar build up making it harder to clean.

3. Unburnt Fuel in Firebox

Insufficient air reaching fuel. Open primary air slide, this will supply combustion air to burn fuel fully (unless it has reached a 'point of return'). Check if the ash pan is full and empty if required. De-ash with the riddler to make sure the grate is not blocked and check for jammed clinker or nails when the fire is out and the stove has cooled.

4. Smoke and Fumes Entering Room

These are very dangerous and must NOT be tolerated. Open window and allow fire to burn out. Seek expert advice immediately. DO NOT USE stove until the problem is solved.

5. Chimney Fire

Identified by loud roaring sounds, dense smoke and sparks emitting from chimney. Shut down the air supply by closing air vents, close stove door fully and call fire brigade immediately. Regular chimney maintenance will prevent chimney fires. Seek advice from a Qualified Chimney Sweep. Chimneys must be checked annually and more often when bitumas coal and poor quality smokey fuels are used.

After Sales Service

Your Dimplex Stove is guaranteed against defects arising from faulty manufacture for 1 year subject to the following conditions. Failure to comply with these conditions will invalidate the guarantee:

- The receipt must be kept as proof of purchase.
- Your Dimplex stove must be installed by suitably qualified individual (HETAS Engineer or equivalent) and upon installation a Certificate of Compliance must be presented.
- The guarantee is 1 year from date of purchase.
- The guarantee does not cover parts that are deemed to be replaceable through normal usage of the stove. These include: glass panels, rope seals, bottom grate or firebars, ashpan, firebricks, cast iron liners, riddling lever, baffle plate, log guard.
- Only genuine Dimplex spare parts should be used. Parts that may need occasional replacement are: firebricks, ashpan, fire grate, log guard.

Should you require after sales service or should you need to purchase any spares, please contact the retailer from whom the appliance was purchased. Please do not return a faulty product to us in the first instance as this may result in loss or damage and delay in providing you with a satisfactory service. Please retain your receipt as proof of purchase.

WESTCOTT 12KW

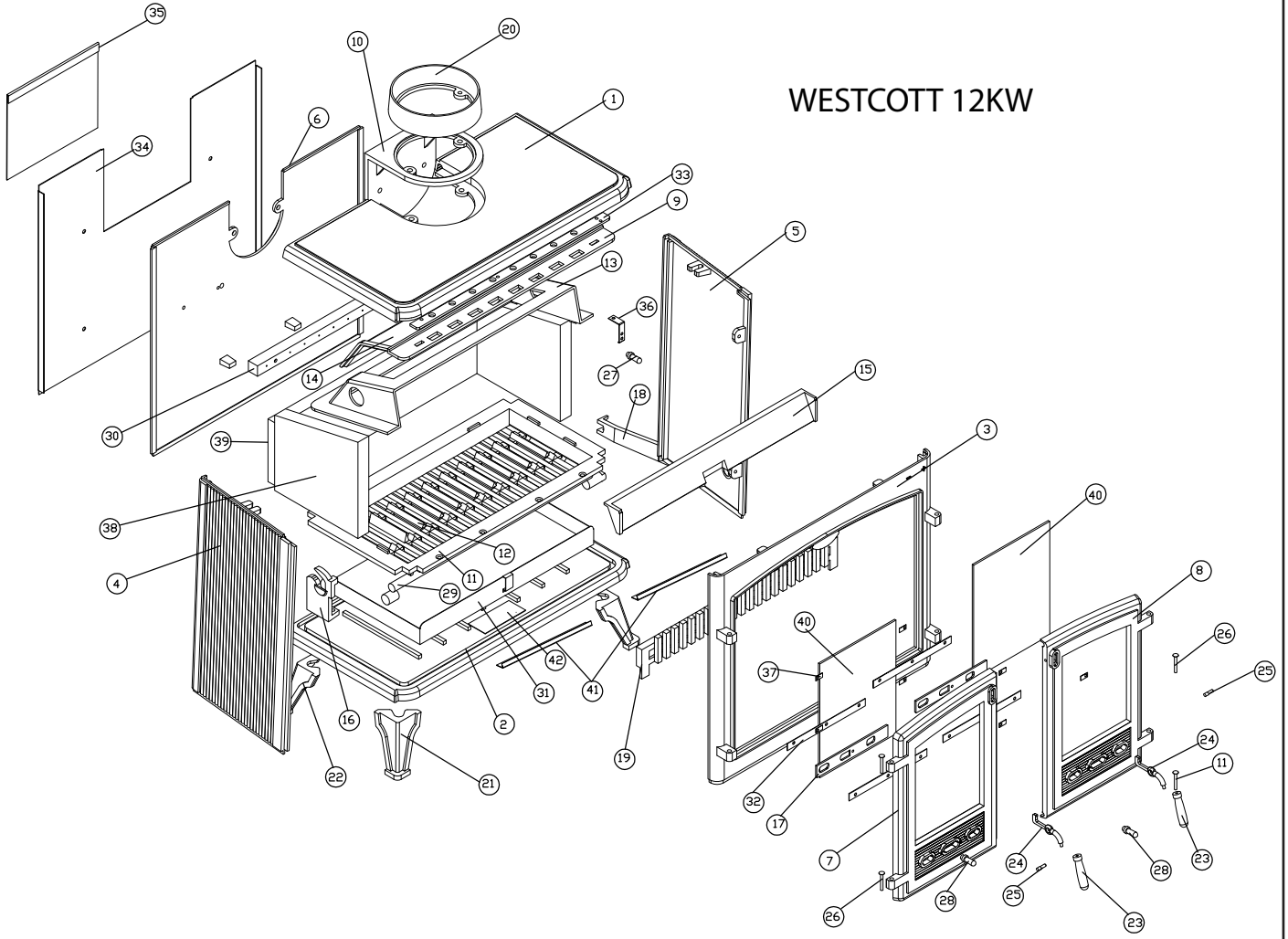

Item	Description	Part No	Qty
1	Top	D380001	1
2	Base	D380002	1
3	Front Panel	D380003	1
4	LH Side Panel	D380004	1
5	RH Side Panel	D380005	1
6	Back	D380006	1
7	LH Door	D380007	1
8	RH Door	D380008	1
9	Secondary Air Shaft	D190007	1
10	Expanding Range	D190008	1
11	Grate Outer	D190009	1
12	Grate Inner Bars	D190010	10
13	Baffle Plate Frame	D190011	1
14	Baffle Plate	D190012	1
15	Air Wash Deflector Plate	D190013	1
16	Supporting Bracket	D190014	1
17	Primary Air Slide	D190027	2
18	Grate/Ashpan Operating tool	D360009	1
19	Front Bar	D380009	1
20	Flue Collar	D190016	1
21	Front Legs	D360010	2
22	Back Legs	D360011	2

Item	Description	Part No	Qty
23	Door Handle (2x nickel, 2x black)	D360017	4
24	Door Handle Shaft	D360018	2
25	Door Handle Shaft Pin	D360019	2
26	Hinge Pin	D110023	4
27	Secondary Air Knob (1x nickel, 1x black)	D360015	2
28	Primary Air Knob (2x nickel, 2x black)	D360016	4
29	Grate Riddler	D190018	1
30	Air Duct	D190019	1
31	Ash Pan	D190020	1
32	Air Slide Guide Plate	D380010	4
33	Secondary Air Slide	D190022	1
34	Heat Shield	D190023	1
35	Heat Shield Cover	D190024	1
36	Secondary Air Knob Bracket	D110021	1
37	Glass Clip	D110022	8
38	Side Brick	D1900025-A	2
39	Back Brick	D1900025-B	1
40	door Glass	D380011	2
41	Grate Connector	D380012	2
42	Data Plate	D380024	1

Dimplex
Millbrook House
Grange Drive
Hedge End
Southampton
Hampshire. SO30 2DF

www.dimplex.co.uk

Republic of Ireland Tel. 01 8424833

[c]A Division of GDC Group Ltd.

All rights reserved. Material contained in this publication may not be reproduced in whole or in part, without prior permission in writing of GDC.