

ITEM	DESCRIPTION
1	CASE
2	WIRING PLATE
3	GRILLE & FRAME
4	FAN
5	3 KW ELEMENT
6	MOTOR ASSEMBLY
7	FRONT PANEL
8	REFLECTOR
9	OVERHEAT CUTOUT <small>FITTED TO FRONT PANEL</small>

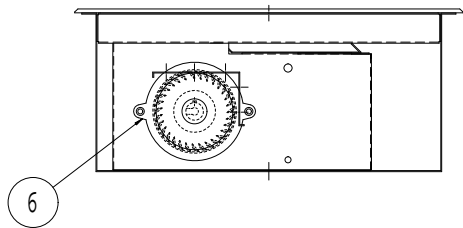
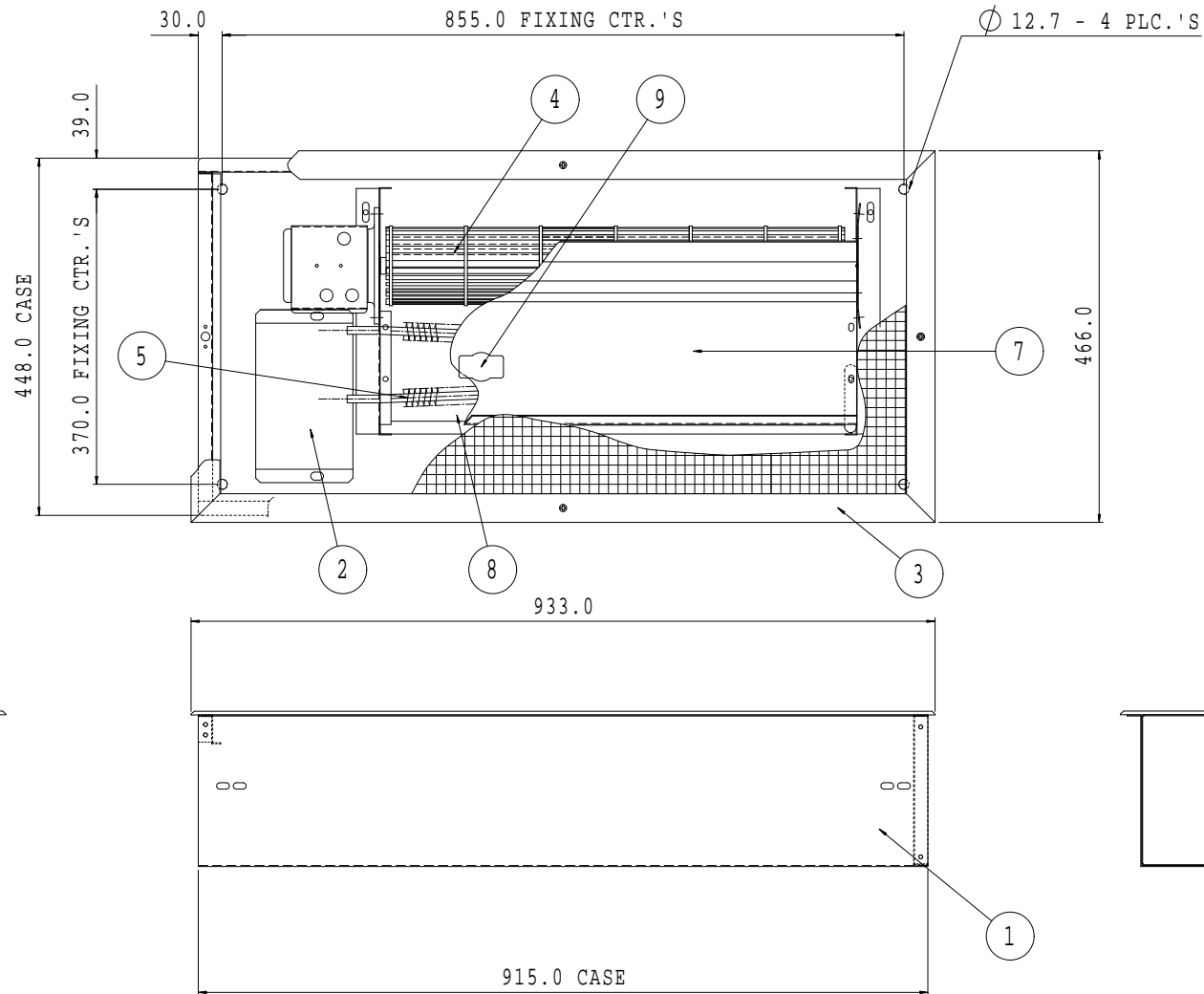

NOTES:
1: ALL DIMNS TO OUTSIDE OF EDGE OF MATERIAL, UNLESS STATED OTHERWISE.

REV.	MOD.NO.	DATE	DRN	CHKD	DRAWING TO B.S. 308:PARTS 1,2 AND 3. WELDING TERMS AND SYMBOLS TO B.S. 499:PART 2.	SCALE : NTS	DRAWN ANR	DIFFUSION ENVIRONMENTAL LTD 47 Central Avenue, West Molesey, Surrey, KT8 2QZ Telephone 020-8783-0033. Fax 020-8783-0140
3	R-RADAN	01-05-01	ANR				DATE 01-05-01	
2	ECR 1343	26-10-95	GC				CHECKED	TITLE SALES GA TRE / 09 3KW
1	ECR 1084	15-07-93	RP				DATE	
A	ECR 410	15-07-91	SSC				APP'D	JOB STANDARD
						FINISH :	DATE	DRG.NO. A1/105 000

GEOMETRIC TOLERANCE SYMBOLS		ALL DIMENSIONS IN MM THIRD ANGLE PROJECTION	
CHARACTERISTIC	SYM	CHARACTERISTIC	SYM
Straightness	—	Angularity	∠
Flatness	▭	Run out	↗
Roundness	○	Position	⊕
Cylindricity	⊘	Concentricity	⊙
Profile of a line	⌒	Symmetry	⊞
Profile of a surface	⌒	M.M.C.	⊖
Parallelism	//	Squareness	⊥