

PRESSURE REDUCING VALVE TYPE WRP2

PLASTIC CONSTRUCTION

DESCRIPTION

The Dereve Pressure Reducing Valve type WRP2 has been developed for low flow situations and is suitable for WATER and AIR duties.

WATER: capacity up to 10 L/min (2.2 gal/min)

AIR: capacity up to 150 L/min (5.3 cfm)

Variable and fixed outlet pressure versions are available. In the variable versions, setting of the outlet pressure is obtained by an adjusting screw located beneath the push-on plastic cap and engaged by a screwdriver. The outlet pressure is increased by turning the screw anti-clockwise.

The body and cover are manufactured from acetal, the diaphragm 'O' ring, valve pad from synthetic rubber and other internal parts from nylon and brass.

When the outlet flow of the WRP is reduced to zero the valve 'locks up' i.e. does not allow the outlet pressure to rise appreciably above the set outlet pressure.

The method of connection enables variation of size/type to be achieved without changing the body of the reducing valve. Although the body is plastic, the method gives electrical continuity across the valve.

Connectors available

1/4" BSP (External or Internal) formed to accept compression fittings.

1/2" BSP (External or Internal) formed to accept compression fittings.

Other connectors can be supplied on request including hose or plain stubs.



OPERATION

The inlet pressure acts upwards on the valve washer and downwards on the other end of the valve spindle which is sealed by an 'O' ring. As these areas are almost equal a balance of forces is produced. The pressure below the diaphragm is atmospheric and is maintained by a breather hole (6) in the cap. The diaphragm (5) is loaded by the spring (2) and adjuster spring (1) which engages valve (3) with resilient washer (4).

The outlet pressure acting over the effective area of the diaphragm opposes the spring force to produce equilibrium. Changes of flow and inlet pressure are compensated for by the control so that near constant outlet pressure is maintained.

In the fixed reducer version the adjuster spindle and nut are removed and the diaphragm loaded with one spring (2) only.

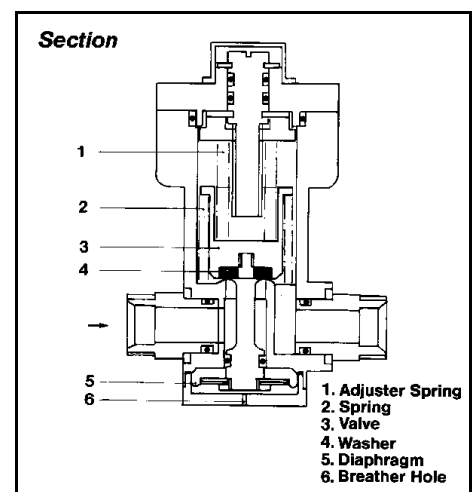

BONUT ENGINEERING LTD

Unit 12, Latham Close • Bredbury Industrial Park • STOCKPORT SK6 2SD

Tel: +44 (0) 161 430 4000 Fax: +44 (0) 161 494 1461

Email: info@bonutengineering.co.uk website: www.bonutengineering.co.uk

PRESSURE REDUCING VALVE TYPE WRP2

Performance

Water

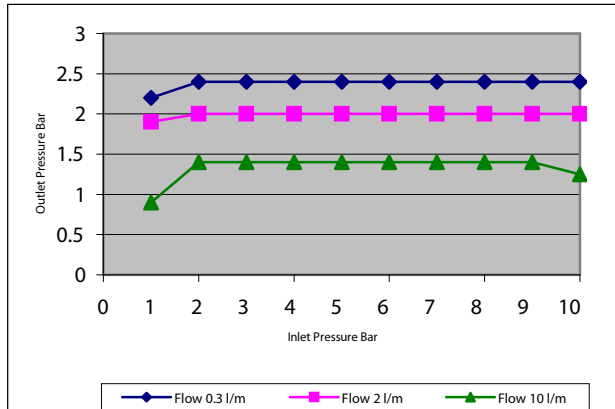

Air

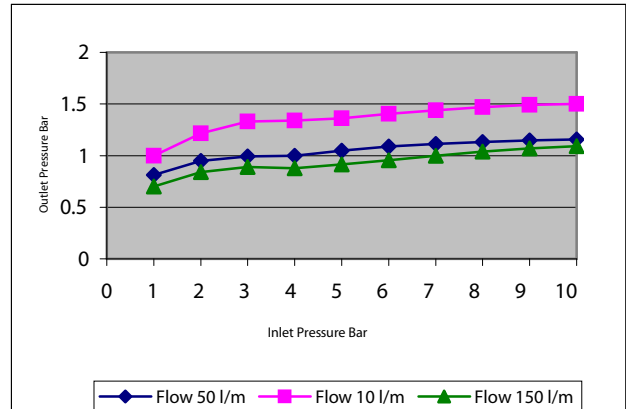

Technical data

Type	WRP2
Connection Range	1/4" BSP—1/2" BSP
Flow Range Water - L/min (gal/min)	0-10 (0-2.2)
Flow Range Air - L/min (cfm)	0-150 (0-5.3)
Max. Inlet Pressure - barg (psig)	10 (150)
Outlet Pressure Range - barg (psig)	0.2-4.0 (2-60)
Maximum Working Temperature - deg C (deg F)	60 (140)
Weight - gms (lb)	255 (0.56)

Selection table

	Product no.	Outlet Pressure Range
WRP2 Adjustable	07100/08	0.2 - 2.0 barg (2-30 psig)
WRP2 Adjustable	07100/09	2.0 - 4.0 barg (30-60 psig)

Valves can be supplied with fixed pressure settings within the above range

Installation

The Dereve Pressure Reducing Valve can be mounted in any position and the direction of flow is marked with an arrow.

All pipes must be free of burrs and should be clean before being connected.

The housing of the control must not be used as a lever and undue force must not be applied to assembly connections.

If compression fittings have been supplied with the control, screw in the nut finger tight plus one turn.

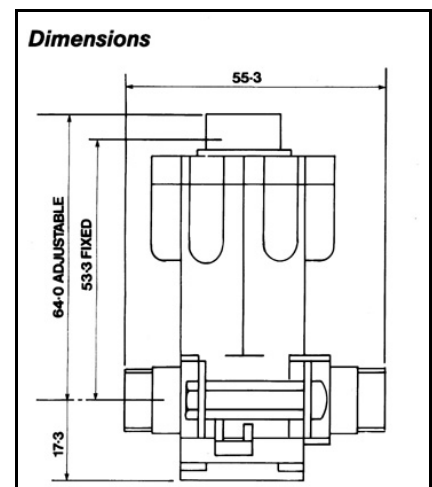

BONUT ENGINEERING LTD

Unit 12, Latham Close • Bredbury Industrial Park • STOCKPORT SK6 2SD

Tel: +44 (0) 161 430 4000 Fax: +44 (0) 161 494 1461

Email: info@bonutengineering.co.uk website: www.bonutengineering.co.uk