

SINGLE SUMP V3 & SINGLE SUMP WITH INLETS

Installation Instructions and Technical Details



o Application

The Single Sump V3 is designed to evacuate water collected from the Delta cavity membrane system installed in basement applications.

The Single Sump is designed to protect against future water ingress to comply with BS8102, if the basement is wet or has running water the Dual V3 Sumps should be used

Ground water in basement applications is collected via the cavity membrane system through the clear opening at the top of the chamber.

o Method of operation

The Single sump chamber is manufactured from high-density polyethylene and is designed to resist ground water pressure and is fitted with one powerful PPS V3 pump.

The sump chamber is fitted with one brass non-return valve to prevent water travelling back into the chamber once the pump has stopped.

o Maintenance

The Single sump chamber is manufactured using high quality components designed to give a long a trouble free life. With any piece of mechanical equipment regular preventative maintenance is important to keep this product working efficiently on a day-to-day basis. We recommend the sump is serviced twice / year by specialist pump engineers.

o Service

For service you may contact PPS (Packaged Pump Systems) who can service this equipment.

Telephone 01279 757400.

SINGLE SUMP AND SINGLE SUMP WITH INLETS

Inlets, cable ducts and discharge pipe work

Inlet pipe work (single sump with inlets only)

The Single Sump with Inlets accepts standard 110mm underground drainage pipe. Through tank connectors are pre installed on the chamber, therefore no additional adaptors are required

Discharge pipe work.

The Single Sump chamber has been designed to accept the following pipe work types;

1¼" standard solvent weld drainage pipe (use male iron adaptor supplied).

Heliflex reinforced flexible pipe work (hose tail and jubilee clip required - not supplied).

1¼" PVC-U class C solvent welded pressure discharge pipe.

DO NOT USE PUSH FIT FITTINGS

Cable duct pipe work.

The Single Sump chamber has been designed to accept the following pipe work type:

1¼" standard solvent weld drainage pipe

Electrical connections

The pump and high level alarm are to be electrically connected to a non switched fused spur (total of two). This spur should have its own dedicated supply from the main fuse board.

It is advisable to leave 500mm of the pump electrical cable in the sump to allow for servicing of the pump outside the sump.

Pumps must not be wired to a 'RCD' or similar protective device.

Float

Ensure float does not foul chamber sides. It may be necessary to rotate pipe work on pump to achieve this as there may have been some movement during transit.

INSTALLATION INSTRUCTIONS

It is important to note these instructions are for guidance only and it is the contractor's responsibility to satisfy himself that the installation procedure is in accordance with the prevailing ground conditions and good building practice, to eliminate any potential damage to the pump station either during or after installation.

Delta pump stations are manufactured from high density polyethylene and are extremely robust. However as with any preformed pump chamber they are susceptible to floatation and hydrostatic pressures exerted in high water table conditions.

1. Select a suitable location for the pump station.
2. In all instances the pump station must be positioned on a flat, level surface, set on concrete base of dimensions sufficient to support the base of the chamber. The thickness of the base should be adequate for the ground conditions and of minimum 150mm thick.
3. Carefully position the pump chamber onto the base slab ensuring that no loose debris is inadvertently knocked onto the base slab, under the pump station during this procedure.

4. The pump station must be back filled with a mass concrete mix of minimum 150mm thickness and must be used in accordance with the ground conditions and be as dry as practical to prevent additional flotation pressures being exerted on the chamber.

The pump chamber MUST be ballasted with water at the same rate as backfilling such that the level difference between the water and backfill does not exceed 300mm at any time.

5. Where ground water is present in the excavation, de-watering must be undertaken throughout the installation procedure and until

the backfill has completely cured.

6. Similarly, the ballast water inside the pump station should not be removed until the backfill has fully cured.

7. It is extremely important that once the pump station has been installed and all connections made, the drainage system is flushed through and all sand, silt, rubble and general debris removed from the pump chamber. **FAILURE TO DO THIS WILL INVALIDATE THE WARRANTY ON THE PUMPS.**

8. The alarm panel housing (if applicable) must be sited adjacent to the pump station with 50mm cable ducts (with draw cords) for the cabling. If the control panel is not to be sited adjacent to the pump station Delta should be advised at order stage so that we can make recommendation as to the cabling required.

ALL ELECTRICAL CONNECTIONS MUST BE CARRIED OUT BY A QUALIFIED ELECTRICIAN.

PPS PUMP - V3 pump TECHNICAL DETAILS

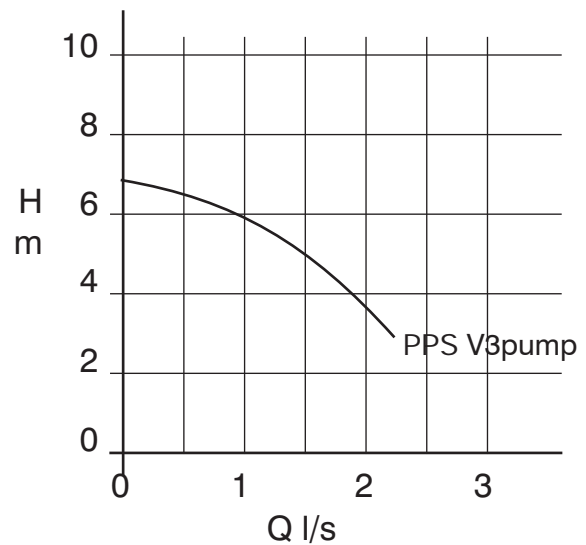

Performance tolerance to ISO 2548, Class C (water under normal conditions)

ISO 7/1 Rp	1¼"
Particle size	10mm Max.
P1	0.3 kW
P2	0.15 kW
50Hz 1-230 V	1.4 A
Power supply cable H 07 RN-F.G.	5m 3 x 0.75
Weight (Pump)	3.9kg net

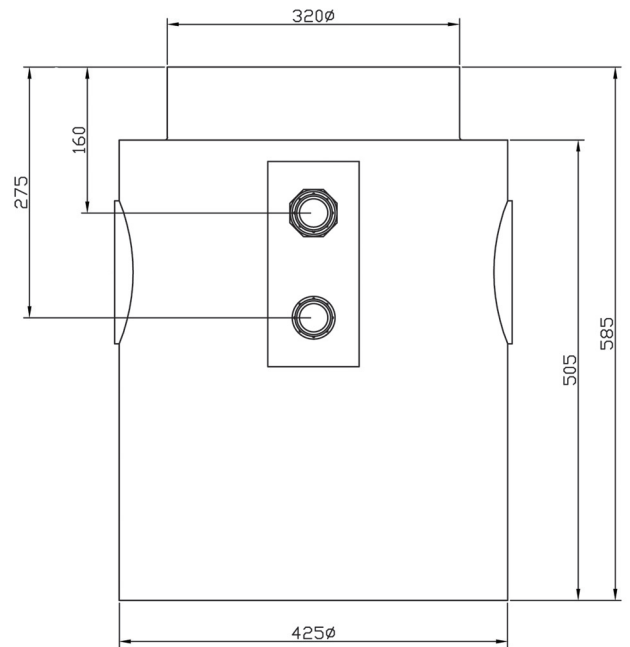
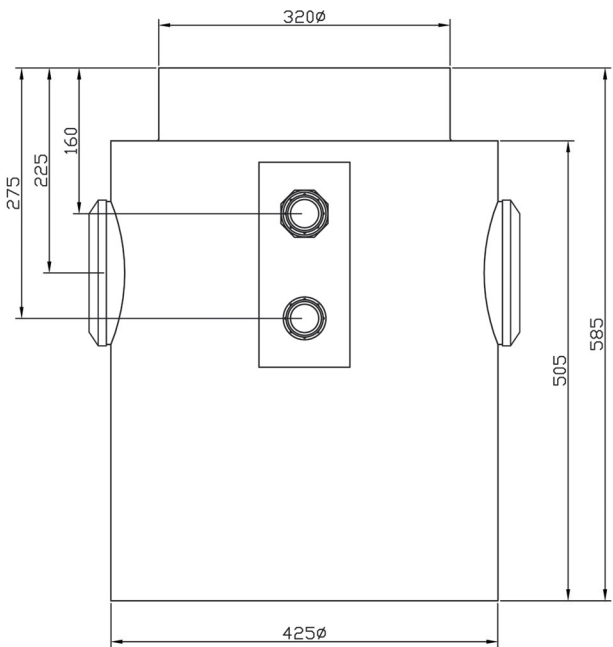
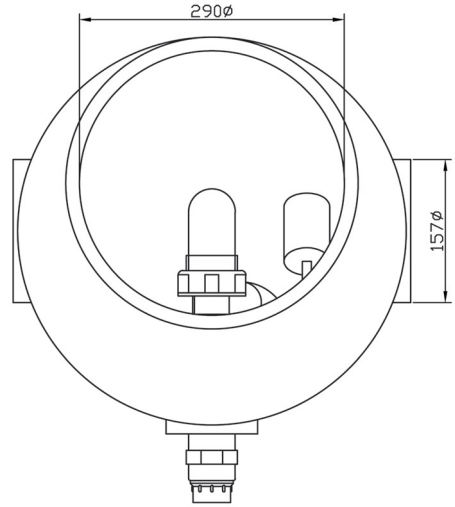
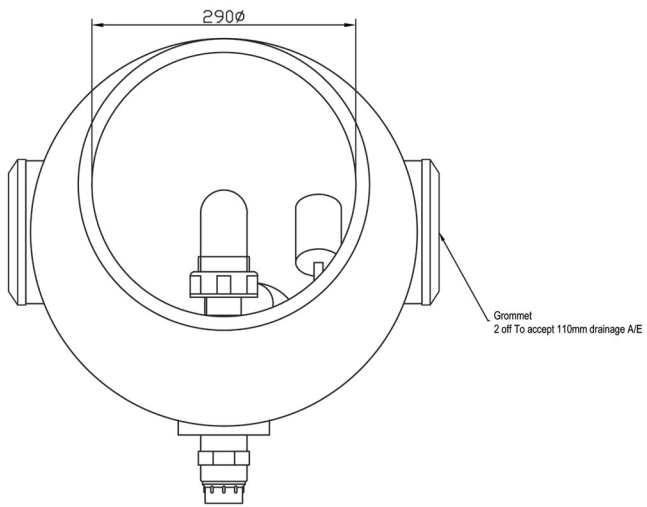

SINGLE SUMP - WITH INLETS

SINGLE SUMP - NO INLETS

DELTA HIGH LEVEL ALARM

Alarm unit warns the state of alarm of a pumping plant, even in case of power failure.

SW

ON: FLOAT SWITCH ALARM

TEST: CHECKS THE PROPER RUNNING OF THE ALARM DEVICE

CIRCUIT DIAGRAM

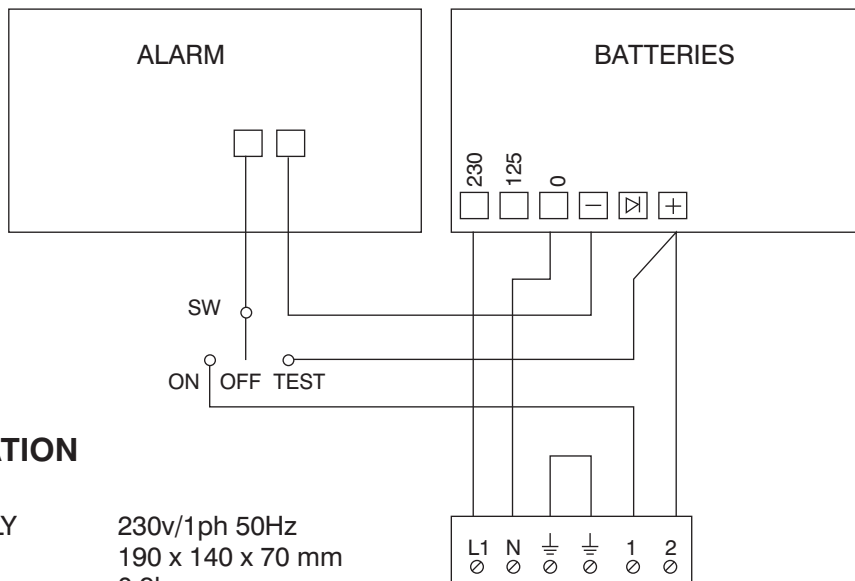

SPECIFICATION

MAINS SUPPLY	230v/1ph 50Hz
SIZE	190 x 140 x 70 mm
WEIGHT	0,9kg
BATTERY	Ni Cd 6Vcc - 0.5Ah
ALARM	102db/1m -35/6mA/V - F=2700HZ
VISUAL ALARM	LED D5
RESTORATION TIME FULLY CHARGE	APPROXIMATELY 12 HOURS
BATTERY OPERATING TIME	APPROXIMATELY 12 HOURS

TERMINAL 1 - BROWN
 TERMINAL 2 - BLACK
 DO NOT USE BLUE CORE FOR HIGH LEVEL ALARM APPLICATION >

High level alarm
 The Delta range of sump chambers can be fitted with a mains dependent / mains independent high-level alarm. An audible signal will be heard in case of pump failure. This alarm is normally operational from the mains power supply (240/1/50) however in case of a power cut the alarm is powered by a built in back up battery

Overall Size of Alarm Box:

- L = 198 mm
- W = 148 mm
- D = 106 mm

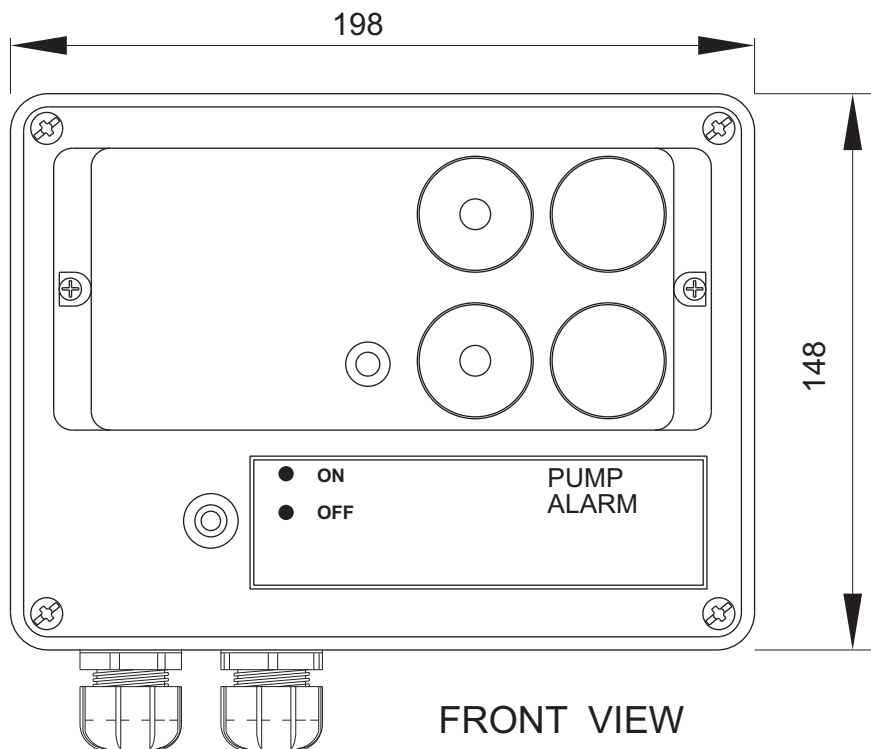

FRONT VIEW

DISTRIBUTED BY:
 Delta Membrane Systems Ltd.
 Delta House,
 Merlin Way, North Weald,
 Epping, Essex CM16 6AA



Telephone 01992 523523
 Fax 01992 523250
 Web www.deltamembranes.com
 Email info@deltamembranes.com