

# Delta Dual V3 (DMS-164)

## Installation Instructions For Ground Water Applications



**T.** 01992 523523  
**E.** [info@deltamembranes.com](mailto:info@deltamembranes.com)  
**W.** [www.deltamembranes.com](http://www.deltamembranes.com)



# Delta Dual V3

## **Legal information/Copyright**

All rights reserved. Contents provided herein must neither be distributed, copied, reproduced, edited or processed for any other purpose, nor otherwise transmitted, published or made available to a third party without express written consent from Delta Membranes.

Subject to technical modification without prior notice.

© Delta Membranes 2016

**DDV3-M-V2-03.16**

## Contents

1.0	Dual V3 Overview.....	4
2.0	Parts Included.....	4
2.1	Optional Extras.....	4
3.0	Discharge Pipework & Fittings.....	5
4.0	Chamber Overview.....	6
5.0	Spare Parts.....	6
6.0	Technical Information.....	7
7.0	Pump Chamber Depth Limits.....	8
8.0	Installation Guidelines.....	9
9.0	Pump Station Location.....	9
10.0	RC Box Dimensions.....	9
11.0	Installation of Chamber.....	10
	Section A - Construction of reinforced concrete box.....	10
	Section B1 - Connecting 110mm pipework.....	11
	Section B2 - Connecting perimeter channel to chamber.....	12
	Section B3 - Connecting perimeter channel via a 1.5"/40mm inlet pipe.....	13
	Section C - Connecting discharge and cable duct.....	14
	Section D1 - Backfill around chamber with concrete (RC Box).....	16
	Section D2 - Backfill around chamber with concrete (Ground).....	17
	Section D3 - Backfill around chamber with concrete (Reinforced cage).....	18
	Section E - Installing pumps and high level alarm in chamber.....	19
12.0	Wiring Diagram.....	22
13.0	Maintenance.....	23
14.0	Health and Safety.....	23
15.0	Guarantee.....	23
16.0	Troubleshooting.....	24
17.0	Self Commissioning.....	25
18.0	Notes.....	27

# Delta Dual V3

## 1.0 Dual V3 Overview

The Delta Dual V3 is a packaged pump station designed to collect ground water via perimeter channel or Delta 129 detail and/or clear opening to the top of the chamber - please visit our website for water collection details. Typically, the Dual V3 would be used to collect ground water from a basement up to 150m<sup>2</sup> and/or surface water from a light well up to 12m<sup>2</sup> to a maximum head of 3.5m

The pump station has been specifically designed for below ground applications. The chamber is manufactured from HDPE and when installed correctly, it is able to withstand hydrostatic forces encountered in high water tables.

The pump station is delivered as a complete package including, the chamber, internal pipework and two powerful V3 pumps. It is designed to be installed by contractors with competent building, plumbing and electrical skills. The pumps operate by fixed arm floats, the duty pump is set at a standard height (210mm to base of float) and the backup pump is set at a high level (380mm to base of float). The high level alarm (where fitted) will operate if the duty pump fails leaving the backup pump to discharge water.

A high level alarm (DMS-270) is offered as a recommended extra to alert the property occupant when the water level in the chamber becomes too high. A battery backup (DMS-280) is recommended to power the pumps during power outage. Please see section 2.1 for more details about optional extras designed for the Dual V3 pump station.

## 2.0 Parts Included



Chamber  
902 x 655mm deep



1.25" Internal Pipework

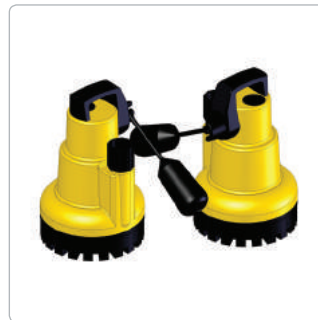

2 x V3 Pumps



1.25" Discharge Male Iron  
for temp. site installation.  
2" Cable Duct Male Iron

## 2.1 Optional Extras



AlertMaxx High Level  
Alarm (DMS-270)



PowerMaxx Battery  
Backup (DMS-070)



1.25" Discharge Pipework  
and various fittings

## 3.0 Discharge Pipework & Fittings

A selection of discharge pipework and fittings are available for the Dual V3 pump station.

Should you require to place an order for any of these items, please complete the form below, scan and email to [purchasing@deltamembranes.com](mailto:purchasing@deltamembranes.com) to allow us to process your order.

Part Description	Part No.	Qty Req.
1.25" Pipe - 3m Length (Class E)	DMS-0144	
1.25" 90° Elbow - Plain/Plain	DMS-0145	
1.25" 45° Elbow - Plain/Plain	DMS-0146	
1.25" Socket - Plain/Plain	DMS-0147	
1.25" Socket - BSP Mail Thread/BSP Male Thread	DMS-331	
1.25" Male Iron - Plain/BSP Male Thread	DMS-0143	
1.25" Male Iron - Plain/BSP Male Thread (Non-pressure)	DMS-332	
110mm to 1.25" Adaptor	DMS-340	
Saddle Clamp - 110mm to 1.25" (BSP Female Thread) including 1.25" Male Iron	DMS-0141	
Saddle Clamp - 160mm to 1.25" (BSP Female Thread) including 1.25" Male Iron	DMS-0142	
1.25" Pipe Clip	DMS-049	
500ml PVC Solvent Cement	DMS-0158	

<b>Name:</b>	
<b>Company Name:</b>	
<b>Property Address:</b>	
<b>Email:</b>	
<b>Phone No.:</b>	<b>Mobile No.:</b>

<b>Sign:</b>	<b>Date:</b>
--------------	--------------

# Delta Dual V3

## 4.0 Chamber Overview

Part	Description
A	Inlet Pipe
B	Concrete Base
C	Inspection Cover
D	Pump Chamber
E	Cable Duct
F	Fused Spur

G	Distribution Board
H	High Level Alarm Box
I	Screed
J	Insulation
K	MS20
L	Basement Slab

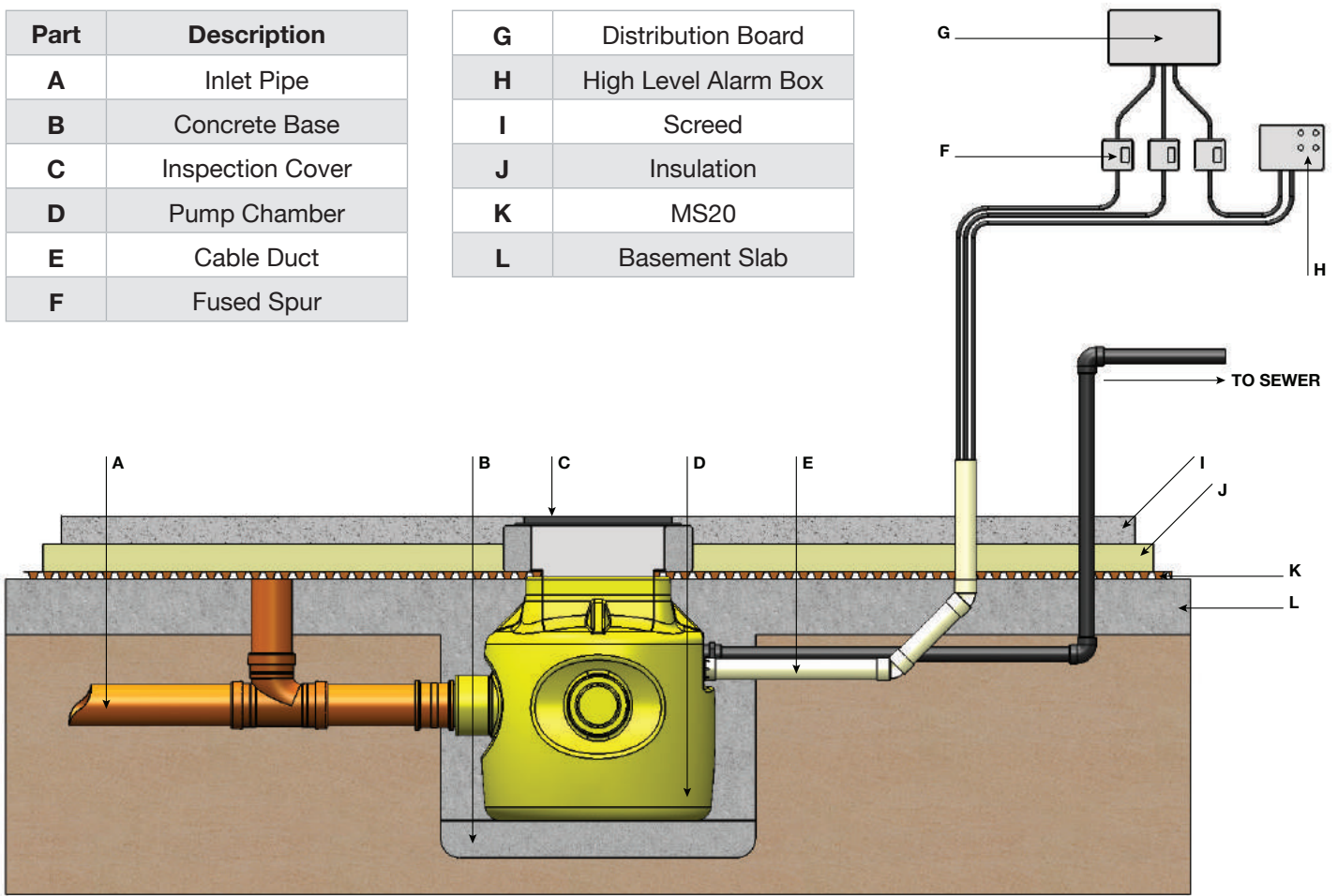

## 5.0 Spare Parts

Part	Description	Part No.
1	V3 Pump c/w 1.1 & 1.2	DMS-116
1.1	Float & Switch Assembly	DMS-344
1.2	Non-return Valve	DMS-328
2	Discharge Arm	DMS-146
3	'O' Ring	DMS-132
4	1.25" Brass Gate Valve	DMS-329
5	Connector Piece	DMS-330
6	1.25" BSP/BSP Socket	DMS-331
7	1.25" Non-pressure Male Iron	DMS-332
8	2" Non-pressure Male Iron	DMS-335
9	Y-piece c/w 2 'O' rings	DMS-321

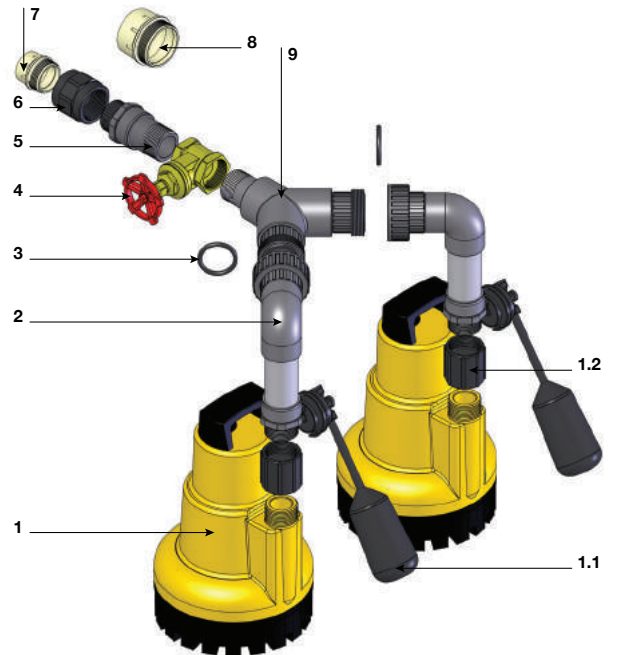

## 6.0 Technical Information

Pump Specification			
Pump Type			V3
Typical Duty (l/s)	Head (m)	3	2.25
		3.5	2.10
		4	1.85
		4.5	1.65
		5	1.35
		6	0.70
Power		P <sub>1</sub> (kW)	0.43
		P <sub>2</sub> (kW)	0.18
Current (a)			1.90
Power Phase			Single
Fuse Spur Rating (a)			13
Max. Temperature (°C)			50
Weight (kg)			5.64

Chamber Specification		
Chamber Material	High Density Polyethylene - ICO1314 grade	
Size (mm)	Chamber Diameter	660
	Overall Diameter	902 (across spigots)
	Depth	655
Volume (L)	Below Inlet	87
	Total	217
Inspection Cover	Not supplied	
Clear opening to chamber (mm)	310 x 310	
Fixed Inlets	3 x 110 / 160mm	
Cable Duct (mm)	50	
Vent	N/A	
Discharge Connection	1.25" / 32mm BSP Male - External to chamber	
Internal Pipework Manifold	1.25" / 32mm BSP Class E	
RCBO Rating (a)	16	
Cable Length (m)	10	
Non-switched Fuse Spur Rating (a)	13	

# Delta Dual V3

## 7.0 Pump Chamber Depth Limits

If the inlet does not allow the pump chamber to be within depth limits, please contact PPS on 01279 757400 to discuss chamber options.

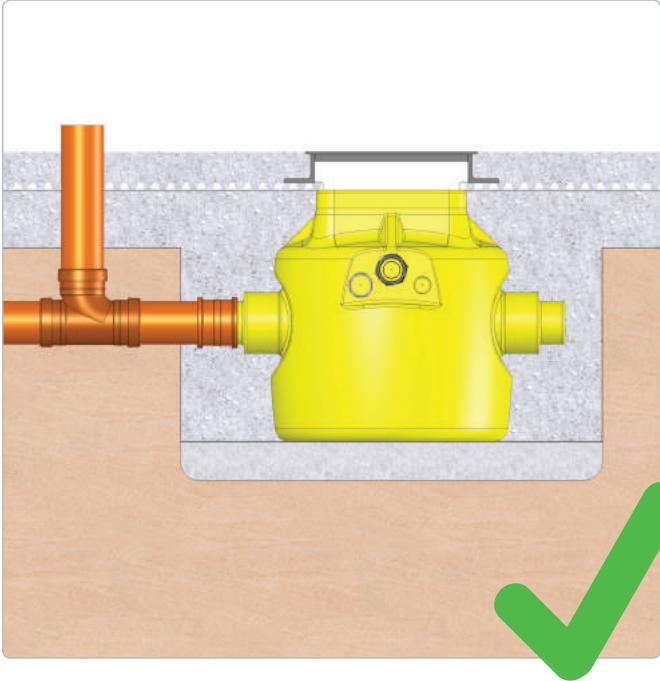

< 500mm

The pump chamber must be installed no more than 500mm below floor finishes.

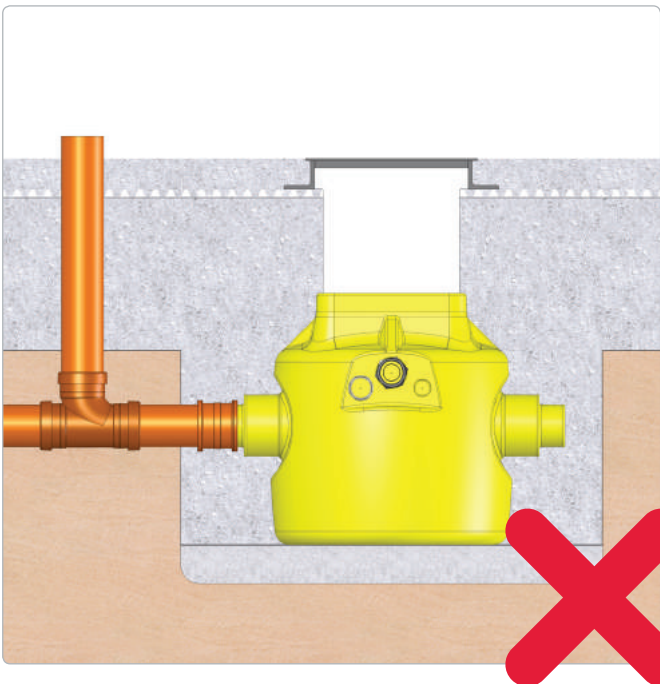

> 500mm

A pump chamber installed more than 500mm below floor finishes cannot be serviced safely in accordance with CDM regulations.

## 8.0 Installation Guidelines

The following instructions are for guidance only and it is the contractor's responsibility to ensure that the installation is in accordance with the prevailing ground conditions and good building practice, to eliminate any potential damage to the pump station either during or after installation.

Please read these instructions carefully prior to installing the chamber. If there is anything that is unclear, our technical help desk is available on 01279 757400.

## 9.0 Pump Station Location

This station requires routine maintenance, therefore it is important that careful consideration is taken to position the chamber in a location that allows permanent access to the chamber.

## 10.0 RC Box Dimensions

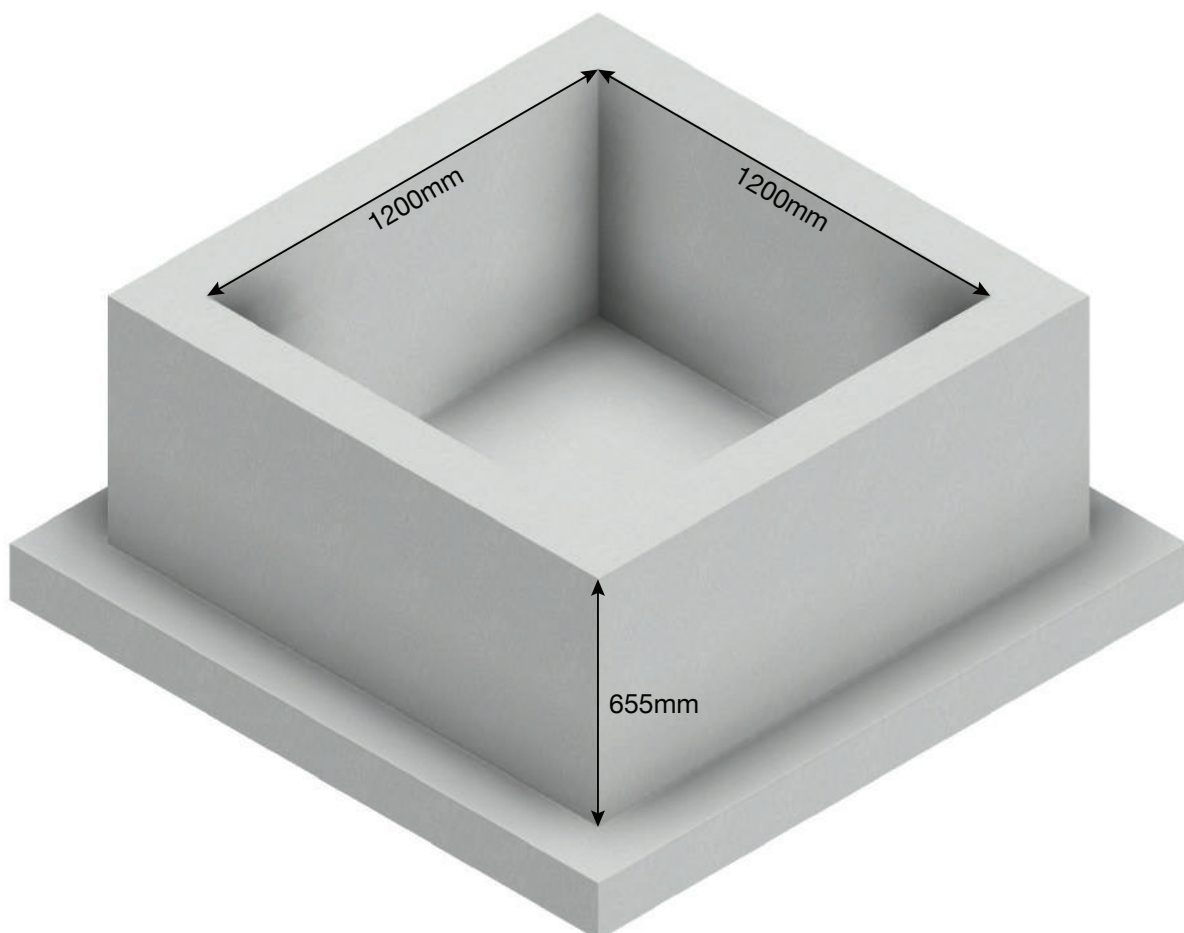

Approx. scale 1:20

# Delta Dual V3

## 11.0 Installation of Chamber - Section A

### Construction of reinforced concrete box



Excavate hole for chamber. Refer to section 10.0 for RC box internal dimensions.

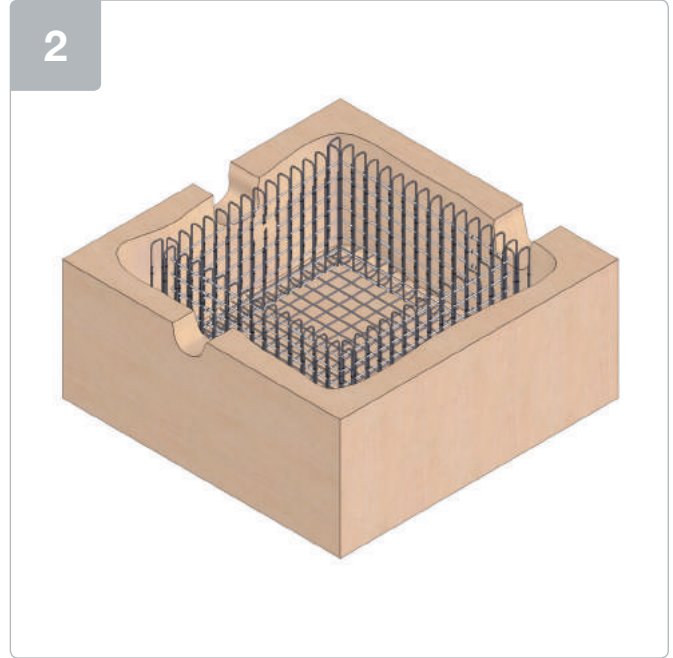

Install re-bar as per structural engineer's drawings.



Lay inlet and discharge pipework. Allow pipework to protrude into RC box by a minimum of 100mm.

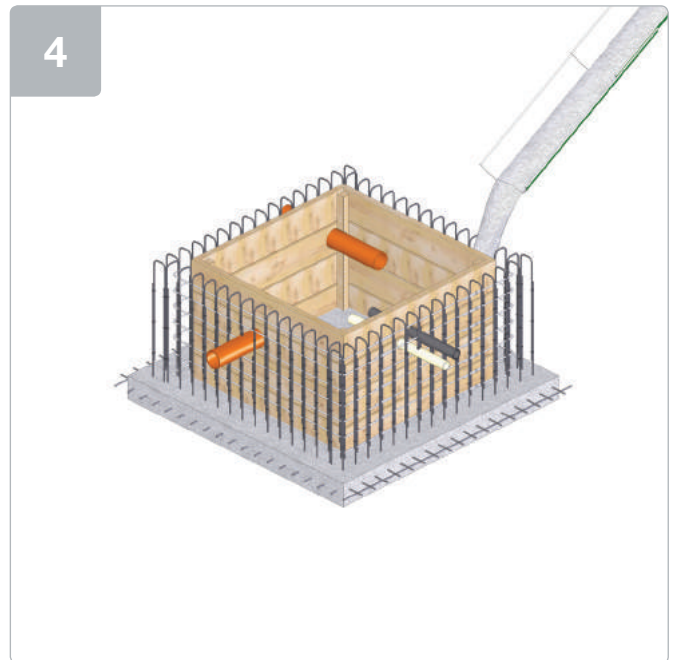

Pour concrete to form RC box as per structural engineer's drawings.

## 11.0 Installation of Chamber - Section B1

### Connecting 110mm pipework



Saw off socket end/s, where inlet pipe/s are to be connected.

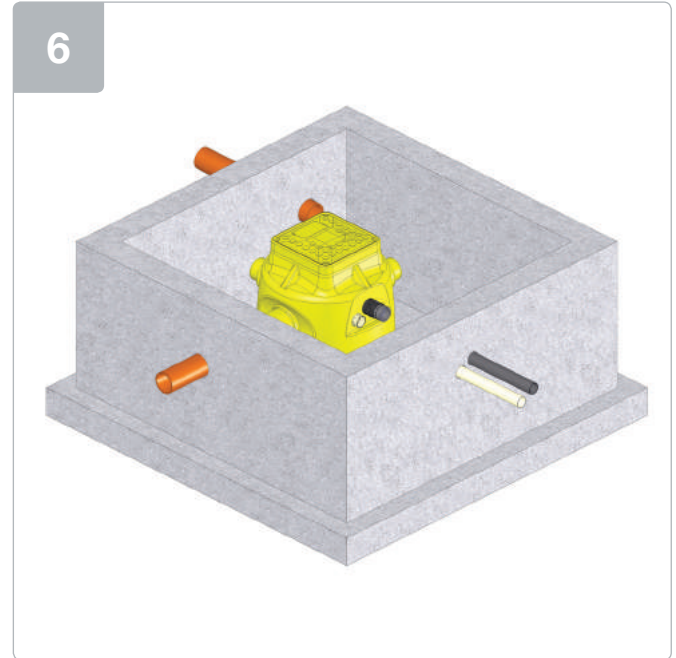

Position chamber in RC box.

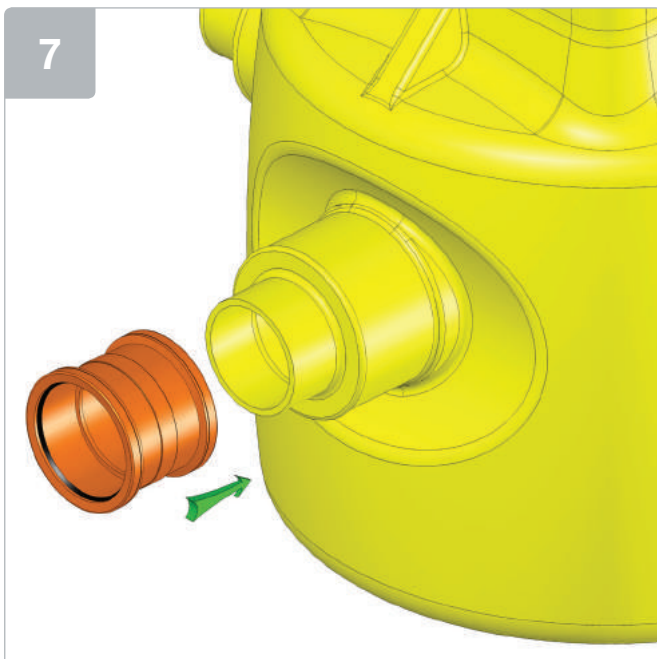

Fit push fit coupler.

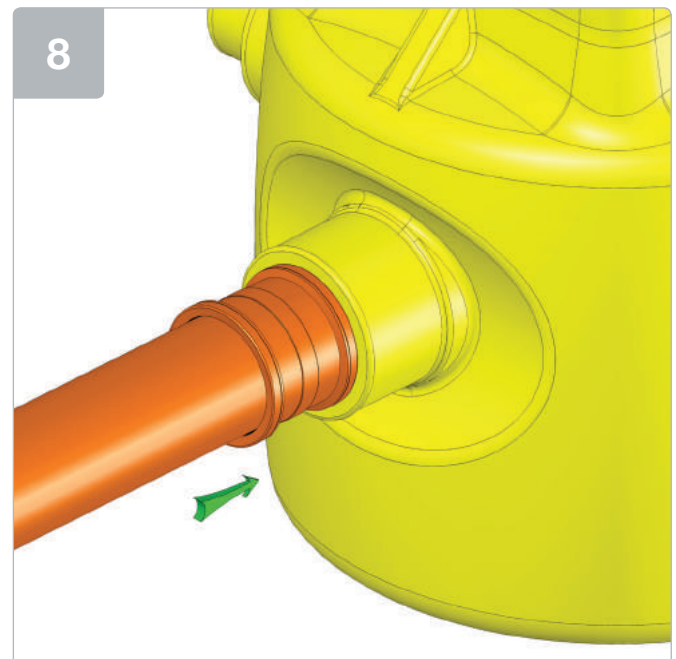

Connect inlet pipework to the required chamber spigot.

# Delta Dual V3

## 11.0 Installation of Chamber - Section B2

### Connecting perimeter channel to chamber

To be followed when installing perimeter channel directly into upper side of chamber.

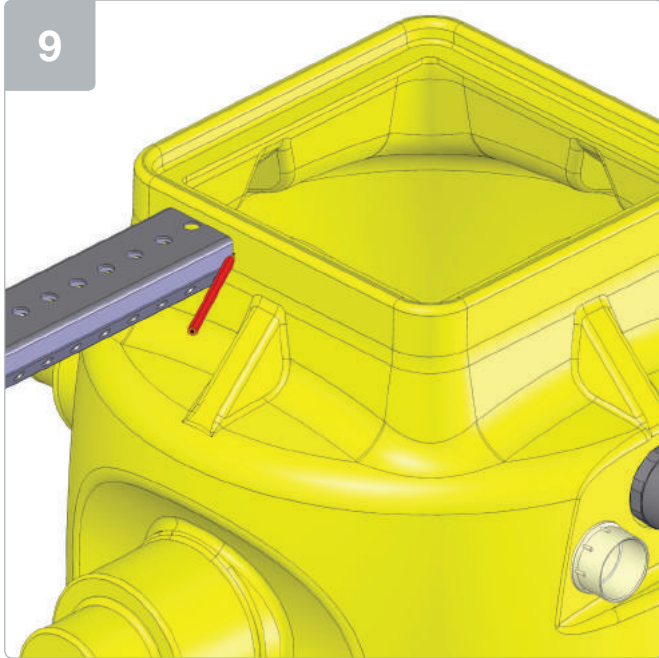

Mark perimeter channel position on side of chamber.

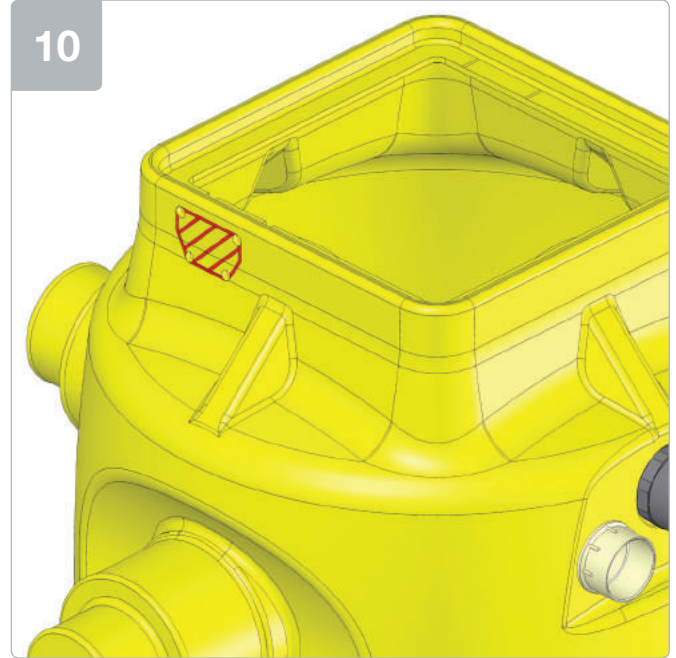

Drill holes in the corners inside the area marked in red.

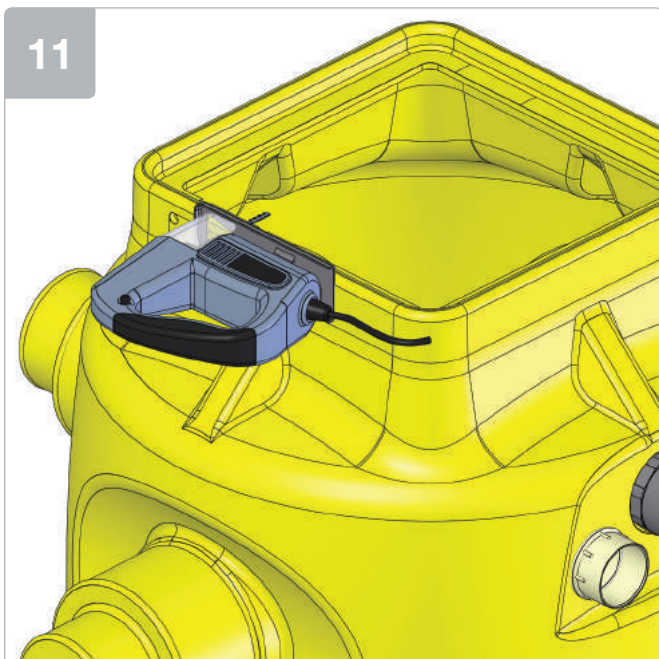

Cut around the marked line outlining the perimeter channel using a jigsaw.

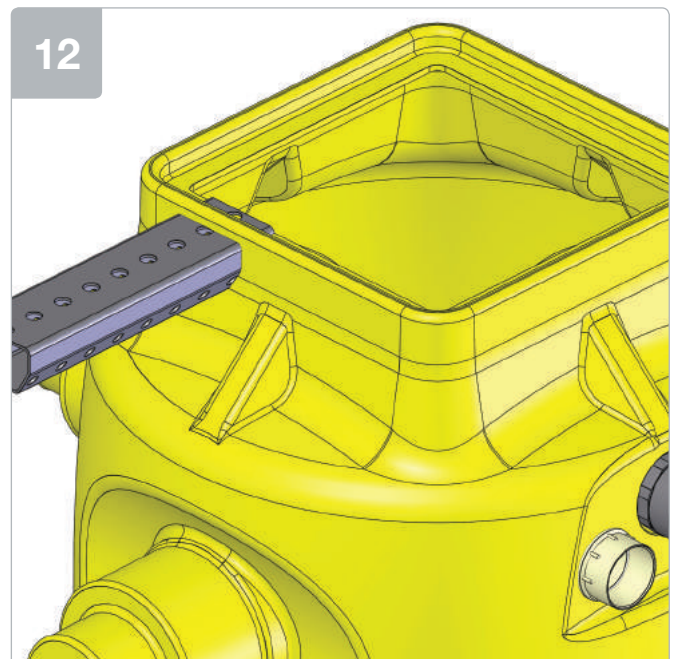

Insert the perimeter channel into the chamber allowing 35mm of overhang inside the chamber.

## 11.0 Installation of Chamber - Section B3

### Connecting perimeter channel via a 1.5"/40mm inlet pipe

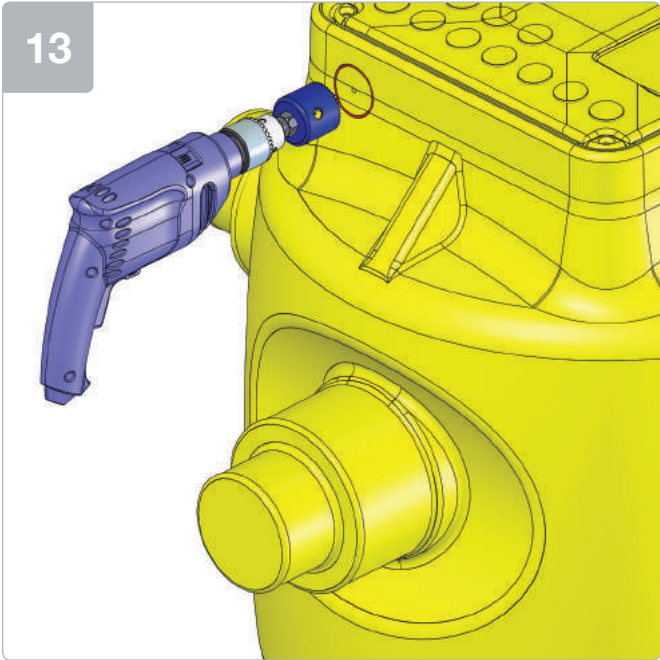

Mark position of the 40mm pipe on the side of the chamber and cut out the marked line using a 1.5"/40mm holesaw.

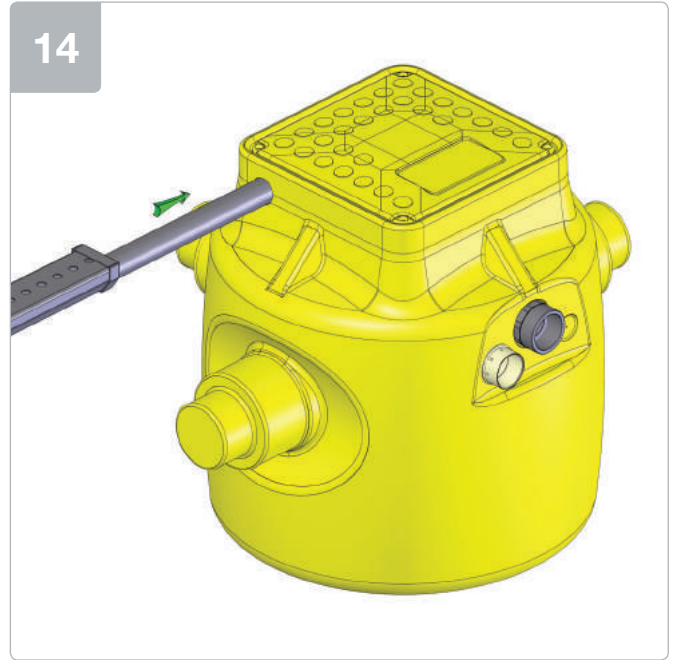

Cut 40mm pipe to length allowing an overhang of 35mm inside the chamber.



Saw off 110mm socket end/s to be used.

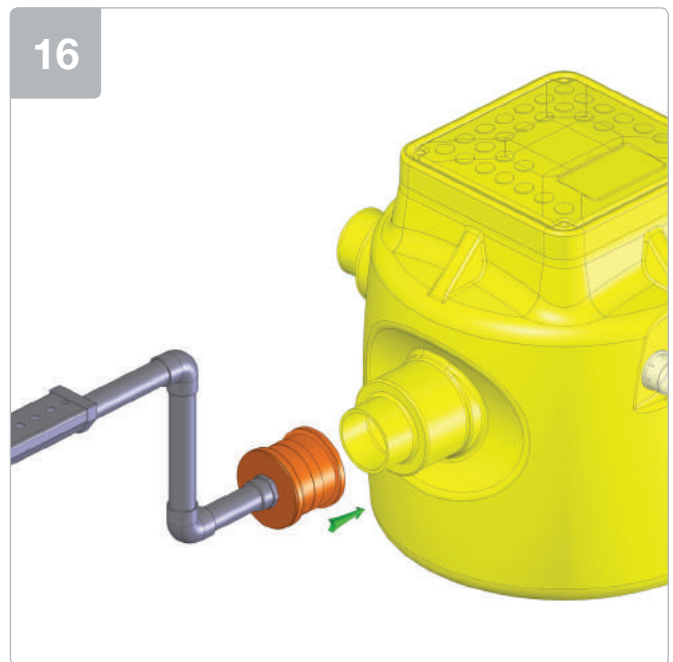

Attach a DMS-341 adaptor to the 40mm pipe and connect the adaptor to the chamber via a 110mm push fit coupler.

# Delta Dual V3

## 11.0 Installation of Chamber - Section C

### Connecting discharge and cable duct



Wrap the thread on a DMS-0143 high pressure male iron with PTFE tape.

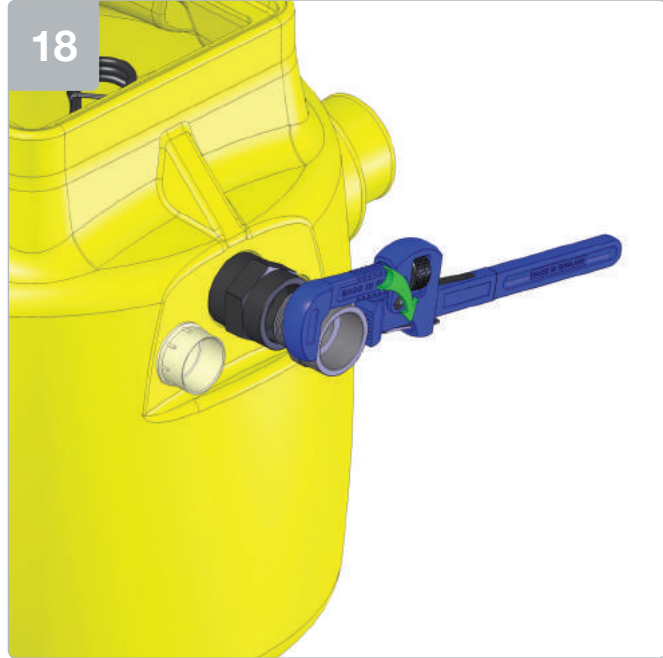

Screw the high pressure male iron into the female iron.

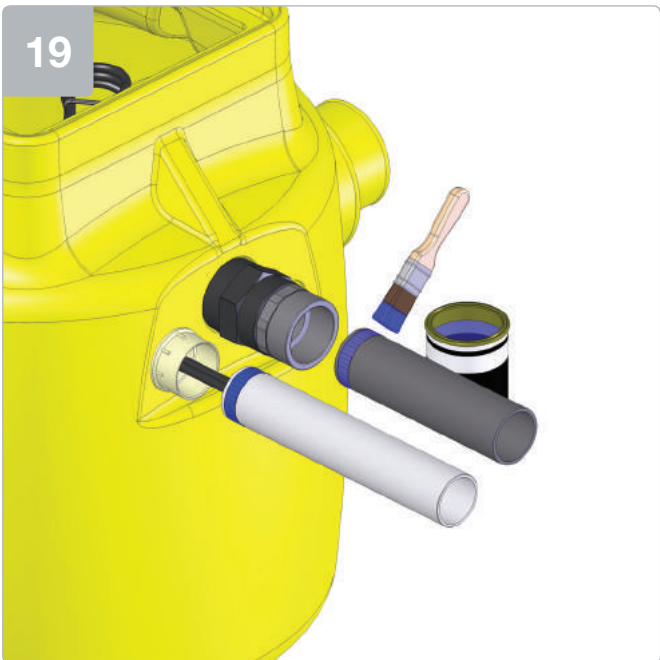

Apply DMS-0158 high pressure glue around the first 20mm of the external face of the discharge and cable duct pipe and internal side of their respective male iron.

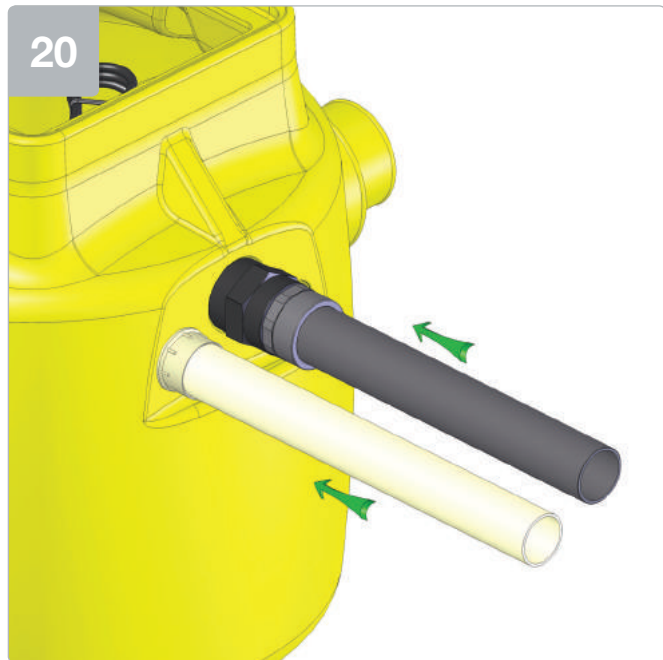

Push discharge and cable duct pipe into their respective male iron, twisting the pipe as it is pushed into the male iron to remove any trapped air.

## 11.0 Installation of Chamber - Section C cont.

### Connecting discharge and cable duct



Ensure a draw cord is pulled through the cable duct as the cable duct is built.

# Delta Dual V3

## 11.0 Installation of Chamber - Section D1

### Backfill around chamber with concrete

To be followed when installing chamber in an RC box.

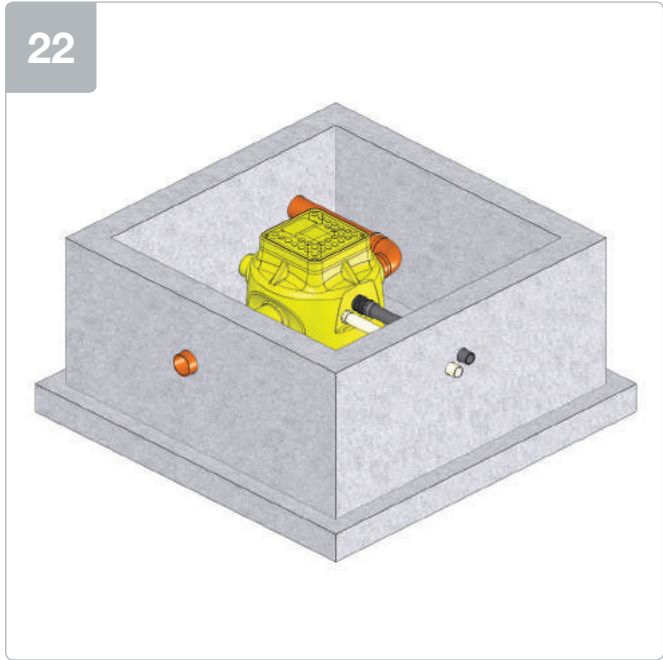

Check all pipes are connected to the chamber correctly.

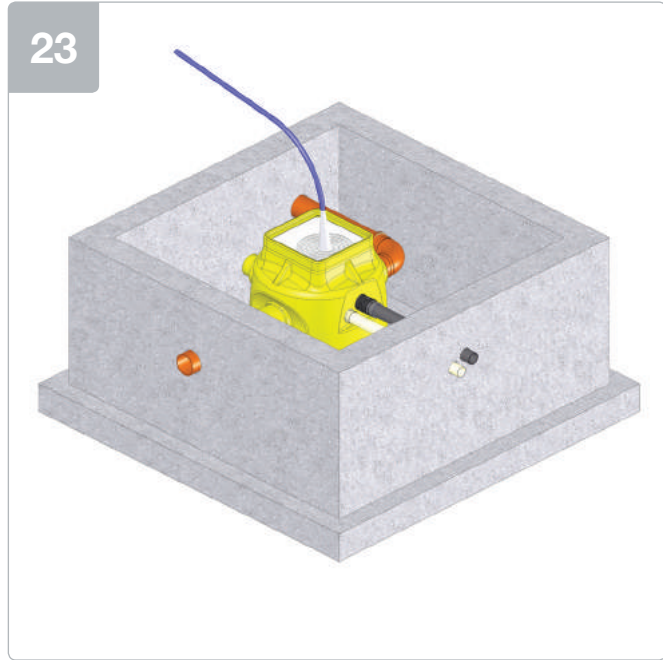

Completely fill chamber with water.

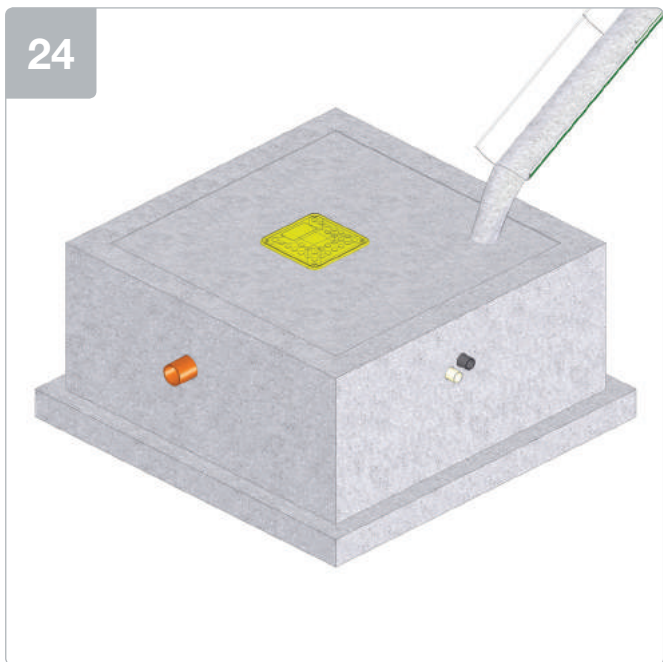

Fill void between RC box and chamber with concrete (min. C35 grade) or as per engineer's drawings.

## 11.0 Installation of Chamber - Section D2

### Backfill around chamber with concrete

To be followed when installing chamber in the ground.

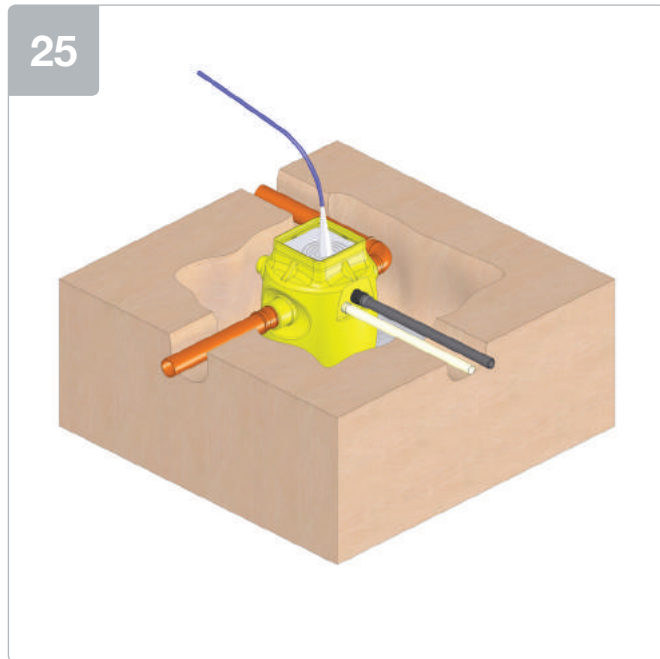

Completely fill chamber with water.

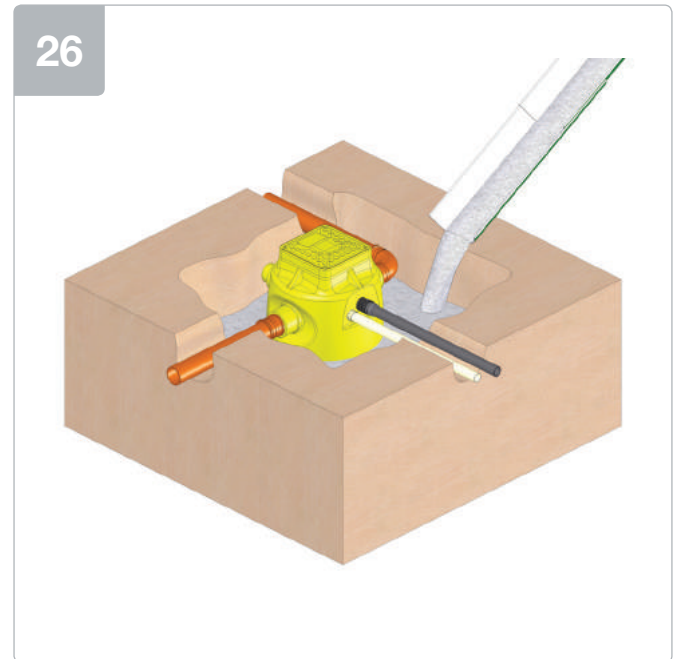

Fill void between soil and chamber with concrete (min. C35 grade) or as per engineer's drawings.



Allow concrete to cure.

# Delta Dual V3

## 11.0 Installation of Chamber - Section D3

### Backfill around chamber with concrete

To be followed when installing chamber in the ground with a reinforced cage.

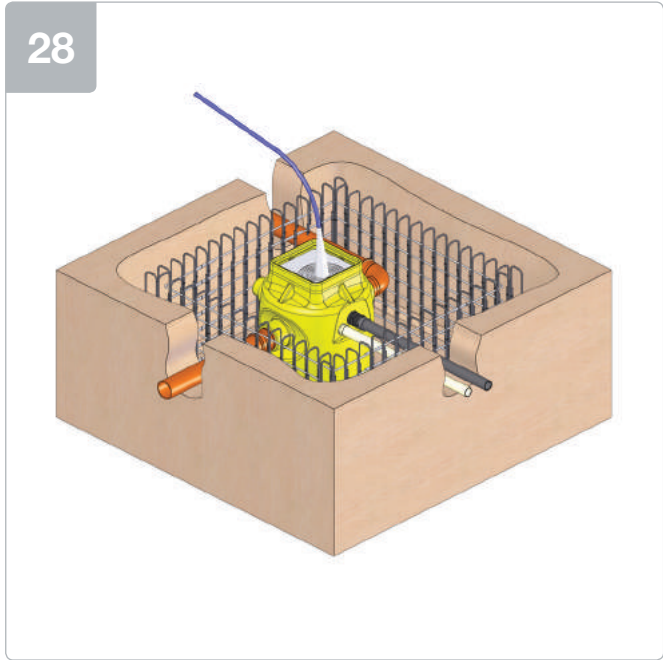

Completely fill chamber with water.

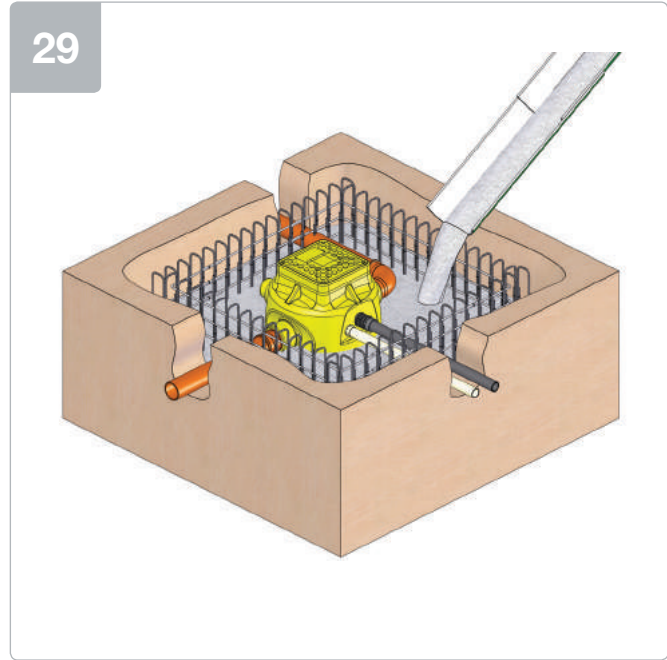

Fill void between soil and chamber with concrete (min. C35 grade) or as per engineer's drawings.



Allow concrete to cure.

11.0 Installation of Chamber - Section E

Installing pumps and high level alarm in chamber

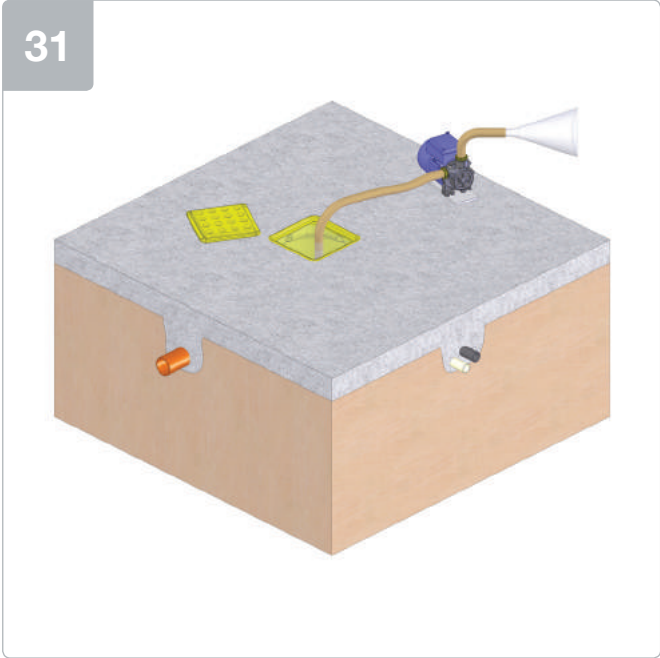

Pump out water from chamber.



Manually remove any debris from chamber and residual water using a wet vac.

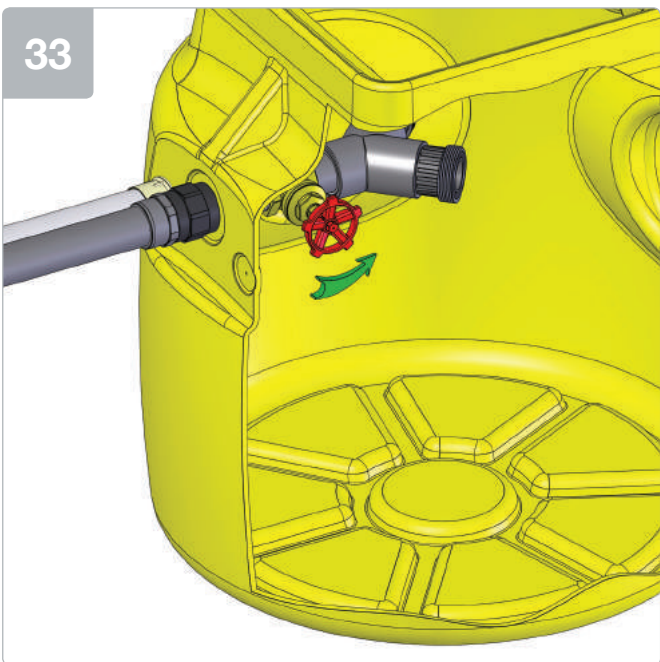

Remove discharge arms from 'Y' piece manifold and screw 'Y' piece on to gatevalve. Ensure gatevalve is fully open.



Wrap PTFE tape around thread located on male irons at the bottom of the discharge arms and screw discharge arms on to pumps.

# Delta Dual V3

## 11.0 Installation of Chamber - Section E cont.

### Installing pumps and high level alarm in chamber

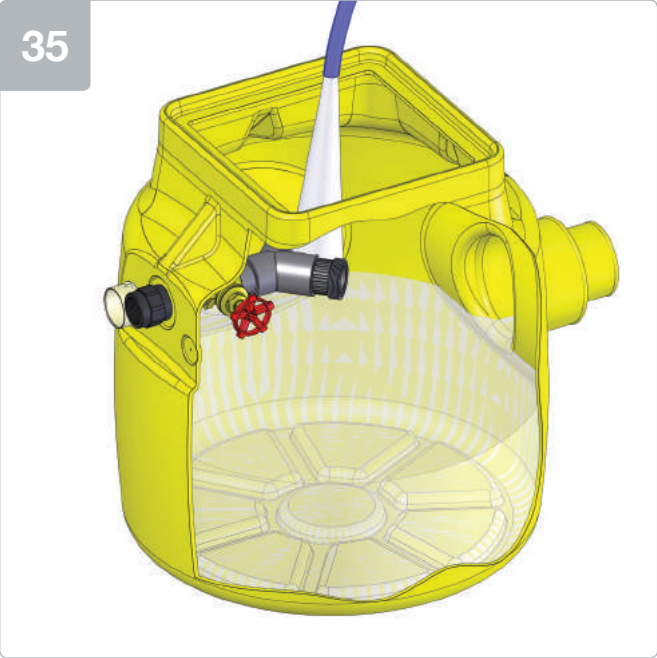

Fill chamber half full with water.



Lower pumps in to chamber. Ensure 'O' rings are correctly seated in unions and screw discharge arms to 'Y' piece manifold.



When installing a high level alarm, refer to the high level alarm installation instructions.

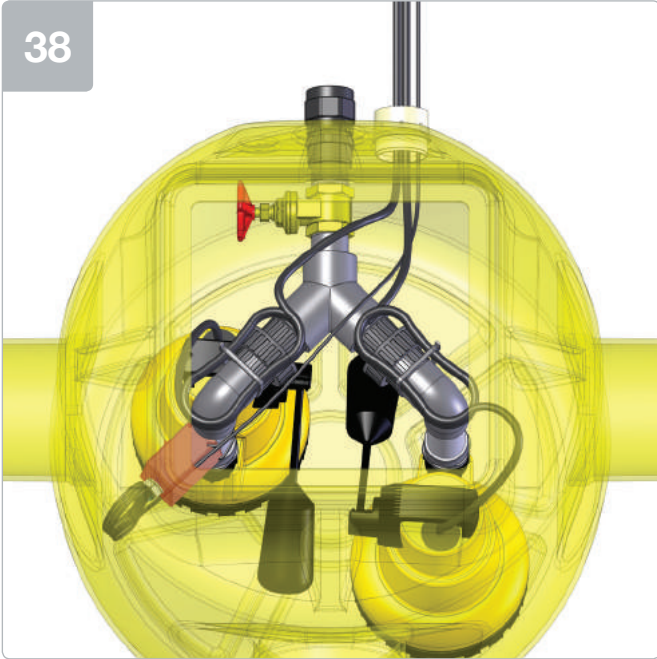

Pull pump and high level alarm cables through cable duct.

## 11.0 Installation of Chamber - Section E cont.

### Installing pumps and high level alarm in chamber

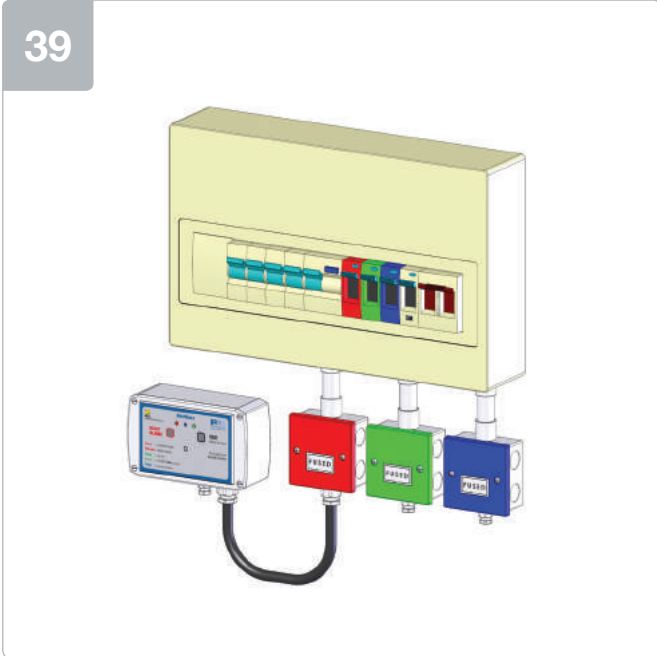

Isolate main supply and connect each pump and high level alarm cable to a separate non-switched fused spur.



Turn mains supply on and lift each pumps float arm to test water is discharging correctly.



To test float switch, refer to the high level alarm installation instructions.



Re-fit temporary site cover to protect the pump station.

## 12.0 Wiring Diagram

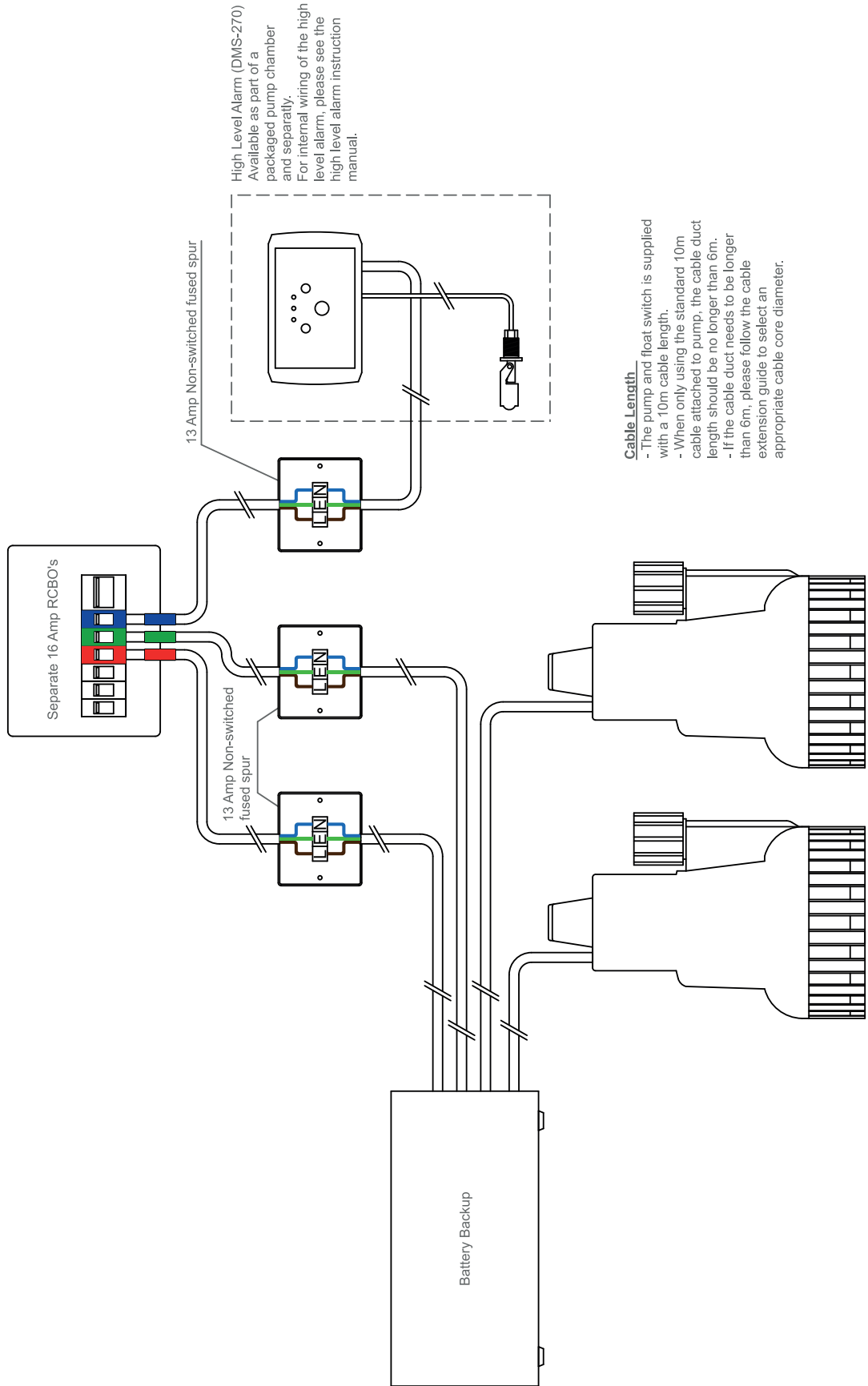

High Level Alarm (DMS-270)  
Available as part of a packaged pump chamber and separately.  
For internal wiring of the high level alarm, please see the high level alarm instruction manual.

**Cable Length**  
- The pump and float switch is supplied with a 10m cable length.  
- When only using the standard 10m cable attached to pump, the cable duct length should be no longer than 6m.  
- If the cable duct needs to be longer than 6m, please follow the cable extension guide to select an appropriate cable core diameter.

## 13.0 Maintenance

British Standards requires pump chambers to be serviced on a regular basis to ensure reliable operation of equipment. PPS recommends that the pump station is serviced biannually.

PPS strongly recommends that a service agreement is taken out, please see the back page for further information.

## 14.0 Health and Safety

In order to minimise the risk of accidents when installing and servicing pump chambers, the following health and safety guidelines should be followed:

- Obey all health and safety hazards.
- Observe strict cleanliness.
- Ensure power to the pump chamber is isolated before carrying out any maintenance to the pump chamber.
- Always ensure correct PPE is worn.
- All personnel working with sewage chambers must be vaccinated against diseases to which they may be exposed to.
- A first aid kit must be close to hand.

## 15.0 Guarantee

The Dual V3 pump chamber comes with a 12 month component guarantee, which covers any manufacturing faults and defects as a result of poor workmanship.

Pump chambers that have not been commissioned have a 12 month component guarantee from date of delivery. Pump chambers that have been commissioned have a 12 month component guarantee from date of commissioning.

Any defects or malfunctions should be reported to Delta Membranes immediately to avoid any damage to other components. All broken components must be sent to Delta Membranes at the customers cost. Any pumps to be returned must be returned complete with their cable attached.

We exclude all liability for any consequential or other damage or losses which may occur. We will not be liable if the pumping system fails due to it having been incorrectly specified (e.g. where a pump is subjected to flow rates higher than recommended or where a pump is used to discharge inappropriate fluids/solids, such as building debris or materials).

# Delta Dual V3

## 16.0 Troubleshooting

Please ensure the installation process has been completed thoroughly and all steps have been followed correctly.

Use the table below to assist with troubleshooting and if problems still occur, please contact PPS for further technical support on 01279 757400.

Fault	Cause
Water leaking from discharge arms.	<p>'O' rings missing or not installed correctly in unions.</p> <p>PTFE tape not applied to male irons on discharge arms when attached to pumps.</p>
Pump isn't running.	<p>Pump hasn't got power - check wiring with reference to section 12.0 wiring diagram.</p> <p>Float arm isn't lifting - check float arm is free moving and not catching on chamber or other pump - make sure pumps are positioned as diagram 36.</p> <p>Float arm not turning on pump - can you hear a click when lifted slowly? If not, call PPS for further assistance.</p>
Pump running but not pumping water or discharging very slow (more than 40 seconds to empty chamber).	<p>Gate valve isn't open or partially closed - turn valve anticlockwise to open.</p> <p>Pump is air locked - make sure there is a level of water to the top of the pumps, remove pump from union and lower back into water, lift float arm to activate pump before reconnecting to discharge arm.</p> <p>Discharge pipe is blocked - a drainage company is required.</p> <p>Pump impellor is jammed - turn off power and isolate pump, remove pump from chamber, unscrew pump base using Torx screwdriver and free impellor.</p> <div data-bbox="807 1453 1489 1565" style="background-color: red; color: black; padding: 5px; text-align: center;"> <p><b>WARNING! - Insure mains power and pump is isolated before taking pump apart and seek advice from a qualified electrician.</b></p> </div>
Pump is tripping.	<p>Pump is wired incorrectly or not on a separate supply - refer to section 12.0 wiring diagram.</p> <p>Pump impellor is jammed - turn off power and isolate pump, remove pump from chamber, unscrew pump base using Torx screwdriver and free impellor.</p> <div data-bbox="807 1816 1489 1928" style="background-color: red; color: black; padding: 5px; text-align: center;"> <p><b>WARNING! - Insure mains power and pump is isolated before taking pump apart and seek advice from a qualified electrician.</b></p> </div>
High Level Alarm not functioning.	<p>Refer to the high level alarm installation &amp; operating instructions.</p>

## 17.0 Self Commissioning

<b>Name:</b>	<b>Inspectors Name:</b>
<b>Property Address:</b>	<b>Company Name &amp; Address:</b>
<b>Property Contact:</b>	<b>Company Contact:</b>
<b>Date complete:</b>	

<b>Location of Chamber:</b>	<b>Location of Alarm:</b>	<b>Location of Electrics:</b>
<b>Pump 1 Serial Number:</b>		<b>Pump 2 Serial Number:</b>

<b>Commissioning requirements</b>	<b>Complete</b>
Chamber is clear of silt and debris.	
Check activation of float switches by hand making sure they can operate without obstruction. Cable joining kits (if fitted) to be moved away from pumps/floats and secured.	
Turn gate valve anticlockwise to ensure it is fully open.	
Electrically isolate pump set to standard height (duty pump), fill chamber with water and check pump discharges in less than 40 seconds.	
While standard height pump is isolated, fill chamber with water and check the high level alarm sounds (alarm should operate between pump 1 and pump 2).	
Electrically isolate pump set to high level (backup pump), fill chamber with water and check pump discharges in less than 40 seconds.	
Check pipework is connected correctly (look for leaks).	
Check all cables are securely cable tied to manifold and clear of float switches.	
Check each pump is wired to an individual 13A non-switched spur.	
Check each spur is wired to an individual 16A RCBO (not RCD).	
Label spurs using stickers provided.	
Check power is on.	
Check battery backup is switched on correctly if available (refer to manual).	
Any additional comments: (further space overleaf)	

<b>Property Signature:</b>	<b>Inspectors Signature:</b>
<b>Print Name:</b>	<b>Print Name:</b>
<b>Date:</b>	<b>Date:</b>



Further comments:

18.0 Notes

A large, empty rectangular box with a thin black border, occupying most of the page. It is intended for the user to write notes.

# After Sales Service

All Delta Membrane pump systems are fitted & can be maintained by our partners, Packaged Pump Systems. With our long-term relationship we ensure that the system selected is fit for your requirements, is delivered on time, professionally installed & offers hassle free on-going operation & maintenance.

- Fully stocked vans
- Emergency breakdown service
- Out of hours service
- Planned maintenance
- Factory trained engineers



## Precise Passionate Service



### Precise

Fully trained in-house service engineers to maintain, enhance & replace equipment.

### Passionate

Bespoke design, manufacturing & installation ensuring our equipment is fit for every requirement.

### Service

From fitting to scheduled maintenance, we ensure your needs come first.

**T.** 01279 757400  
**E.** info@ppsgroupuk.com  
**W.** www.ppsgroupuk.com

Unit 12, Haslemere Ind. Est., Pig Lane, Bishop's Stortford. CM23 3HG

