

Dacatie Green Building Solutions - Product Drawing

Quantum Profile Systems Ltd.
Salmon Fields, Royton, Oldham, Lancashire, OL2 6JG
Tel: 0161 627 4222 Fax: 0161 627 4333 email: info@quantum-ps.co.uk

DACATIE
GREEN BUILDING SOLUTIONS

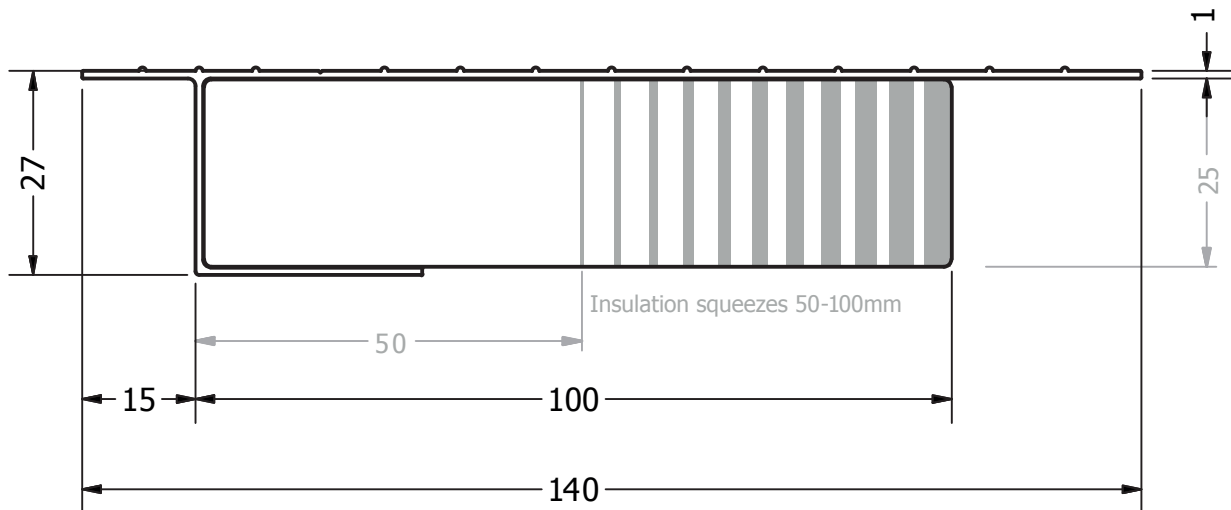
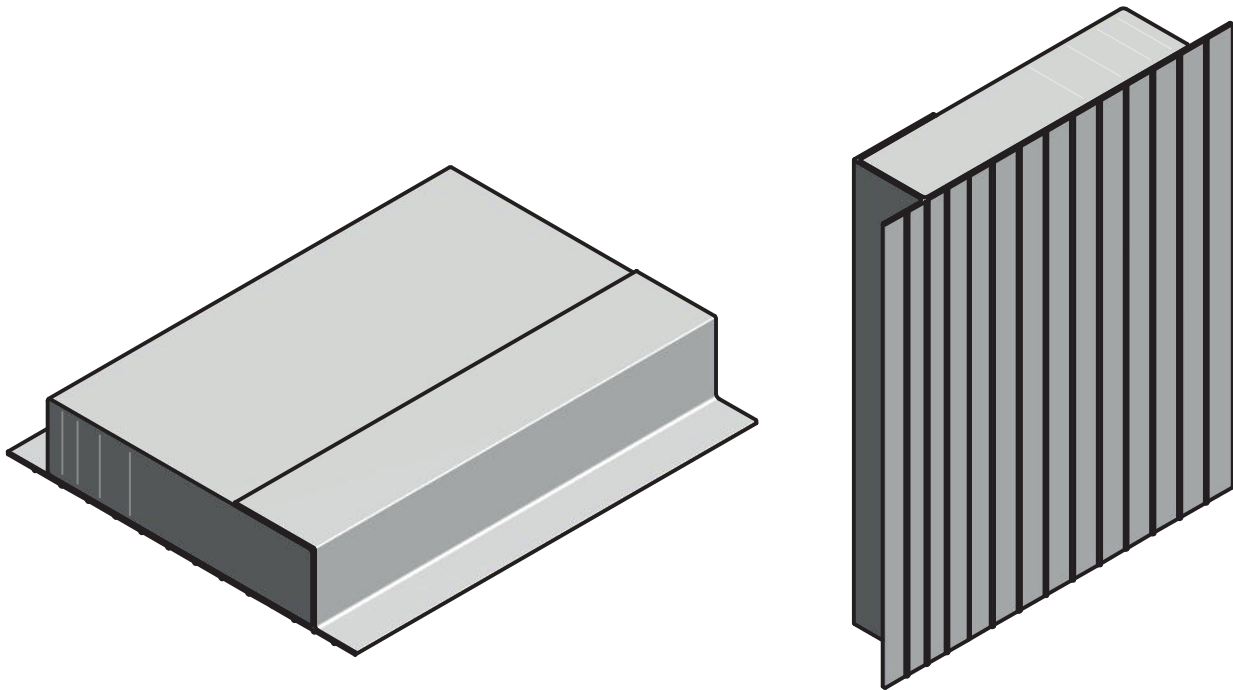

Product: Supafix Flexicloser Cavity Closer

Scale: 1:1

Material: uPVC, Mineral Wool



QPSL

This drawing should be used for illustration purposes only. It cannot be used as a specification of the part.
For more information please call 0161 627 4222 or mailto: CustomerService@quantum-ps.co.uk