

VCD 203 drive

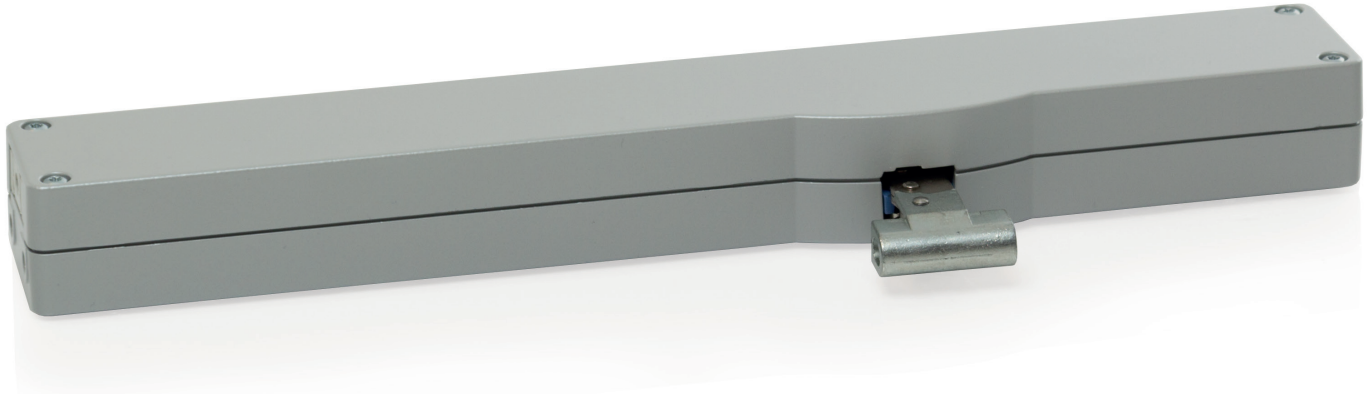
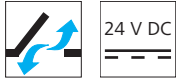

5014068.14001

Find out about permission details from your D+H Partner

Performance features

- » For façade windows, roof windows and ventilation flaps in conservatories
- » With motor electronics controlled via microprocessor
- » "TMS+" tandem safety function for operating 2 drives on one sash
- » Option of chain stroke programming via magnet
- » Reprogrammed opening stroke is transmitted to the tandem drive
- » Simple connection via plug connector
- » Programmable drive functions and different drive parameters
- » Running speed in CLOSED direction decreases to 5 mm/s (passive closing edge protection)
- » Time-controlled reversing when an obstacle is detected in the CLOSED direction (active closing edge protection)

Potential drive options

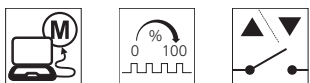

You can find the explanations for the icons on the last page

Pressure load diagram

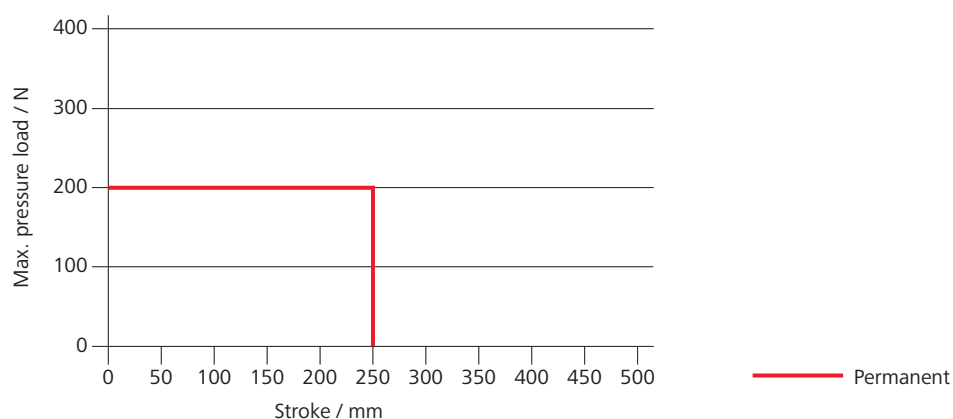

Technical data

Supply	24 V DC / $\pm 20\%$ / 0.35 A
Duty cycle	30 %
Force of pressure	200 N
Tensile force	150 N
Nominal locking force	2000 N
Service life	20000 double strokes *
OPEN running speed	6 mm/s
CLOSED running speed	6 mm/s
Type of protection	IP 30
Emission sound pressure level	$L_pA \leq 70$ dB(A)
Temperature range	0 °C ... +60 °C
Housing	Die-cast zinc
Surface	Powder-coated
Connection	2.5 m PVC-cable
W x H x D	300 x 30 x 47 mm
Weight	1.40 kg

* For vertical use, please consult with D+H Sales !

Dimensions

All specifications in mm

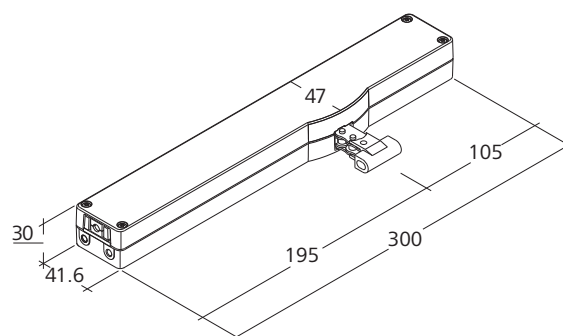

Design

Type	Art. No.	Stroke	Colour	Remark
VCD 203/250 (SR)	25.150.05	250 mm	Silver (~ RAL 9006)	
VCD 203/250 (BK)	25.150.07	250 mm	Black (~ RAL 9005)	
VCD 203/250 (WH)	25.150.06	250 mm	White (~ RAL 9016)	
VCD 203-PLP	25.150.00			Variable equipment possible

Brackets are not included and have to be ordered separately.



HS "High-Speed"

In the case of SHEV, the high-speed function is used for reliably reaching the defined end position in 60 s. In daily ventilation mode, the drive runs quietly and quickly, as usual.



Function programming

Option for customised configuring of drive parameters (e.g. stroke) via software and associated service tools for drives equipped with PLP, BSY or BSY+ electronics.



BRV signal

Acknowledgement from the drive, via a control cable, to confirm that it has been completely extended or retracted. When used with the AT 41 and ERM 44 modules, this signal is sent to the central building control system, the modules themselves, or to the lock drive. The BRV signal is not isolated.



ACB (Advanced Communication Bus)

Enables direct bus communication between the controller and the drive for, for example, control with perfect positioning or drive feedback. Communication is via the open source Modbus protocol, and it enables the drive to be combined with an ACB-capable control panel or enables it to be directly connected to higher-level controllers such as a building management system.



BSY+ (synchronisation of drives)

In addition to providing the same synchronisation function as BSY, BSY+ enables different components in the window to communicate with each other. For example, the chain drives, during synchronous operation, or the window and lock drives (e.g. FRA 11 BSY+ or VLD-BSY+).



SGI signal (position reporting)

In combination with the D+H servo plug-in unit SE 622, the drives can be controlled with perfect positioning.



SKS (closing edge protection)

Drive option, which enables an anti-trap strip or presence detector to be connected directly to the drive (terminal resistor 5.6 kΩ).



Audible signal (corresponding to protection class)

AS2 corresponding to "Protection class 2" in accordance with ZVEI risk assessment through an audible warning signal in the "CLOSED" running direction. AS3 corresponding to "Protection class 3" in accordance with ZVEI risk assessment, in addition to AS2, stops the drive for 11 s with a remaining stroke of 28 mm.



End position message (OPEN / CLOSED)

Drive feedback via an integrated isolated switching contact. This happens if the chain / rack and pinion has moved completely out or in.



Mechanical adjustment

Drive option for adjusting the overall length or design (e.g.: centred chain outlet).



SBD side bow chain

Drive chain with rigid backing, bends in the direction of the hinge. Drive is fixed in place (not rotatable).



SBU side bow chain

Drive chain with rigid backing, bends in the direction of the hinge. Drive is fixed in place (not rotatable).