

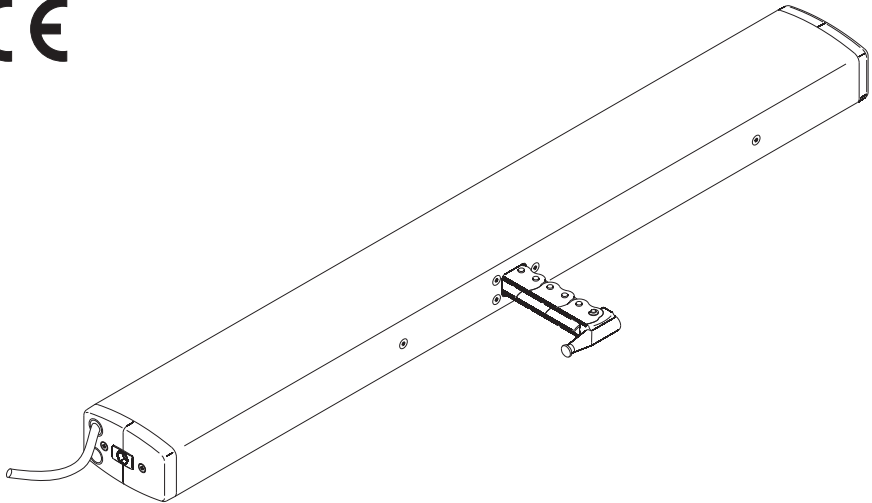

CDP 1500-BSY+ instructions



Please order bracket sets separately



G 513003



Intended use

- Chain drive for electric opening and closing of heavy windows and roof area
- Operating voltage 24 V DC
- Useable for smoke ventilation, D+H Euro-SHEV according to DIN EN 12101-2 as well as daily natural ventilation
- Only for inside mounting

Safety notes

Operating voltage 24 V DC!

Do not connect directly to the mains supply!

- Connection has to be carried out only by an authorized electrical specialist
- Danger of violent pressure in handaccessible area
- Keep away People from the operating area of the drive
- Keep away children from the control
- Observe pressure load diagram of the chain!
- Use only in dry rooms
- Only for inside mounting.
- Use rain detector with danger of rain (e.g. at domelights or roof windows)
- Just use unchanged original D+H parts
- Observe mounting instructions of bracket set!

Observe enclosed red safety slip!

Functional description

A synchron-group (CDP-BSY+) can be count up to 8 drives, which communicate by a bus. Each drive has it's own adress. This adress is configurable with software SCS.

The last drive of a synchron-group is the master, which controls the other drives, the slaves. Different forces between the drives of a group will be balanced with intelligent force- and position control. In case of malfunction respective cutoff of a drive or a position difference ≥ 30 mm, all drives will shut down from the master-drive.

Extent of supply

Drive unit with 2,5 m silicone cable. Dependent on the type of window, different bracket sets are available separately.

Performance features

- Microprocessor controlled synchro electronics BSY + for a precise synchronous run of up to 4 drives
- Individually programmable (via software SCS)
- SHEV-high speed function (fast-running feature in OPEN-direction)
- Protection system for the main closing edge
- Locking relief after closing
- Especially quiet motor running in ventilation mode
- Symmetrical chain outlet
- Connection via pin-and-socket connector
- Optimal with "-AS2" = protection class 2 and "-AS3" as well as "-LS" = protection class 3

Pressure load diagram

Observe maximum pressure load of the chain!
Maximum pressure load of the chain is not automatically identical with maximum pressure force of the drive!

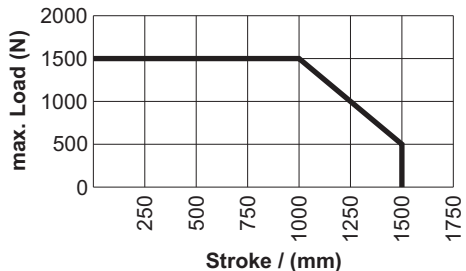

Trouble shooting

Visual inspection:

- Only one master-drive allowed.
- The master has the last address, corresponding to the total number of drives.
- The address is sticked on the drive.
- Slaves are numbered downwards.
- Example: In a group, composed of 3 drives, there is a master 3, a slave 2 and a slave 1 drive.
- Attention: only applies by factory set.
- As soon as the drives were reprogrammed with SCS the addressing might vary from factory set addressing.

Wiring:

- Is the group wired correctly?
- Therefore look connection diagrams.

Null balance:

- It should be null balanced. (Page 8)
- Software SCS or the special magnet MAG 502 is required.

Call D+H Service:

- Drives must be configured.
- Software SCS is required.

Technical data



Type	CDP 800-BSY+	CDP 1000-BSY+	CDP 1500-BSY+
Power supply	24 V DC, ±15 %	24 V DC, ±15 %	24 V DC, ±15 %
Nominal current	3 A	3,3 A	4 A
Nominal force	800 N	1000 N	1500 N
Nominal locking force	1500 N		
Lifetime ***	>10 000 double strokes		
Reliability	Re = 400		
Duty cycle	30 % (With cycle time 10 minutes)		
Housing	Aluminium, PC/ABS (end covers)		
Ingress protection	IP 32		
Temperature range	-5 ... +75 °C		
Fire stability	30 min / 300 °C		
Nominal stroke length *, **	See type plate		
Additional functions *	Closing edge protection activated (3 stroke repetitions), locking relief activated (0,3 mm)		

* Programmable with software SCS
 ** 1000 mm max. according to VdS 2580
 *** (500 mm) according to VdS 2580

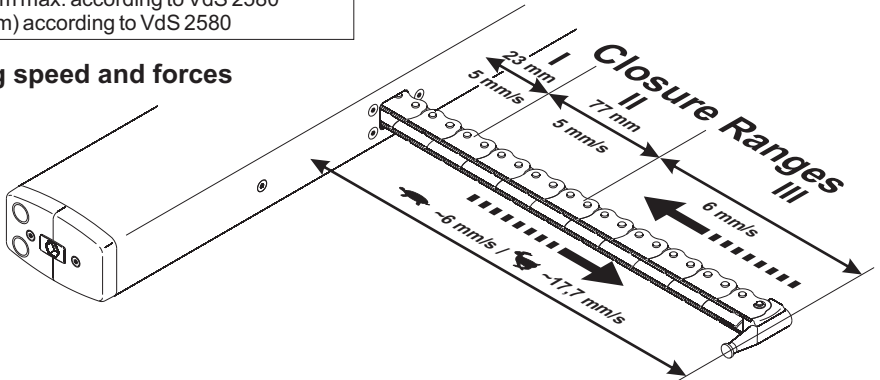
Running speed and forces



Forces	CDP 800	CDP 1000	CDP 1500
OPEN	800 N	1000 N	1500 N
CR III	800 N	1000 N	1000 N
CR II	800 N	1000 N	1000 N
CR I	500 N	500 N	500 N

Normal operation = 
 SHEV- fast running = 
 All forces
 + approx. 20 % switch-off reserve (temporary)

Closing edge protection

In the "CLOSE" direction the drive has an active protection for the main closing edge. If there is an overload in the closing range 3 and 2, the drive runs "OPEN" for 10 seconds, then "CLOSE" again. If after three attempts closing is not possible, the drive remains in this position.

In addition, the drive is equipped with passive protection. The closing speed in closing range 2 and 1 is reduced to 5 mm/s.



There are still substantial forces that pose a risk to life and limb. Significantly greater forces can be exerted at the secondary closing edges. Danger of crushing hands and fingers!

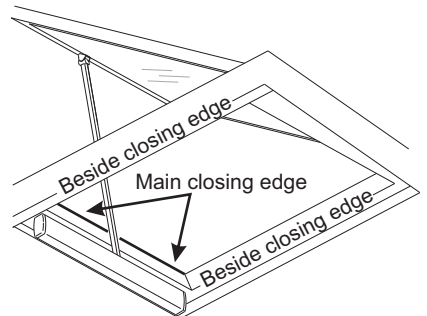

Emergency control / Zeroing

Emergency control (only synchronous group)

BSY+ synchronous control regulates and monitors the difference in position between the drives (max. 30 mm). In the event of an error, all drives are stopped. Before the decision is made to run the drives in auxiliary mode, the cabling should be checked. A short circuit, a reversed phase sequence or an interruption of the bus line will cause the drives to stop or not start up.

When running the drives in auxiliary mode, only the drive in the synchronous group to which the magnet is held is driven. The running direction is determined by the activation direction.

Danger!

Strain on glass can cause the glass to break.

Cordon off the danger area.

Take personal safety precautions.

A second person must be able to interrupt the drive voltage at any time.

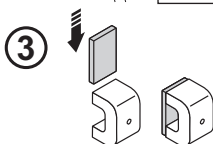
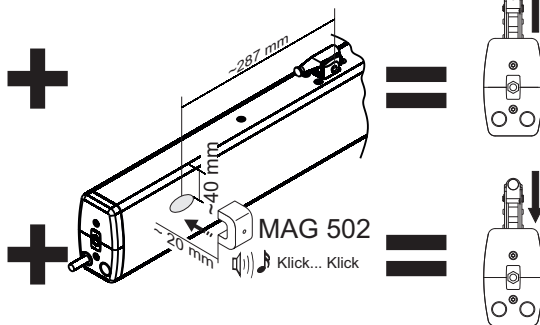
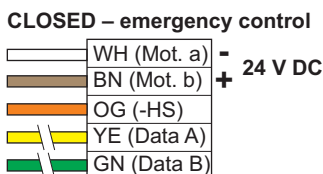
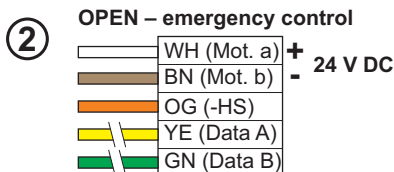
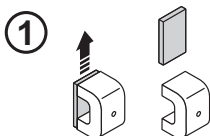

Zeroing

If repeat zeroing of a drive is necessary for installation reasons (chain is driven out > 23 mm in closed position) or for servicing:

Travel the drive to closed position. Wait until the drive has driven completely closed.

Perform zeroing on the drive using the MAG 502 magnet. The magnet gives the drive a second CLOSE command and performs zeroing in the event of an overload cut-off. This is confirmed by the drive quietly humming. Each drive of the set must be individually zeroed in a synchronous group.

Mounting informations

The drive will be full configured by factory. The drives must be reconfigured in case of alterations (e.g. removing of drives from existing set or integrating a new drive) with SCS.

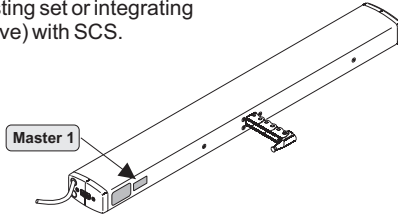

Mount the drives mechanical stress-free. With that, a better load distribution is ensured on all the drives.

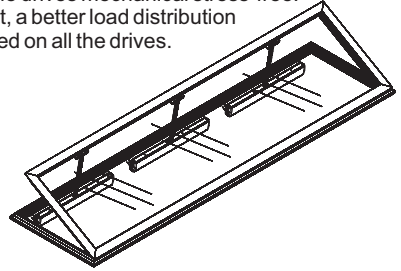

At vertical active pulling application (e.g. for a skylight) the forces must be rearranged by software SCS.

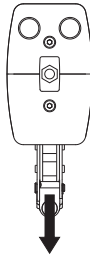

If after mounting the measure x is as 23 mm or bigger, null balance with software SCS or special magnet MAG 502 is necessary. Closure Ranges will shift in relation to new zero point.

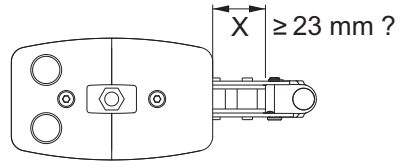

Maintenance and cleaning

Maintenance work is only allowed when the device is in a de-energized condition! Inspection and maintenance has to be carried out according to D+H maintenance notes. Only original D+H spare parts may be used. Repair is to be carried out exclusively by D+H. Wipe away debris or contamination with a dry, soft cloth. Do not use cleaning agents or solvents.

Guarantee

You will get 2 years guarantee for all D+H products from date of verified handing over of the system up to maximal 3 years after date of delivery, when mounting and starting has been carried out by an authorized D+H-distributor. D+H guarantee is expired, with connection of D+H components with external systems or with mixing of D+H products with parts of other manufacturers.

Declaration of Conformity

We declare under our sole responsibility that the product described under "Technical Data" is in conformity with the following directives:

2014/30/EU, 2014/35/EU

Technical file at:
D+H Mechatronic AG, D-22949 Ammersbek

Dirk Dingfelder
Member of the Board
14.03.2017

Maik Schmees
Authorized signatory, Technical Director

Disposal

Electrical devices, accessories, batteries and packaging should be sorted for environmental-friendly recycling. Do not dispose electrical devices and batteries into household waste!

Only for EC countries:
According to the European Guideline 2012/19/EU for waste electrical and electronic equipment and its implementation into national right, electrical devices that are no longer usable must be collected separately and disposed of in an environmentally correct manner.



Connection

Cable mounting

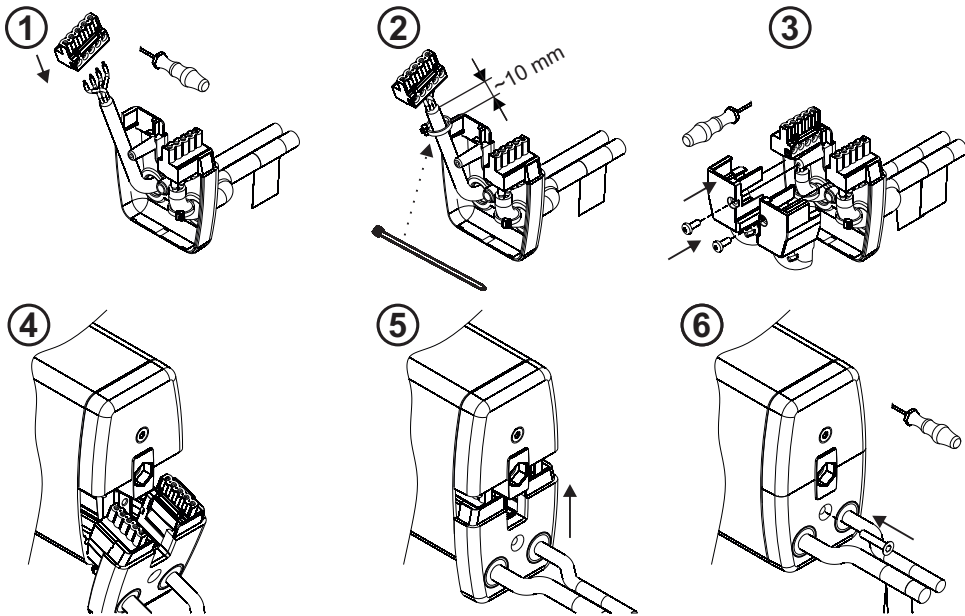

Cable dismounting

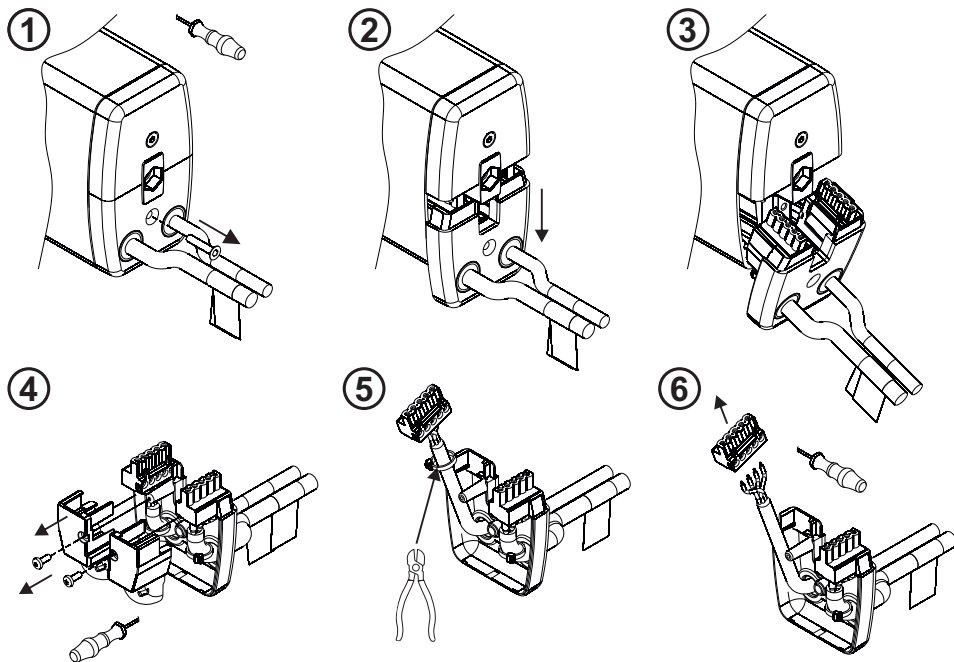

Connection

Pin Assignment

Standard

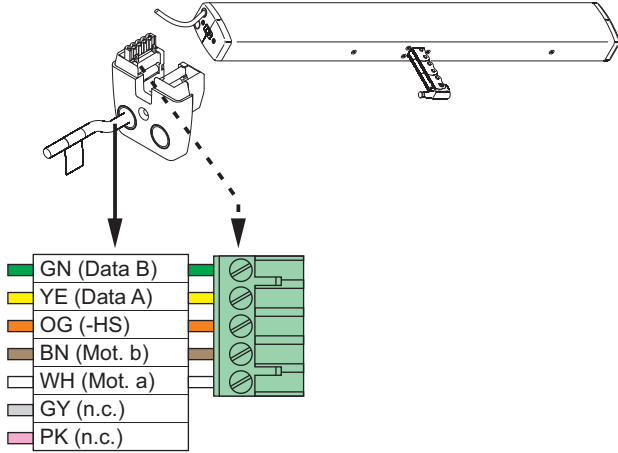

(GN) green
 (YE) yellow
 (BU) blue
 (BN) brown
 (BK) black
 (WH) white
 (PK) pink
 (GY) grey

Option -SGI-SKS

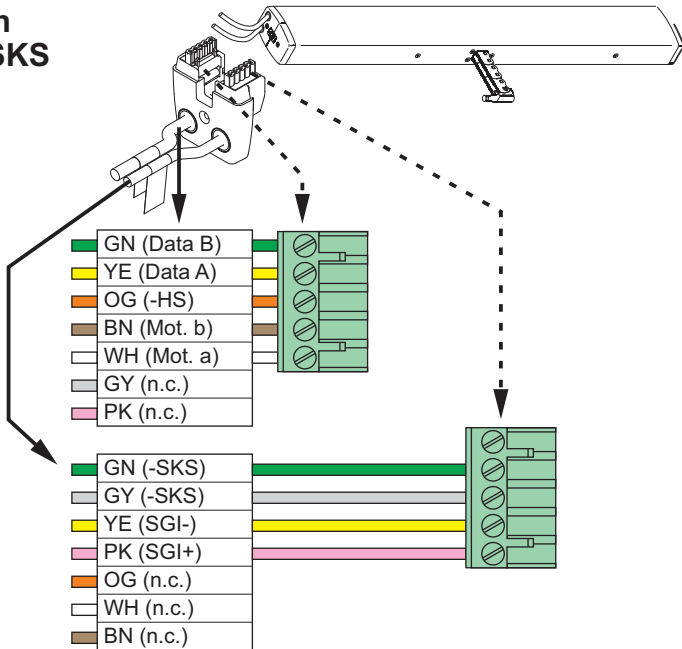

Connection

Pin Assignment

Option -SA-SZ

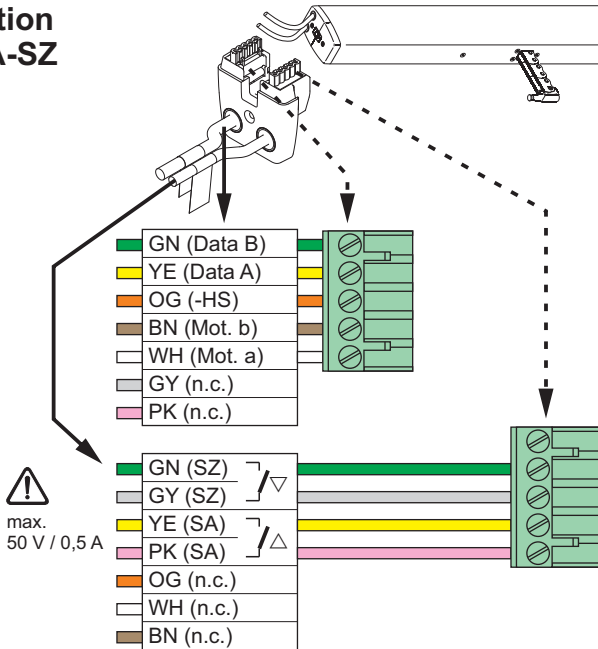

Option -SGI-SKS-SA-SZ

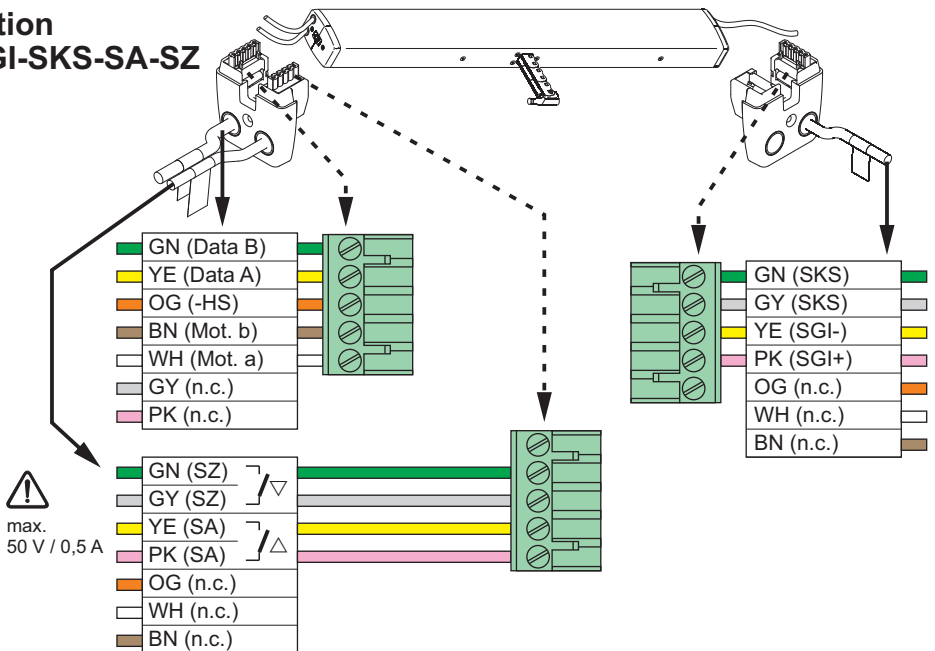

Connection

Pin Assignment

Option -DS

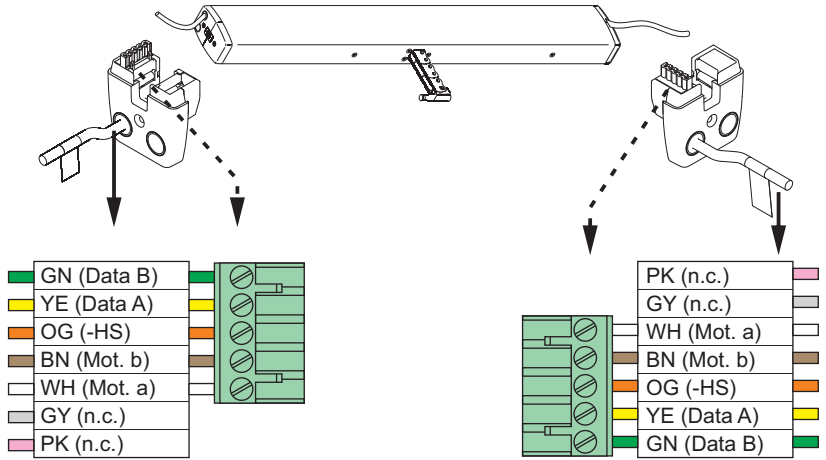

Max. 1x Standard + 1x DS

Connection

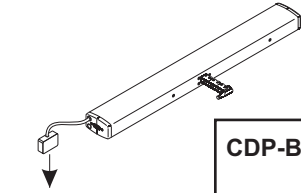

to control panel

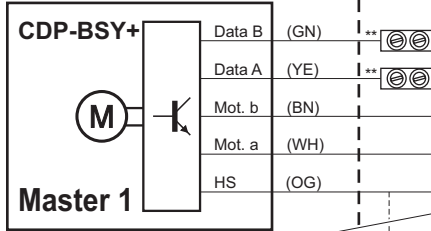

Junction box

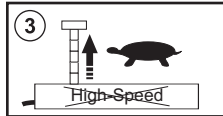
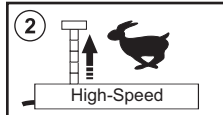
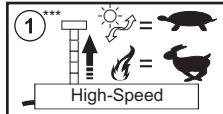
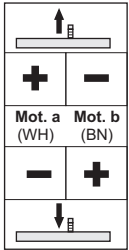
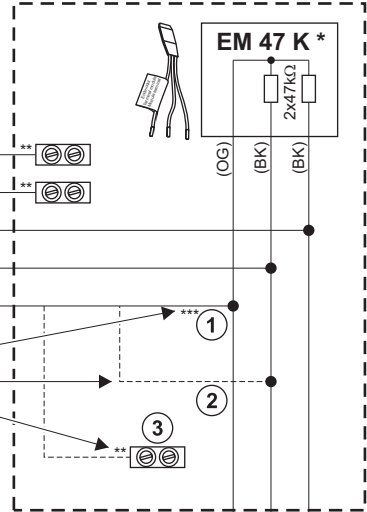

Normal mode

SHEV- fast running

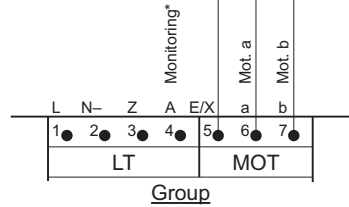

* Not in case of GVL 8x0x-E/ -K/ -M

** protect against short circuit

*** In case of connection to D+H SHEV control panels with E/HS line monitoring

**** Cable acc. to D+H table for layout of cables (see instructions for use of control panel)

Connection

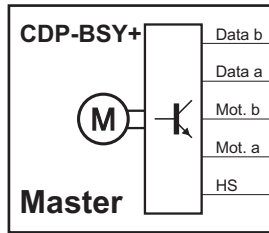
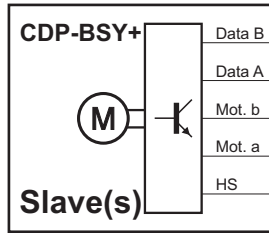
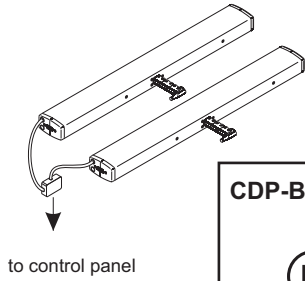

Junction box

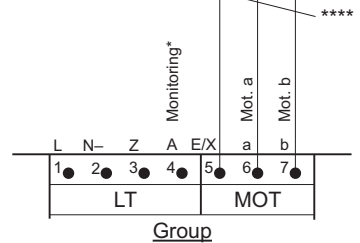
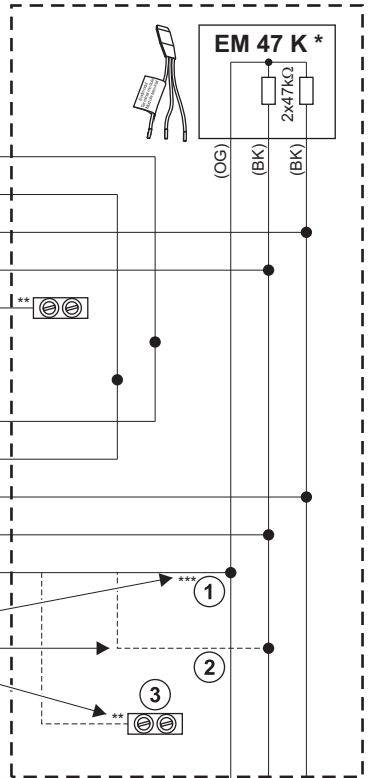

- (WH) white
- (BN) brown
- (OG) orange
- (YE) yellow
- (GN) green
- (PK) pink
- (GY) grey

Dimensions

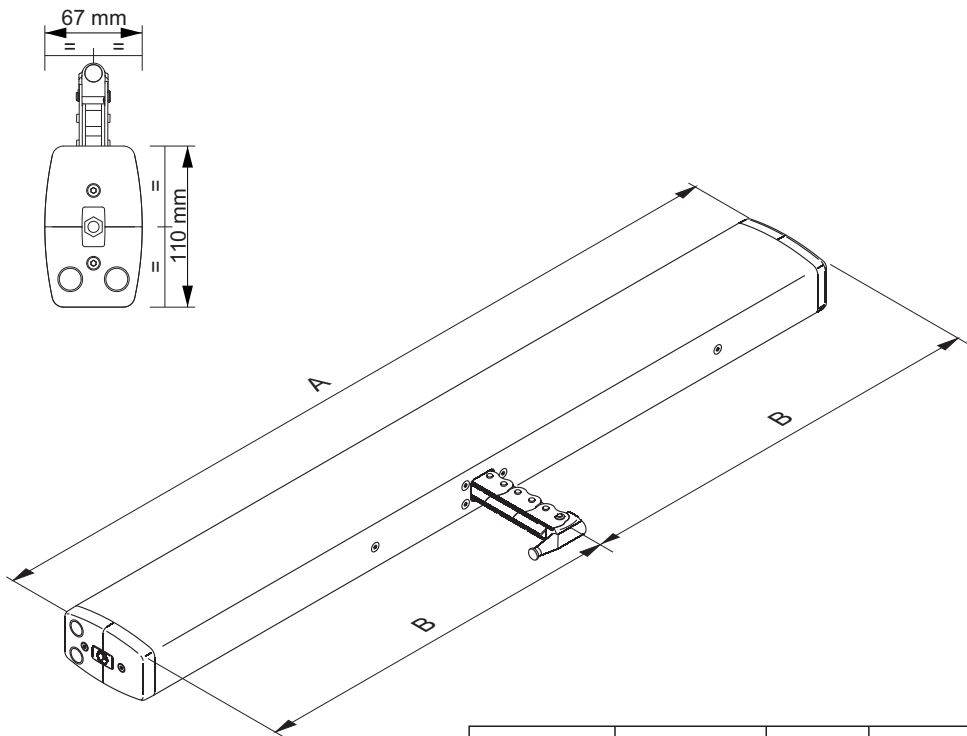

Stroke	Weight	A	B
600 mm	7,5 kg	702 mm	351 mm
800 mm	8,3 kg	807 mm	403,5 mm
1000 mm	9,2 kg	934 mm	467 mm
1200 mm	10,2 kg	1086 mm	543 mm
1500 mm	11,4 kg	1264 mm	632 mm



Dyer Environmental Controls Ltd
 Unit 10 Lawnhurst Trading Estate, Cheadle Heath,
 Stockport SK3 0SD

Tel: +44 (0)161 491 4840
 E-Mail: enquiry@dyerenvironmental.co.uk

www.dyerenvironmental.co.uk