



# CDC-0252-1-ACB instructions



CE

Standard version "-R"

Mirrored version (option "-L")

Please order bracket sets separately



## WARNING

Read all safety warnings, instructions, illustrations and specifications provided with this product. Failure to follow all instructions listed below may result in electric shock, fire and/or serious injury. Save all warnings and instructions for future reference.

## Safety notes

### Safety extra low voltage 24 V DC!

Do not connect directly to the mains supply!

- Connection must be carried out by a certified electrical technician
- Danger of crushing hands and fingers!
- Keep people away from the operating area of the drive
- Keep children away from the control
- Observe pressure load diagram of the chain
- Use only in dry rooms
- Suitable for indoor mounting only. Use rain detector in locations if there is a risk of rain
- Use unmodified original D+H parts only
- Observe mounting instructions of bracket set!

**Observe enclosed red safety note!**

## Scope of supply

Drive unit with 2.5 m silicone cable.  
Depending on the type of window, different bracket sets are available separately.

## Chain type



The mounting instructions for the bracket set must be observed before mounting. Always observe and comply with the information in the mounting instructions.

Attention with side bow chains SBD and SBU

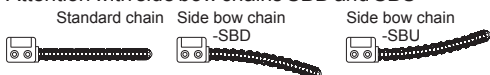

## Intended use

- Chain drive for electric opening and closing of windows and flaps in the facade and roof area
- Operating voltage 24 V DC
- Useable for smoke ventilation as well as daily natural ventilation
- Suitable for indoor mounting only

## Features

- ACB (Advanced Communication Bus) bus interface with ModBus protocol for the connection to compatible D+H control panels or direct integration into building management systems, for example
- BSY+ electronics for reliable and accurate synchronous operation of up to 8 drives
- Individually programmable via software SCS
- Outstanding quiet performance thanks to acoustic decoupling of the drive components and reduced motor speed in ventilation mode
- SHEV-high speed function (fast-running feature in case of an alarm)
- Protection system for the main closing edge
- Rated voltage and Bus-signals loopable for max. 3 drives
- Connection possible from both sides
- The force can be increased at the factory up to 400 N (nominal current 1 A) in the seal area
- Relief of pressure on window gasket after closing
- Direct connection of additional closing edge protection at the drive possible (SKS option)

## Pressure load diagram

Observe maximum pressure load of the chain!  
Maximum pressure load of chain is not automatically identical with maximum pressure force of the drive!

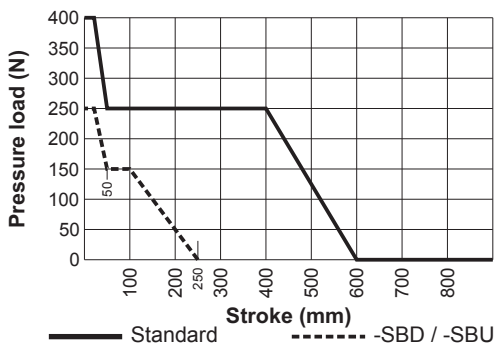

# Technical Data

Type	CDC-0252-0350-1-ACB	CDC-0252-0500-1-ACB	CDC-0252-0600-1-ACB	CDC-0252-0800-1-ACB
Power supply	24 V DC / ± 15 %			
Nominal force	250 N**			
Nominal current	0,6 A	0,8 A		1,0 A
Nominal stroke length*	350 mm ± 2 %	500 mm ± 2 %	600 mm ± 2 %	800mm ± 2 %
Running speed: ventilation (SHEV high-speed function)*				
O1, O2	6,7 mm/s (9,4 mm/s)	6,7 mm/s (13,6 mm/s)		6,7 mm/s (15,0 mm/s)
O3	6,7 mm/s (6,7 mm/s)	6,7 mm/s (6,7 mm/s)		6,7 mm/s (6,7 mm/s)
C3	5 mm/s (9,4 mm/s)	6,7 mm/s (13,6 mm/s)		6,7 mm/s (15,0 mm/s)
C2, C1	5 mm/s (5 mm/s)	5 mm/s (5 mm/s)		5 mm/s (5 mm/s)
Nominal locking force	approx. 1500 N			
Service life	>10.000 double strokes			
Duty cycle	30 % S6 (EN 60034-1)			
Housing	Aluminium powdercoated (~ RAL 9006)			
Ingress protection	IP 32			
Temp. range	-5 ... +75 °C			
Fire stability	30 min / 300 °C			
Ambient humidity	≤ 90 %, not condensing			
Emission sound pressure level	LpA = 35 dB(A)			
Additional functions*	Closing edge protection = activated (3 repetitions of stroke); Locking relief = activated (retraction lift max. 0,2 mm)			

## Opening and Closing Ranges

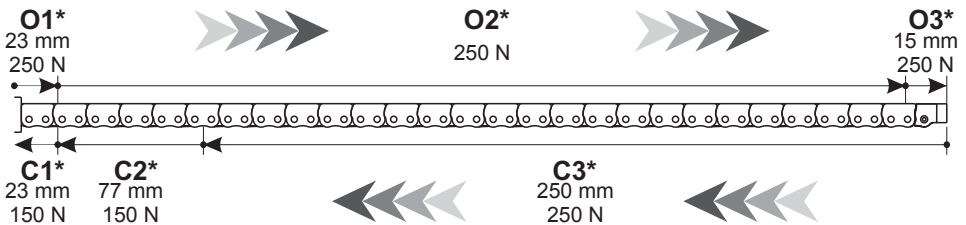

\* Programmable with software SCS \*\* + approx. 20 % switch-off reserve (temporary)

## Closing edge protection

In the "CLOSE" direction the drive has an active protection for the main closing edge. If there is an overload in the closing ranges C3 and C2, the drive runs "OPEN" for 10 seconds, then "CLOSE" again. If closing is not possible after three attempts, the drive remains in this position.

In addition, the drive is equipped with passive protection. The closing speed in closing range C2 and C1 is reduced to 5 mm/s.



Significantly greater forces can be exerted at the secondary closing edges. Danger of crushing hands and fingers!

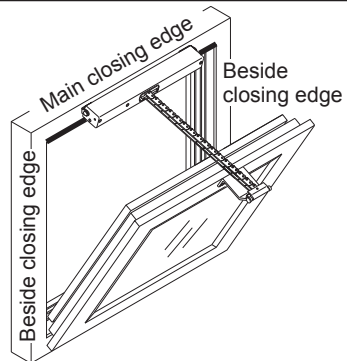

## Mounting information

- The drive set is fully configured ex factory. The drives must be reconfigured using SCS in the event of changes to the ex-factory configuration (e.g. when removing a drive from existing set or integrating a new drive).
- Mount the drives whilst under zero stress. With that, an even load distribution is provided by all the drive chains.
- At vertical active pulling application (e.g. for a skylight) the forces must be rearranged by software SCS.

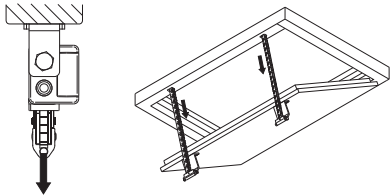

- If after mounting, the distance X is greater than 23 mm, null balance with software SCS is necessary. Closure Ranges will shift in relation to new zero point.

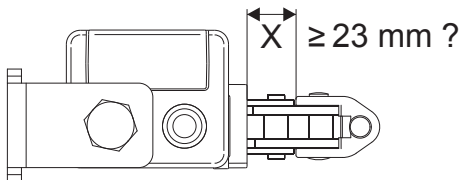

## Minimum sash height/ -width

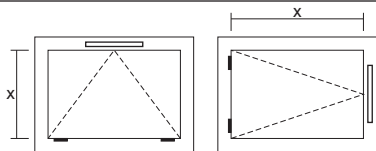

The details apply to a **non-rotational installation of the drive!**  
(Window inwards opening)

### Standard chain:

Minimum size (mm) = Stroke (mm) x 3.9  
Maximum stroke bottom-hung vent: 1300 mm  
Maximum stroke side-hung vent: 800 mm

### Side bow chain:

Minimum size (mm) = Stroke (mm) x 1,6  
Maximum stroke bottom-hung vent: 800 mm  
Maximum stroke side-hung vent: 350 mm

## Functional description

### ACB bus interface

ACB is used for secure communication between the drive and compatible D+H control systems. It enables activation, diagnostics and configuration with perfect position, directly from the control panel. In this process, all status messages, such as the OPEN and CLOSED signals, opening stroke and drive errors, are transmitted to the control panel.

### BSY+ synchronised electronics:

A synchronous group can contain up to 8 drives, which communicate via bus. Each drive has its own address, configurable with SCS.

The last drive of a synchronous group is the master, which controls the other drives, the slaves. Differences in forces between the drives of a group are balanced by means of intelligent force and position control. In the event that a drive malfunctions, all the drives are automatically cut off.

## Troubleshooting

### Visual inspection:

Only one master drive is allowed.

The master always has the last address of all the drives; this can be found on a sticker attached to the drive. Slaves are numbered downwards from the master, so that in a group of three drives, for example, the master is no. 3, with a slave 2 and slave 1 drive. Please note that this only applies in the ex-factory configuration. As soon as the drives are reconfigured with SCS, the ex-factory addressing no longer applies.

### Wiring:

Is the drive or drive group wired properly?  
See connection plans.

### Diagnostics with SCS software:

The SCS software and a BSY+ interface is required for further troubleshooting or configuration.

## Maintenance and cleaning

Maintenance work is only allowed when the device is in a de-energized condition! Inspection and maintenance has to be carried out according to D+H maintenance notes. Only original D+H spare parts may be used. Repair is to be carried out exclusively by D+H. Wipe away debris or contamination with a dry, soft cloth. Do not use cleaning agents or solvents.

## Guarantee

You will get 2 years guarantee for all D+H products from date of verified handing over of the system up to maximal 3 years after date of delivery, when mounting and starting has been carried out by an authorized D+H-distributor. D+H guarantee is expired, with connection of D+H components with external systems or with mixing of D+H products with parts of other manufacturers.

## Declaration of Conformity

We declare under our sole responsibility that the product described under "Technical Data" is in conformity with the following directives:

2014/30/EU, 2014/35/EU

Technical file at:  
D+H Mechatronic AG, D-22949 Ammersbek

Dirk Dingfelder  
Member of the Board  
11.08.2016

Maik Schmees  
Authorized signatory, Technical Director

## Disposal

Electrical devices, accessories, batteries and packaging should be sorted for environmental-friendly recycling. Do not dispose electrical devices and batteries into household waste!

Only for EC countries:

According to the European Guideline 2012/19/EU for waste electrical and electronic equipment and its implementation into national right, electrical devices that are no longer usable must be collected separately and disposed of in an environmentally correct manner.

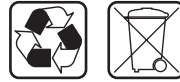

## Dimensions

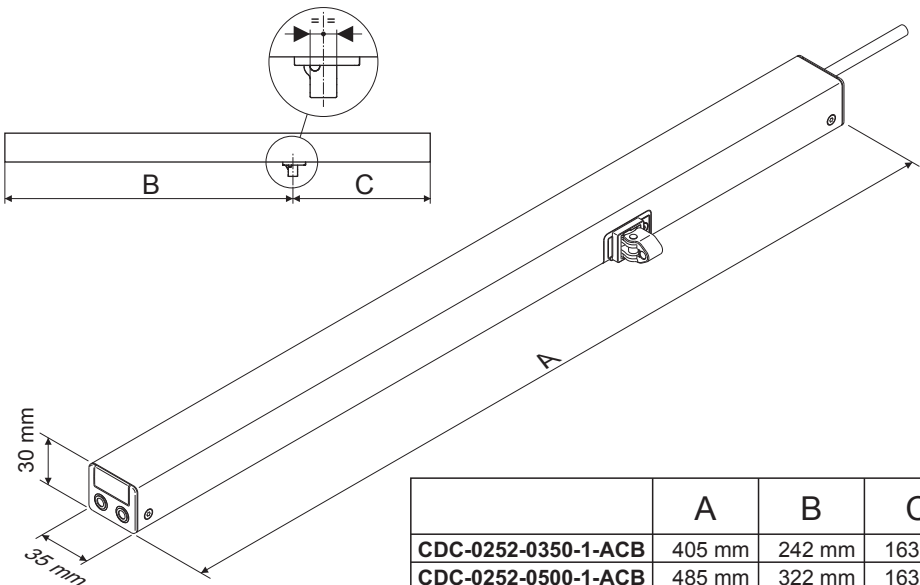

	A	B	C
<b>CDC-0252-0350-1-ACB</b>	405 mm	242 mm	163 mm
<b>CDC-0252-0500-1-ACB</b>	485 mm	322 mm	163 mm
<b>CDC-0252-0600-1-ACB</b>	530 mm	367 mm	163 mm
<b>CDC-0252-0800-1-ACB</b>	635 mm	472 mm	163 mm

# Connection



1 drive

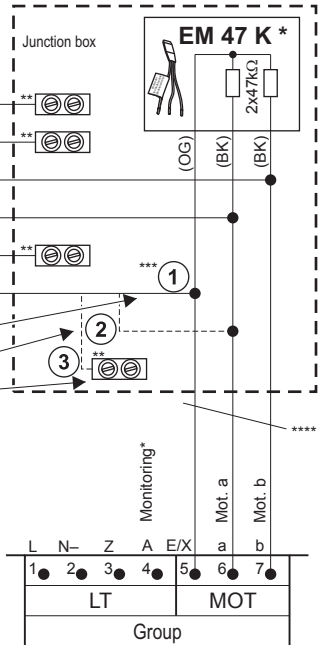
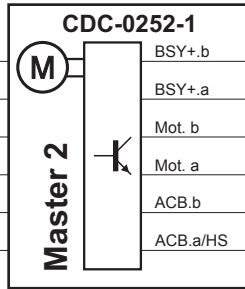
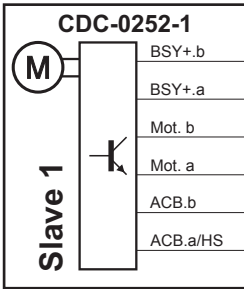
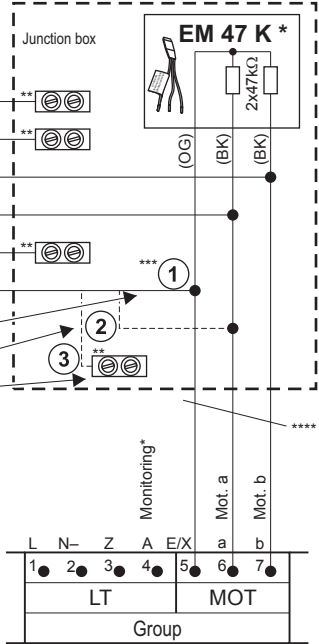
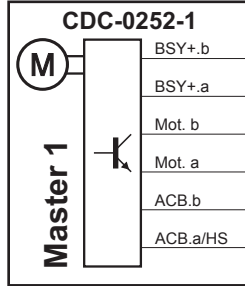
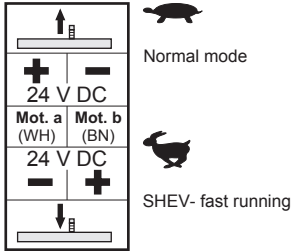
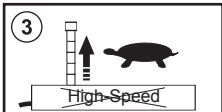
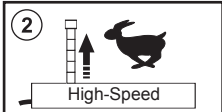
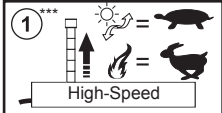

2 up to max. 3 drives looped through

# Connection

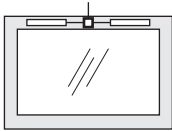

2 drives star-shaped

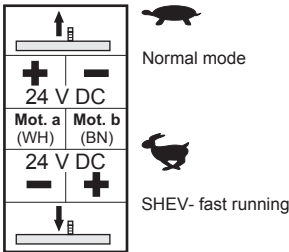
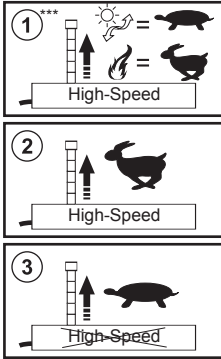

- (WH) white
- (BN) brown
- (OG) orange
- (YE) yellow
- (GN) green
- (PK) pink
- (GY) grey

- \* Not in case of GVL -E/ -K/ -M
- \*\* Protect wire against short circuit
- \*\*\* In case of connection to D+H SHEV control panels with E/HS line monitoring
- \*\*\*\* Cable according to D+H table for layout of cables (See instructions for use of control panel)

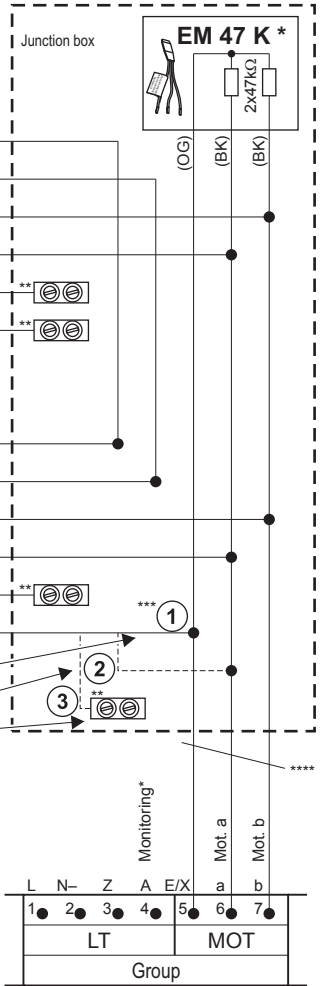
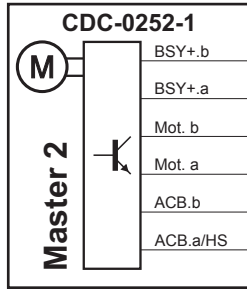
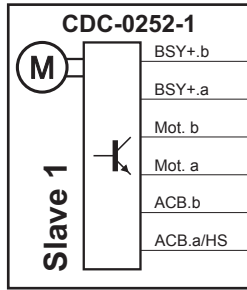

# Connection

## Pin Assignment

Motor side

Chain side

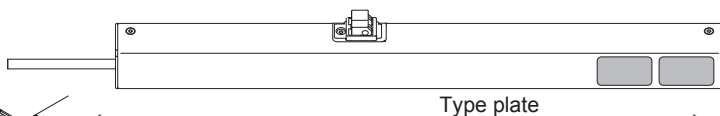

Type plate

6x 0,5 mm<sup>2</sup>  
Ø 7,1 ± 0,5 mm

6x 0,5 mm<sup>2</sup>  
Ø 7,1 ± 0,5 mm

Standard

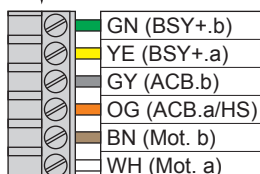
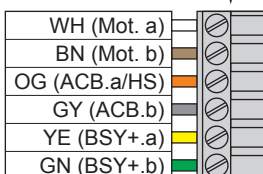

Option  
-SKS

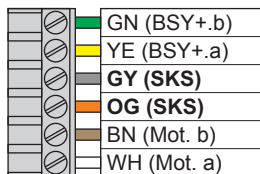
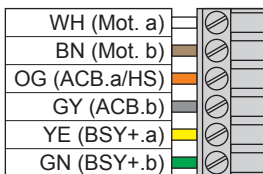

- (WH) white
- (BN) brown
- (OG) orange
- (YE) yellow
- (GN) green
- (PK) pink
- (GY) grey



Dyer Environmental Controls Ltd  
Unit 10 Lawnhurst Trading Estate, Cheadle Heath,  
Stockport SK3 0SD

Tel: +44 (0)161 491 4840  
E-Mail: [enquiry@dyerenvironmental.co.uk](mailto:enquiry@dyerenvironmental.co.uk)

[www.dyerenvironmental.co.uk](http://www.dyerenvironmental.co.uk)