



cycle-works

The Cycle Storage Specialists

Product Guide & Case Studies

Josta 2-tier

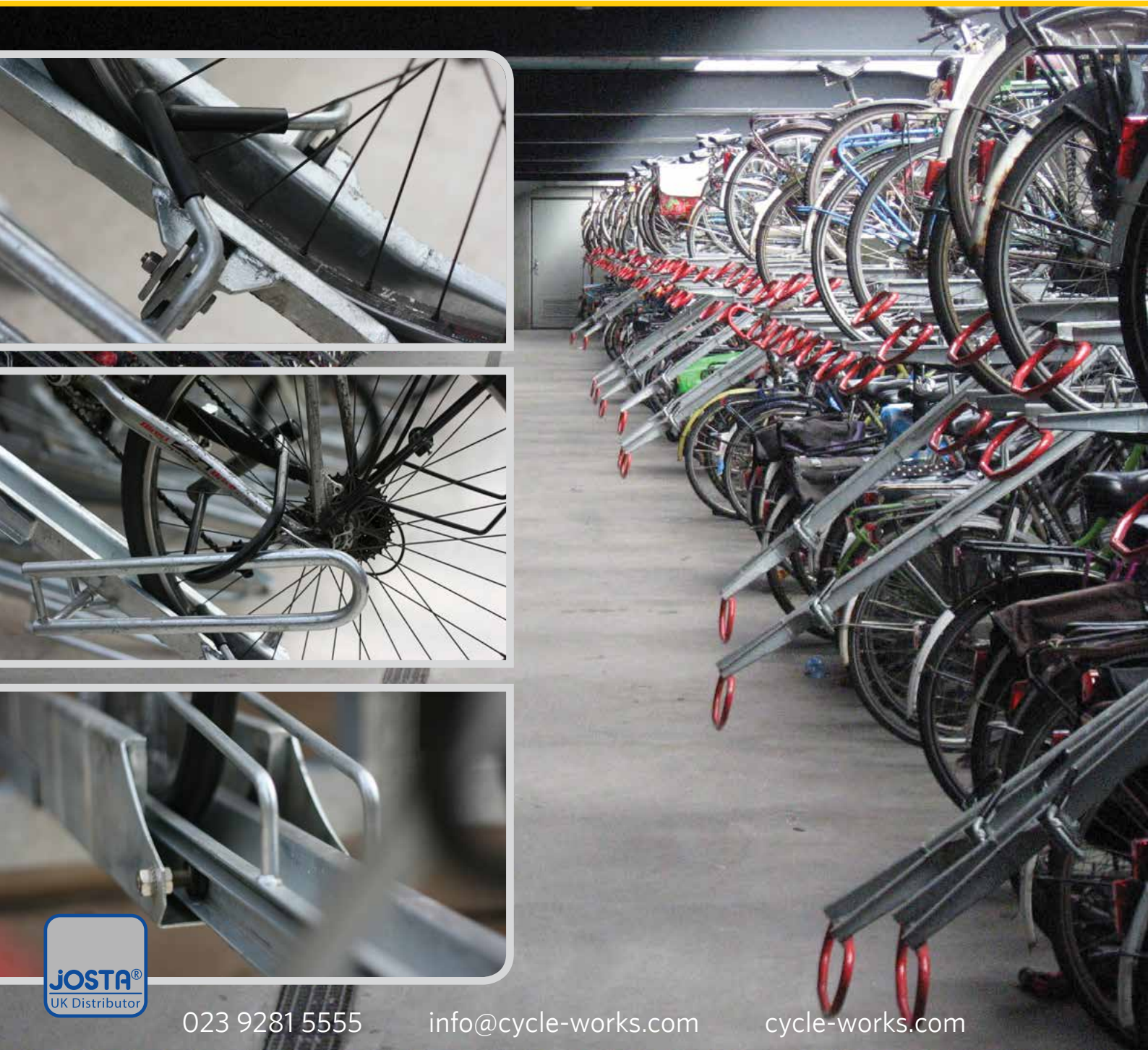

023 9281 5555

info@cycle-works.com

cycle-works.com



cycle-works

The Cycle Storage Specialists

Josta® 2-tier High Capacity Racks



The market leaders in high capacity bicycle racks, offering space efficient and cost-effective cycle storage.

- Double the number of bicycle storage spaces
- Easy and safe to use - with a proven track record in the UK, Europe, Australia and the USA
- Space-efficient
- Flexible and adaptable
- Neat and organised
- Individual racking - one bike per space
- Low maintenance
- Patented gripping system holds bike securely
- Maximises cycle parking spaces and allows more car parking (if required) or creates space for other uses
- The racks can be used to help demonstrate compliance with BREEAM and achieve a high BREEAM rating
- Framework can be coloured in any standard RAL colour (optional extra)

There are many unique features of the Josta® racks. This includes the low, easy to use handles, the clever, patented way the bikes are held on the racks and the general ease of use.

They are also designed for a long, tough life of constant heavy use, with low maintenance. However, the most important factor is always safety, and the Josta® racks are very safe to use. This is a particularly important feature for heavy bikes.



Liverpool Street Station, London

London Liverpool Street Station more than doubled its awkward bike parking in a limited space. By using the Josta® 2-tier capacity was increased from 80 to 189 bike spaces.

Cycle-Works
8-9 Rodney Road
Portsmouth
Hampshire
PO4 8BF

t 02392 815 555
f 02392 815 544
e info@cycle-works.com
w cycle-works.com

Cycle-Works Ltd
Registered in England 3268339



ESi.info





Josta® 2-tier High Capacity Racks

Innovative unique features



Wheel Gripping Mechanism

A special, patented gripping mechanism ensures that the bike cannot roll back and injure the user. As the bike is pushed into the rack, the mechanism gently clamps around the front wheel. As you push the bike up the channel, the front wheel is released and the back wheel is clamped securely into place.

The mechanism is very well designed and fabricated, so that if an extended rack containing a bike should be accidentally dropped, the bike will be securely held in place, causing no harm to user or bike. The Josta® 2-tier rack is the only 2-tier system to offer this type of safety feature.



Movable Security Bar

The Josta® 2-tier rack comes with a movable bar as standard. This security feature is positioned at the rear of the rack in the optimum location to securely lock the rear wheel and bike frame.

When the rack is not in use, the security bar is lowered down, lying parallel to the rack. It is the feature that allows the bike to be easily pushed up the channel without any obstructions for the pedals.



Pivoting Channel

The central channel that holds the bike is built around an extending, pivoting channel. It is this feature that utilises a 'sweet spot' for pivoting, allowing a full rack to be very easily lifted up and pushed back into place.

The strong box section, galvanised mild steel construction and precision engineering all ensure that this product has an extremely long and low maintenance life.

Code for Sustainable Homes

All our lockers, shelters and racks they can be used to help contribute towards gaining your 2 ENE8 Cycle Storage Credits when used in an appropriate situation, under the Code for Sustainable Homes.

[more info](#)

BREEAM

All our lockers, shelters and racks they can be used to help demonstrate compliance with BREEAM and achieve a high BREEAM rating when used in an appropriate situation.

[more info](#)

Cycle-works and its products and services are not affiliated, endorsed or certified by BRE Global or its affiliates. All rights are reserved.

Gas Assisted

Josta® have developed a new 'gas cylinder' model that makes lifting and lowering the racks even easier. The strong gas strut is built into the middle of the top rack, in a unique design. This means there are no moving parts to catch fingers and the whole structure is modern and stylish. 2700mm headroom is needed for G.A. racks.



Cycle-Works
8-9 Rodney Road
Portsmouth
Hampshire
PO4 8BF

t 02392 815 555
f 02392 815 544
e info@cycle-works.com
w cycle-works.com

Cycle-Works Ltd
Registered in England 3268339





Josta® 2-tier High Capacity Racks

The Josta® 2-tier rack is a high capacity double decker bicycle rack.

Josta® is the market leader for high capacity racking systems. Their racks are popular across Europe, the USA and Australia. Many bike stations in Germany, Holland and the US also specify the Josta® rack as standard. Cycle-Works are the UK's exclusive distributor of the Josta® 2-tier rack system and have extensive experience of providing cycle parking including shelters, compounds, racks and bike lockers.

Josta® 2-tier sites range from small open access installations of less than 80 bike spaces (e.g. Surbiton station) to large manned cycle parks of 7000 (e.g. Leiden, NL). They are also increasingly used in the basements of new office blocks and apartments (e.g. The prestigious Foster's Albion Riverside development in Battersea).

Why the Josta® rack is the market leader in high capacity bike parking

This space efficient racking system stores one bike directly above the other. It therefore increases the amount of bicycles parked (or reduces the size of the site) by up to 50%.

The rack is custom made for specific sites to maximize the cycle parking capacity, and can be used in conjunction with other systems.

A special patented gripping mechanism ensures that the bike cannot roll back and injure the user. We find the top racks are usually filled first as users like to store their bike 'out of harm's way'. It is also easier to lock the bike when on the top rack. This usually leaves enough space in the bottom row for users who do not wish to use the top row.

Layout and Space Requirements

This racking system is designed to fit your exact space. It can be used in conjunction with our other cycle parking systems to give the maximum capacity for your site.

Mounting/Installation

A level concrete base is usually required (not screed). This racking system is then installed by our team of experienced installers. Special supports for non-concrete sites with strong level surfaces can be supplied for a small additional charge.

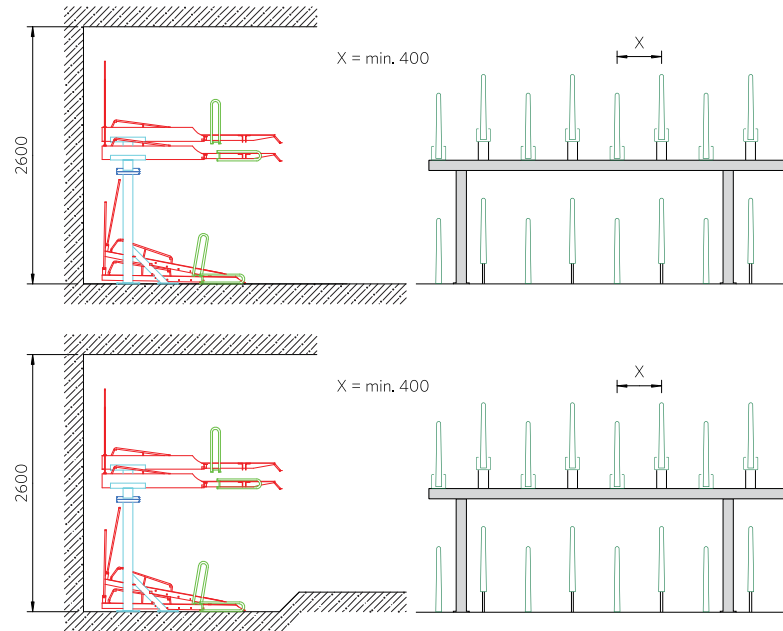

Site Planning

We are happy to give advice or assist you with your site planning. For this, please let us have your draft site plan (DWG or PDF format), clearly marked with all relevant dimensions, obstacles and access ways. Please see the next page for a guide on designing a site yourself.

Please contact us to obtain DWG files of the product layout.

Locking mechanisms and options

A security bar allows the cyclist to lock the bike frame and wheels with their own chain or D-lock. The front wheel and frame can also be locked easily.

Delivery

The current lead time is 6-8 weeks, but larger projects can require more than this. It is really beneficial if Cycle-Works are involved in the site planning as soon as possible.

Material options

These racks are usually galvanised with a red handle on the top racks, the framework can be powder coated in any standard RAL colour.



Josta® 2-tier High Capacity Racks

Site Requirements

- A minimum of 2600mm of clear headroom is required for maximum capacity.
- Leave 300mm to any adjoining side wall to give space for the handlebars.
- The racks are then spaced at a minimum of 400mm centres. We have found 450mm to be a good spacing, giving capacity as well as ensuring ease of use.
- Please allow 2000mm for the rack itself and another 2000mm in front for loading the bike. It is possible to allow 1700mm for loading but we strongly recommend at least 2000mm for optimal operation.
- The racks can also be installed from a central spine. For this option, please leave 2000mm for access on both sides. The 2-sided unit is then 3100mm wide.
- Racks can also be installed at a 45 or 55 degree angle to minimise space.

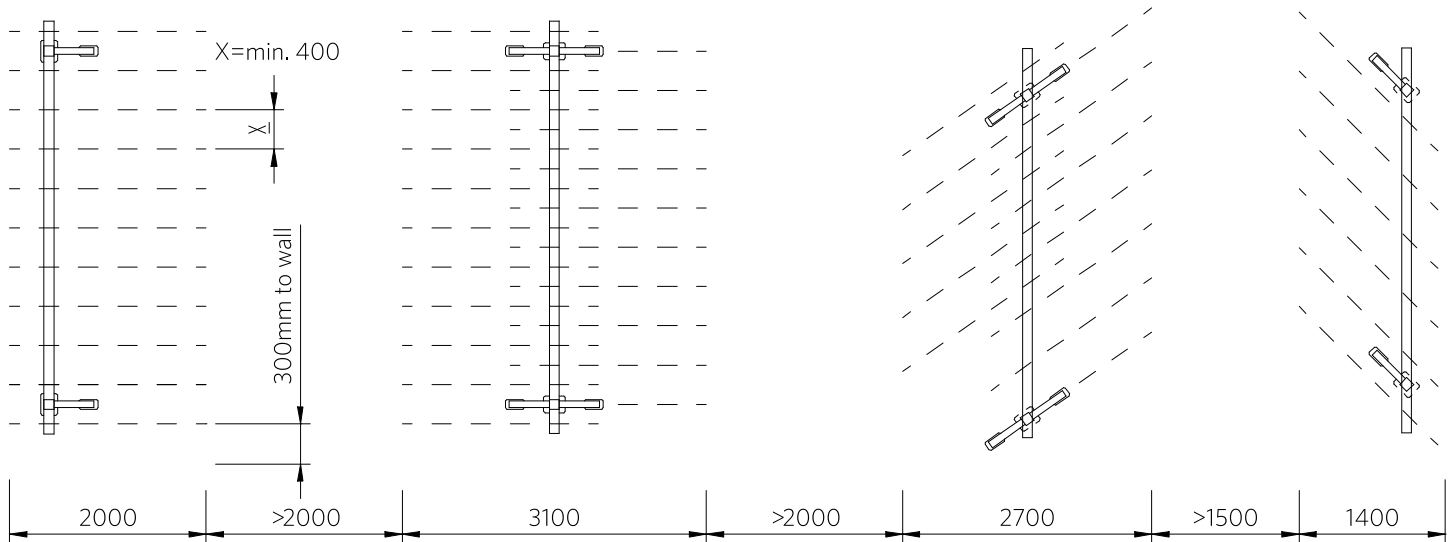
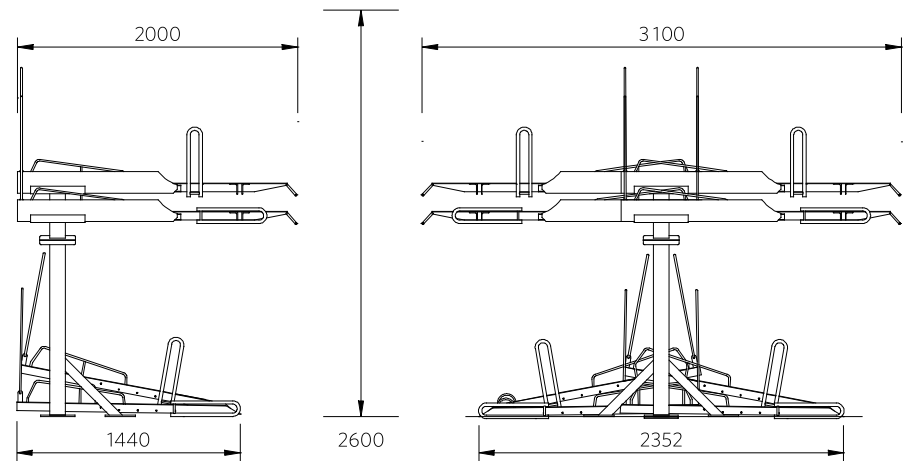
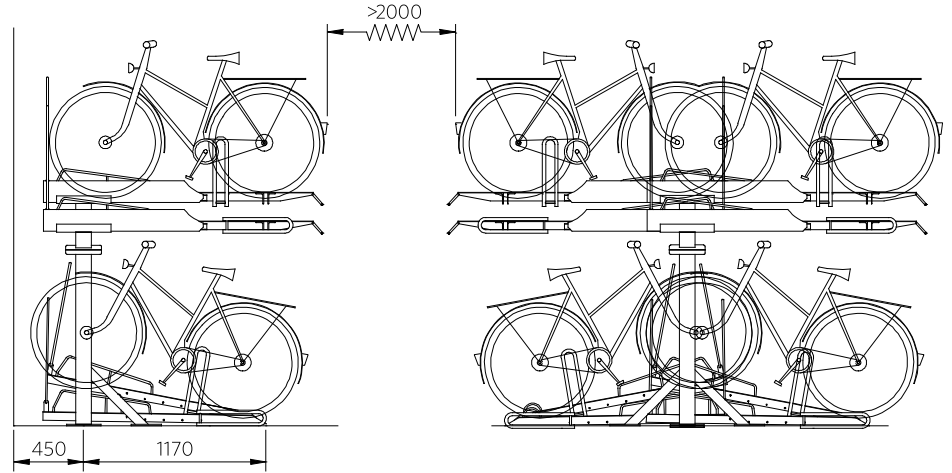



Josta® 2-tier High Capacity Racks

Store and retrieve your bike in four easy steps

Loading your bike on to the upper racks

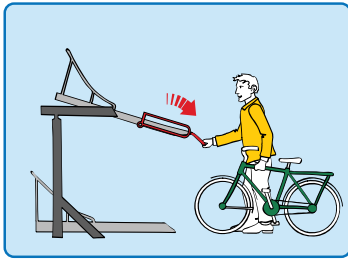

1. Pull down the upper rack.

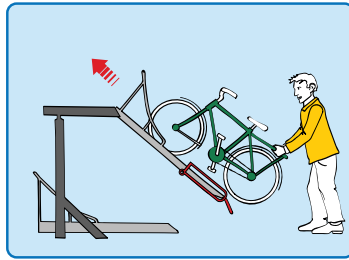

2. Lift the front wheel onto the lowered rack and push forwards.

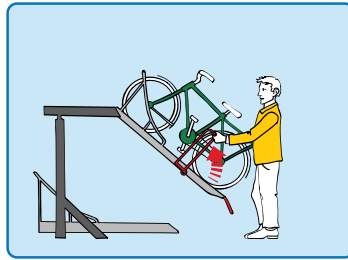

3. Raise the locking bar and lock the bike to it.

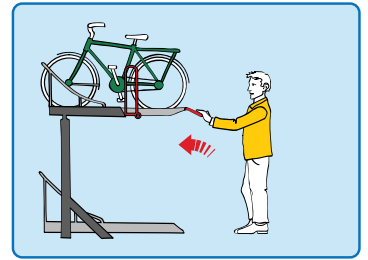

4. Lift the rack back into the horizontal position

Unloading your bike from the upper racks

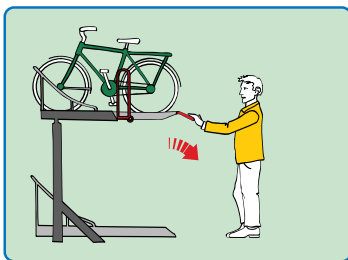

1. Pull down the upper rack, the bike will lower slowly towards you

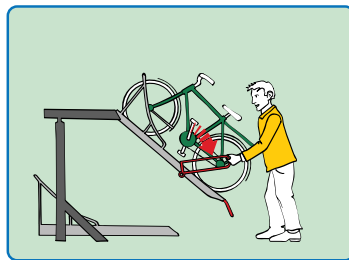

2. Unlock the bike and lower the locking bar

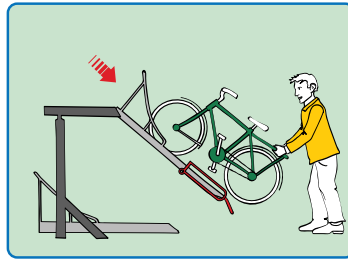

3. Hold the bike and guide backwards towards you

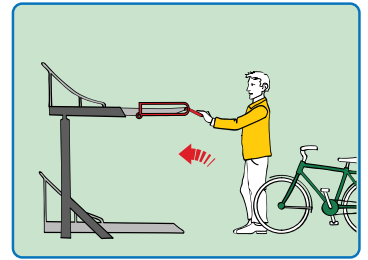

4. Return the upper rack to its original position

Shelters

Cycle-Works can also provide a range of quality shelters and compounds to complement the Josta® 2-tier rack. These can be customised as required.

Shelter height

2700mm recommended
2600mm minimum



[more info](#)

Higher Kennet, East Croydon train station



[more info](#)

Higher Solent, Euston train station



[more info](#)

Medway Shelter, St George's Hospital



[more info](#)

Medway Compound, St George's Hospital



[more info](#)

Berlin Lockable Compound



cycle-works

The Cycle Storage Specialists

cycle-works

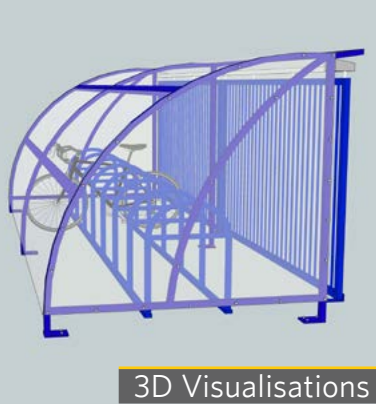

3D Visualisations

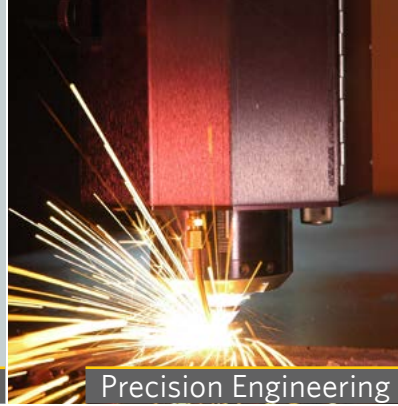

Precision Engineering



Powder Coating



Professional Installation



Commercial / Residential



Healthcare



Rail



Education

About Cycle-Works

Cycling is our passion. We believe that cycling is good for people, good for society and good for the environment. This belief underpins everything we do. We believe that the provision of quality facilities will increase the use and acceptance of the bicycle.

All our employees and associates cycle regularly in diverse disciplines such as commuting, touring and long distance audax rides. We are active in both local and national cycle campaigning.

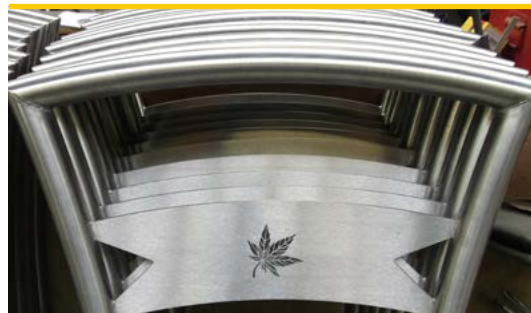

Our Products

- Individual bicycle lockers
- High capacity 2-tier racks
- Open access and lockable shelters
- Wide range of individual racks
- Vertical and horizontal racks



Our Services

- Initial site visits
- Advice on product selection
- Consultation on your plans
- Full delivery and installation
- Aftercare and maintenance



cycle-works

The Cycle Storage Specialists
cycle-works.com • 02392 815 555



cycle-works

The Cycle Storage Specialists

cycle-works.com • 02392 815 555

Case Study

Chester Station doubles up its parking

J Murphy & Sons teamed up with Cycle-Works to provide a major upgrade of the cycling facilities at Chester Station.

For this site, Cycle-Works and J Murphy worked closely together to provide the maximum amount of cycle parking in the available space.

As a result, Cycle-Works installed 66 high capacity Josta 2-tier racks under three Higher Kennet shelters, in both single and double-sided layouts. There was also an additional site of 68 Josta 2-tier racks near the concourse.

Cycle-Works embedded the Kennet shelters into foundations prepared by J Murphy, while the Josta 2-tier racks were assembled and bolted down to the existing surface, using special 'Duisburg' supporting legs for non-concrete sites.

All cycle parking items were delivered in good time to meet all deadlines, and both contractors liaised well throughout the construction period to provide the best possible service to the end customer, Network Rail.

Josta 2-tier racks offer many unique features including the low, easy to use handles, patented wheeling gripping mechanism and moveable security bar.

They are also designed for a long, tough life of constant heavy use, with low maintenance. However, the most important factor is safety. A special, patented gripping mechanism ensures that the bike cannot roll back and injure the user.

cycle-works.com

MURPHY

Breathing life into infrastructure



The old low capacity Sheffield racks on the platform.

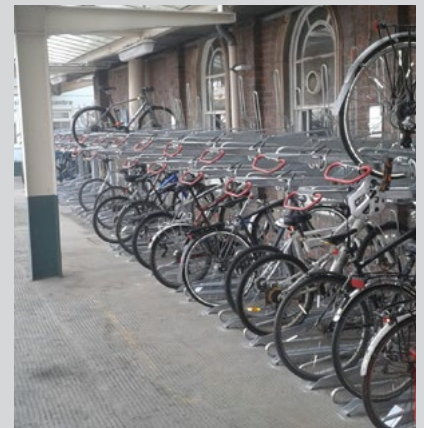

The new high capacity Josta 2-tier that replaces the Sheffield racks.



The stylish Kennet shelter covers the double sided Josta 2-tier.

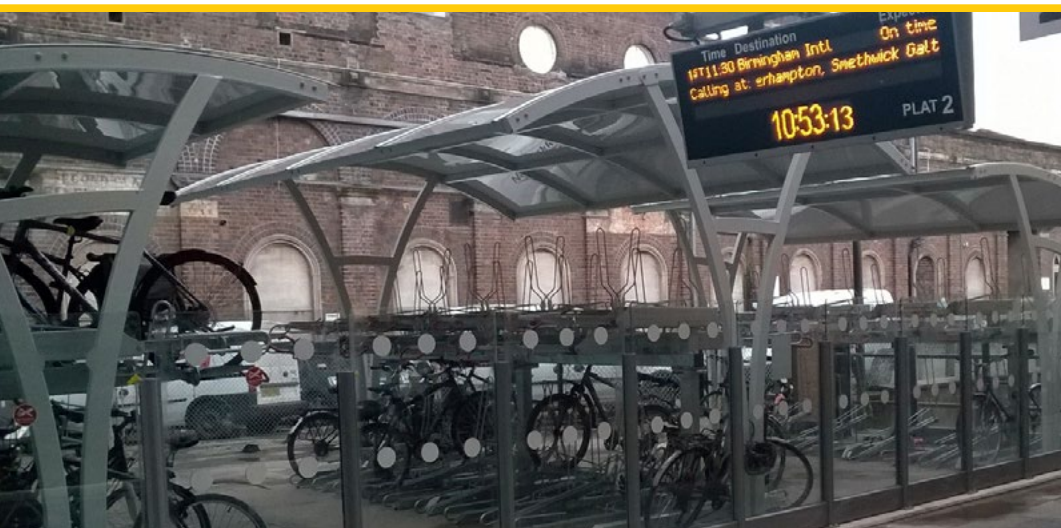

Cycle-Works
8-9 Rodney Road
Portsmouth
Hampshire
PO4 8BF

t 02392 815 555
f 02392 815 544
e info@cycle-works.com
w cycle-works.com

Cycle-Works Ltd
Registered in England 3268339



ESi.info





Case Study

Strata SE1

Strata SE1 is the tallest residential building in central London. It houses 408 apartments in two architecturally prestigious buildings, both with space for shops and restaurants below. Sustainability is a key theme in this development, which is the first building in the world to feature integrated wind turbines. Therefore a comprehensive, high quality cycle parking solution was an essential feature.

Our Solution

In order to incorporate sufficient cycle parking to serve the residents of the development it was essential that the cycle parking solution occupy the minimum floor area. For this reason we supplied a solution based on the Josta Doubleparker, the market leading two tier rack.

Two-tier racks fit double the amount of cycle parking into a given area and the Josta Doubleparker is the original and best. In operation the racks are safe, secure and easy to use for any cyclist. The clever design minimises the effort to lift the upper racks and incorporates an ingenious, patented clamp to securely hold the bike.

The two-tier racks are complemented by wall hooks and rounded-A racks. The wall hooks take advantage of unused wall space to create places for cycles to be hung vertically whilst the rounded-A racks enable secure bike parking in areas with too little headroom for two tier racks.



The bike park at Strata has two-tier parking for 302 bikes.



Rounded-A racks still provide an effective solution.



Josta Wall hooks are used to utilise all the available space.



Every inch was used to good effect.

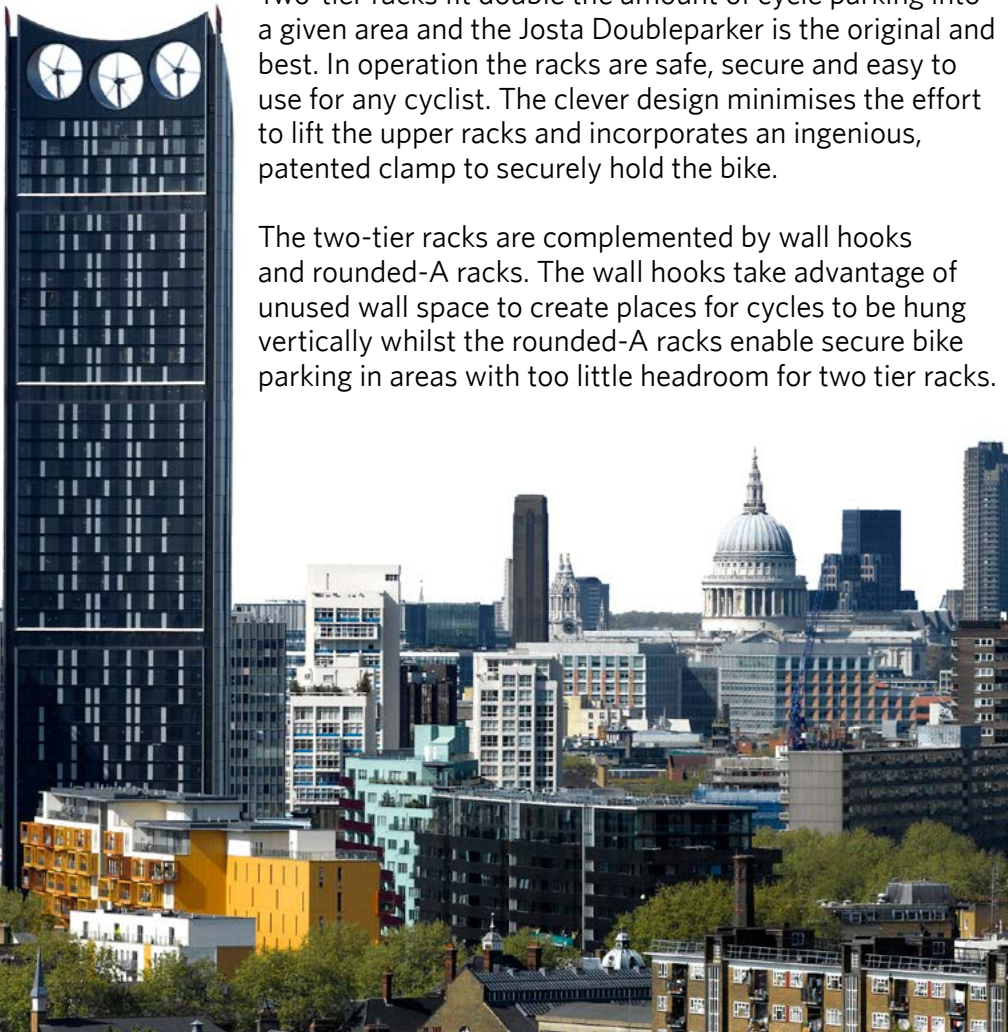



Case Study

The Bike Park - Leicester Town Hall

Located in Town Hall Square in the centre of the City of Leicester, the underground Bike Park has recently been officially re-opened after a £150,000 refurbishment project by Leicester City Council who took over the management from Groundwork Leicester.

The Bike Park is a one-stop shop for cyclists, incorporating secure cycle storage, showers and toilets, repairs, sales, hire and general advice.

Leicester City Council awarded Cycle-Works the contract to modernise and update the cycle parking area, ideally getting an increase in the number of spaces.

Our Solution

The Bike Park is situated in a number of rooms, of varying shapes and sizes, below the old Town Hall in the heart of the city.

Following an initial site visit and consultation on the plans, the best use of space was recommended. In total, 114 of the safe and easy to use Josta 2-tier racks were installed across the four rooms along with 19 Josta wall hooks to add increased capacity in areas with height restrictions or other issues.

Cycle-Works team worked on one room at a time; allowing the other rooms to carry on being used to park customers bikes.

Leicester City Council Cycling Co-ordinator, Andy Salkeld says "The number of people cycling in Leicester has more than doubled in the last 5 years and there is a clear demand for facilities to support this. The Bike Park is ideally located and, with major refurbishment, is set to become an even greater asset to the city."



The Bike Park is located under the Town Hall for ease of use.



The Josta 2-tier is perfect for this low level environment.



The Josta 2-tier is right at home on this parquet flooring.



A workshop is integrated into the Bike Park as well as showers, toilets, sales, hire and general advice.





Case Study

Haywards Heath Cycle Hub

Haywards Heath has seen a dramatic improvement in its cycle parking with the opening of a new Cycle Hub in February 2012. The 'hub' parks 304 bikes, with 144 spaces outside, under shelters, and 160 spaces indoors, in the adjacent former car valet building that has been totally transformed, specifically to accommodate cycle parking in a secure and safe environment.

Our Solution

The acclaimed Josta 2 tier rack parking system was installed in order to maximise the number of parking spaces in the assigned area and due to their safe, easy to use and durable design. Outside, 144 spaces were provided under two, 15 metre long, higher Kennet shelters. The shelters are covered by CCTV (beamed back to Southern's 24hr control in Croydon) and are well lit to offer the very best security. For increased peace of mind, the inside parking is accessed by key-card, and is also covered by CCTV.

The Josta frames have been customised in a stylish black powder coating, continuing the theme of the cycle parking at other stations on the Southern Railways network that Cycle-Works have installed, such as Hove (117 spaces), Sutton (50 spaces) and Horsham (54 spaces).

Cycle-Works completed Phase 1, the outside parking, in early December 2011 and most of the available spaces were being used before the indoor parking was opened. Phase 2 was finished just before Christmas 2011; well in time for the official opening in February 2012.

Southern Rails Project Manager, Paul Best said "Now we can provide a fantastic facility for the growing numbers of cyclists and motorcyclists who are choosing to leave the car at home and get to the station in a much more sustainable way."



Southern MD Chris Burchell, Cycle-Works MD Peter Davenport & Haywards Heath Town Mayor John Sabin.



144 Josta 2-Tier Racks under the Cycle-Works Kennet Shelter.



The Shelter is covered by 24 hour CCTV and features internal lighting.



144 Josta 2-Tier Racks under the Cycle-Works Kennet Shelter.



Case Study

Merseyrail

Cycle-Works has installed a total of 824 secure cycle parking spaces at eighteen railway stations in the Merseyside area. The new cycle parking facilities are all located in secure compounds with electronically controlled access. The scheme also offers a cycle hire and repair facility at Southport station.

Our Solution

Funding for the scheme was secured by Merseyrail and Merseytravel in a successful bid to become a UK Cycling Demonstration Train Operator in 2009. The cycle parking racks were installed by Cycle-Works in partnership with building services provider Strategic Team Group. They use a 2-tier system supplied by German manufacturer Josta to double the capacity.

The Josta 2-tier rack is a common sight at railway stations across Europe, for example Leiden in Holland has Josta racks with a capacity of around 4000 bikes. It is also becoming popular with businesses where space is often at a premium. The Josta system is widely considered to be the best available for safety, security and ease of use. Cycle-Works works has also installed 2-tier parking at stations across the UK including London Euston, Liverpool Street, Glasgow Central and Edinburgh Waverley.

Commenting on the new facilities, Strategic Team Group's business development director, Charles Tweed said: "We have built a strong reputation over the last eighteen months working in the rail sector and the installation of these facilities for cyclists marks a significant milestone. We are proud to be playing such a crucial role in adding another dimension to rail travel."

The new facilities have been installed at the following Northern and Wirral Line Stations: Southport, Birkdale, Hillside, Ainsdale, Freshfield, Formby, Hightown, Hall Road, Blundellsands & Crosby, Birkenhead, Green Lane, Rock Ferry, Bebington, Port Sunlight, Spital, Bromborough, Eastham Rake and Hooton.



Secure Cycle Parking at Hooton.



Blundellsands and Crosby.



The cycle hire scheme at Southport uses 2-tier parking too.



Cycle storage at Rock Ferry.





Case Study

Network Rail

Cycle-Works has delivered high-profile installations of two-tier cycle parking at four major stations operated by Network Rail. These stations - London Liverpool Street, London Euston, Edinburgh Waverley and Glasgow Central - are amongst the busiest in the UK..

Our Solution

Cycle-Works is the exclusive UK supplier of the Josta 2-tier rack. Over 500 Josta two-tier cycle parking spaces have been installed across these four Network Rail stations.

The installations have transformed cycle parking provision at these four stations. Gone are the cramped, overcrowded and hard to access sheffield stands and in their place are rows of neat, organised 2-tier racks.

Robin Gisby, Director of Operations and Customer Services at Network Rail, said about the Liverpool Street installation: "The new double-decker racks are safe, secure and simple to use giving more people the cleaner, greener option of cycling to and from Liverpool Street. We're pleased to have worked with TfL on this and the recent project at Euston, and will continue to explore ways to increase the provision of cycle racks at stations across the Capital and beyond."



Josta 2-Tier Racks at London Liverpool Street



Edinburgh provides 60 2-tier spaces on platform 11.



Glasgow Central provides 80 2-tier spaces on platform 15.



London Liverpool Street before and after installation of 2-tier racks.



The external racks at Euston are in a Cycle-Works shelter.