

FM82 PN16

Cast Iron Gate Valve

Crane cast iron gate valves offer the ultimate in dependable service wherever minimum pressure drop is important.

Each valve is hydrostatically tested to BS EN 12266-1: 2003.

Manufactured in accordance with BS EN 1171: 2002.

Materials

NO.	PART	MATERIAL
1	Body	Cast Iron BS EN 1561 GJL-250
2	Bonnet/Yoke	Cast Iron BS EN 1561 GJL-250
2	Bonnet	Cast Iron BS EN 1561 GJL-250
3	Disc	Cast Iron BS EN 1561 GJL-250
4	Stem	Stainless Steel 410 S21
5	Body Seat Ring	Bronze BS EN 1982 CC491K
6	Disc Seat Ring	Bronze BS EN 1982 CC491K
7	Yoke Sleeve	Bronze BS EN 1982 CC491K
8	Yoke Sleeve Retg Nut	Ductile Iron ASTM A536 65-45-12
9	Yoke Sleeve Nut	Malleable Iron BS EN 1562 GJMB 300-6
10	Gland Flange	Malleable Iron BS EN 1562 GJMB 300-6
11	Gland (2"-4")	Brass BS EN 12164 CW721R
11	Gland (5"-12")	Malleable Iron BS EN 1562 GJMB-300-6
13	Packing	Graphite
14	Bonnet Gasket	Graphite wrapped with SS304
16	Handwheel	Malleable Iron BS EN 1562 GJMB-300-6
18	Body Plate	Aluminium
20	Yoke	Cast Iron BS EN 1561 GJL-250



FM82

General Valves

Dimensions & Weights

SIZE (mm)	WEIGHT (kg)	A (mm)	B (mm)	C (mm)	D (mm)	E (mm)	F (mm)	G (mm)	H (mm)
50	22.5	178	20	165	334	399	19	203	102
65	26.4	190	20	185	354	432	19	203	122
80	31	203	22	200	375	469	19	203	135
100	44.3	229	24	220	449	566	22	229	155
125	72.3	254	26	254	575	714	28.5	305	185
150	88.1	267	26	279	649	813	28.5	305	212
200	140	292	30	340	800	1013	34.9	356	248
250	225	330	32	405	984	1257	39.7	406	320
300	314	356	32	460	1127	1454	39.7	457	378

Pressure/Temperature Ratings

TEMPERATURE (°C)	-10 to 120	200
PRESSURE (BAR)	16	12.8

Intermediate pressure ratings shall be determined by interpolation.

Dimensional Drawing

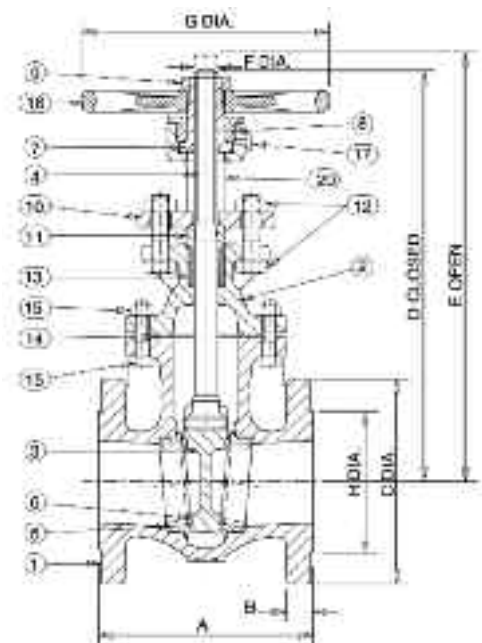

PRESSURE RATING: PN16

TEMPERATURE OPERATING RANGE: -10 to 200°C

UK END CONNECTION: Flanged BS EN 1092-2 PN16

OPERATOR: Handwheel.

Gate valves are best for services that require infrequent valve operation, and where the disc is kept either fully opened or fully closed. They are not practical for throttling.

SPECIFICATION: Valves are manufactured in accordance with BS EN 1171: 2002.

End flanges conform to BS EN 1092-2 with raised face and are normally supplied drilled. Bronze Trim, Rising Stem.

This valve is not suitable for use on group 1 gases or unstable fluids, as defined by the Pressure Equipment Directive 97/23/EC.

AVAILABLE OPTIONS: Flanges Undrilled

Every effort has been made to ensure that the information contained in this publication is accurate at the time of publishing. Crane Ltd assumes no responsibility or liability for typographical errors or omissions or for any misinterpretation of the information within the publication and reserves the right to change without notice.