

FM63 PN16

Cast Iron Gate Valve

Crane cast iron gate valves offer the ultimate in dependable service wherever minimum pressure drop is important.

Each valve is manufactured in accordance with BS EN 1171: 2002 and hydrostatically tested to BS EN 12266-1: 2003.

Materials

NO.	PART	MATERIAL
1	Body	Grey Iron BS EN 1561 GJL-250
2	Bonnet	Grey Iron BS EN 1561 GJL-250
3	Disc	Grey Iron BS EN 1561 GJL-250
4	Body Seat Ring	Bronze BS EN 1982 (CC491K)
5	Disc Seat Ring	Bronze BS EN 1982 (CC491K)
6	Stem	Stainless Steel BS 970: 410S21
7	Gasket	Graphite Graphite (Asbestos Free)
8	Gland Packing Nut	Stainless Steel BS 970: 304S31
9	Handwheel	Grey Iron BS EN 1561 EN-GJL-250
10	Stem Retaining Ring	Stainless Steel BS 970: 304S31
11	Disc Stem Nut	Bronze BS EN 1982 (CC491K)
12	Packing Ring	Graphite Graphite (Asbestos Free)
13	Body/Bonnet Bolt	Steel BS 3692 GR 8.8
14	Body/Bonnet Nut	Steel BS 3692 GR 8
15	Handwheel Retaining Nut	Steel BS 4190 GR 4
16	Handwheel Washer	Steel BS 4320
17	Body ID Plate (Not Shown)	Aluminium



FM63

Dimensional Drawing

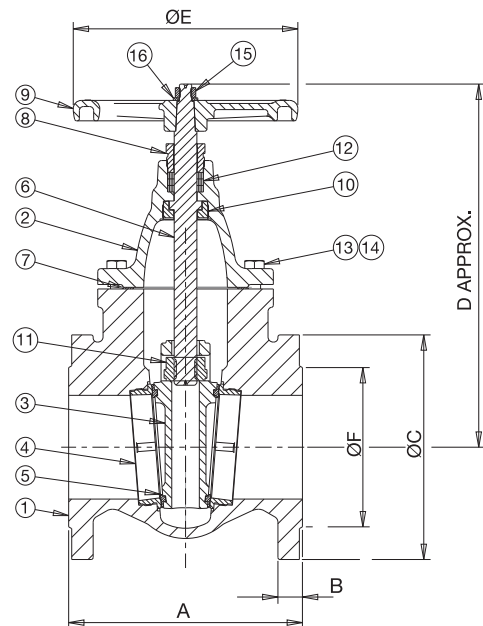

Dimensions & Weights

SIZE (mm)	WEIGHT (kg)	A (mm)	B (mm)	C (mm)	D (mm)	E (mm)	F (mm)
65	18.7	190	20	185	262	190	118
80	23.9	203	22	200	286	190	132
100	37.6	229	24	220	356	220	156
125	50.7	254	26	250	426	300	184
150	63.8	267	26	285	463	300	211
200	104.3	292	30	340	578	350	266
250	194.5	330	32	405	773	406	319
300	275.5	356	32	460	860	457	370

All dimensions are nominal.

Please note size 50mm is also available, please refer to the website.

Pressure/Temperature Ratings

TEMPERATURE (°C)	-10 to 120	200
PRESSURE (BAR)	16	12.8

Intermediate pressure ratings shall be determined by interpolation.

PRESSURE RATING: PN16

PRESSURE/TEMPERATURE OPERATING RANGE:

-10 to 120°C at 16 bar, 200°C at 12.8 bar

UK END CONNECTION: Flanged BS EN 1092-2: PN16

SPECIFICATION: Wedge Disc, Non-Rising Stem, Inside Screw, Handwheel operated.

This valve is not suitable for use on group 1 gases or unstable fluids, as defined by the Pressure Equipment Directive 97/23/EC.

AVAILABLE OPTIONS: Flanges Undrilled, P139 Stem Adapter