

FM469

PN16

Cast Iron Check Valve

Check valves permit flow in one direction only, and close automatically if flow reverses. They are entirely automatic in action, depending upon pressure and velocity of flow within the line to perform their functions of opening and closing.

Swing pattern, bronze trim, resilient seated.

Materials

PART	MATERIAL	SIZES
Body	Cast Iron BS EN 1561 GJL-250	All
Cap	Cast Iron BS EN 1561 GJL-250	All
Disc	Cast Iron BS EN 1561 GJL-250	All
Body Seat Ring	Bronze BS EN 1982 CC491K	All
Disc Ring	Nitrile Rubber	All
Hinge Pin Bush	Bronze BS EN 1982 CC491K	All
Hinge Pin Plug	Bronze BS EN 1982 CC491K	All
Hinge Pin	Stainless Steel Type 304	50 - 80
Hinge Pin	13% Cr.Steel AISI Type 410	100 - 300
Cap Bolts	Steel BS 3692 Gr.8.8	All
Cap Bolt Nuts	Steel BS 3692 Gr.8	All
Gasket	Asbestos Free	All
Body Plate	Aluminium	All
Disc Ring Retaining Nut	Cast Iron BS EN 1561 GJL-250	All
Retaining Nut Pin	Steel	All



Dimensional Drawing

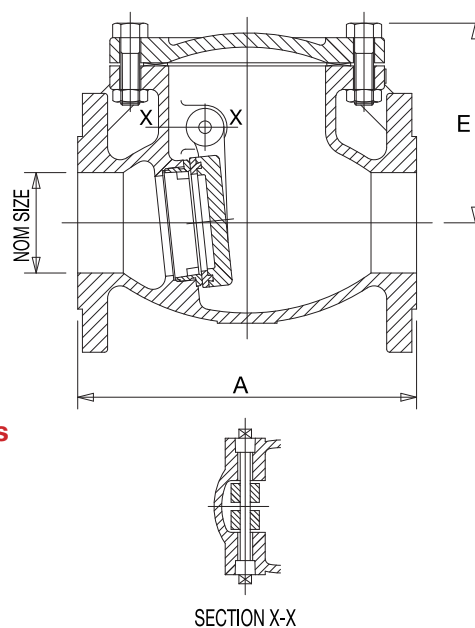

Dimensions & Weights

SIZE (mm)	WEIGHT (kg)	A (mm)	E (mm)
50	11.3	203	113
65	15.6	216	126
80	19.3	241	136
100	26.6	292	153
125	44	330	186
150	55.5	356	207
200	119	495	250
250	175	622	352
300	263	698	397

Pressure/Temperature Ratings

TEMPERATURE (°C)	-10 to 65
PRESSURE (BAR)	16

Intermediate pressure ratings shall be determined by interpolation.

PRESSURE RATING: PN16

TEMPERATURE OPERATING RANGE: -10 to 65°C

UK END CONNECTION: Flanged BS EN 1092-2 PN16

OPERATOR: Swing Check Valve

SPECIFICATION: Valves are manufactured in accordance with BS EN 12334:2001.

End flanges conform to BS EN 1092-2 Section 3.2 Table 11 with raised face and are normally supplied drilled.

This valve is not suitable for use on group 1 gases or unstable fluids, as defined by the Pressure Equipment Directive 97/23/EC.

Every effort has been made to ensure that the information contained in this publication is accurate at the time of publishing. Crane Ltd assumes no responsibility or liability for typographical errors or omissions or for any misinterpretation of the information within the publication and reserves the right to change without notice.