

## F611 / F621 / F626 PN16

**WRAS**  
APPROVED  
PRODUCT  
F621

### Semi-Lugged Lever Operated Butterfly Valves to BS EN 593: 2009

#### Features & Benefits

- Aluminium Bronze disc
- Stainless steel shaft
- Trigger lever
- Valves are suitable for use with flanges conforming to BS EN 1092-2 PN10 or PN16 and ANSI B16.1 Class 125

#### Materials

PART	MATERIAL
Body	Ductile Iron ASTM A536 (Epoxy Paint)
Disc	Aluminium Bronze
Liner (F611)	Nitrile Temp. -10 to 90°C
Liner (F621)	EPDM (WRAS Approved) Temp. -10 to 100°C
Liner (F626)	EPDM (High Temperature) Temp. -10 to 130°C
Shaft	Stainless Steel Type 410
Taper Pin	Stainless Steel Type 316
Key	Carbon Steel
O-Ring	Buna-N
Bushing	PTFE
Lever & Screw	Carbon Steel (Epoxy Paint)
Stop Plate	Carbon Steel (Zn Plated)

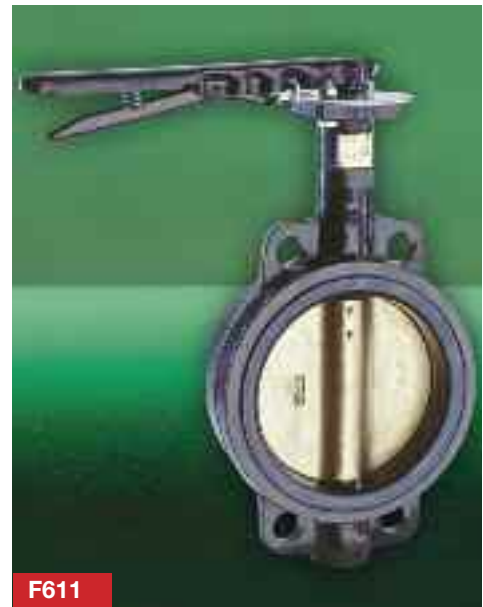

**F611**  
**Dimensional Drawing**

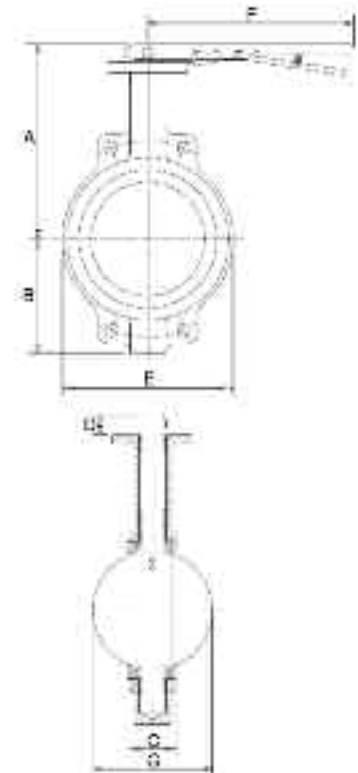

#### Dimensions & Weights

SIZE (mm)	WEIGHT (kg)	A (mm)	B (mm)	C (mm)	D (mm)	E (mm)	F (mm)	G (mm)
50	3.5	195	83	44	32	102	260	32
65	4	207	95	48	32	121	260	46
80	5.4	213	102	48	32	130	260	64
100	6.7	232	124	54	32	171	260	90
125	9	245	136	57	32	197	260	111
150	9.9	257	150	57	32	219	260	145
200	16.4	305	197	63	44	268	356	193

#### Pressure/Temperature Ratings

	F611	F621	F626
TEMPERATURE (°C)	-10 to 90	-10 to 100	-10 to 130
PRESSURE (BAR)	16	16	16

**PRESSURE RATING:** PN16 / ANSI Class 125

**END CONNECTION:** Semi-Lugged

**OPERATOR:** Trigger Lever

#### SPECIFICATION:

F611 - Suitable for Group 1 and 2 gases and Group 1 and 2 liquids as defined by the Pressure Equipment Directive 97/23/EC.

F621 - Suitable for Group 2 liquids only as defined by the Pressure Equipment Directive 97/23/EC and these valves are WRAS approved.

Suitable for Group 2 liquids only as defined by the Pressure Equipment Directive 97/23/EC.

Every effort has been made to ensure that the information contained in this publication is accurate at the time of publishing. Crane Ltd assumes no responsibility or liability for typographical errors or omissions or for any misinterpretation of the information within the publication and reserves the right to change without notice.