

## F615 / F625 / F629 PN16

**WRAS**  
APPROVED  
PRODUCT  
Sizes 50-300mm

### Fully-Lugged Gearbox Operated Butterfly Valves to BS EN 593: 2009

#### Features & Benefits

- Aluminium Bronze disc
- Stainless steel shaft
- Gearbox operated
- Valves are suitable for use with flanges conforming to BS EN 1092-2 PN10 or PN16 - Sizes 65-200mm
- BS EN 1092-2 PN16 flanges only - Sizes 250-600mm PN16 only

#### Materials

PART	MATERIAL
Body	Ductile Iron ASTM A536 (Epoxy Paint)
Disc	Aluminium Bronze
Liner (F615)	Nitrile Temp. -10 to 90°C
Liner (F625)	EPDM (WRAS Approved) Temp. -10 to 100°C
Liner (F629)	EPDM (High Temperature) Temp. -10 to 130°C
Shaft	Stainless Steel Type 410
Taper Pin	Stainless Steel Type 316
Key	Carbon Steel
O-Ring	Buna-N
Bushing	PTFE



#### Dimensions & Weights

SIZE (mm)	WEIGHT (kg)	A (mm)	B (mm)	C (mm)	D (mm)	E (mm)	F (mm)	G (mm)	K (mm)
50	15.5	162	83	44	42	102	150	32	240
65	16	175	95	48	42	121	150	46	240
80	18.7	181	102	48	42	130	150	64	240
100	24.1	200	124	54	42	171	150	90	240
125	25	213	136	57	42	197	300	111	240
150	26.4	225	150	57	42	219	300	145	240
200	36.7	260	197	63	40	268	300	193	230
250	47.1	292	210	70	40	332	300	241	230
300	62.1	337	248	79	40	410	300	290	230
350	84.9	368	279	79	40	435	300	325	230
400	123.8	400	305	89	-	508	450	380	277
450	139.7	422	381	108	-	543	450	427	277
500	215.5	479	381	133	-	592	450	474	321
600	337.3	562	457	156	-	708	450	574	335

#### Dimensional Drawing

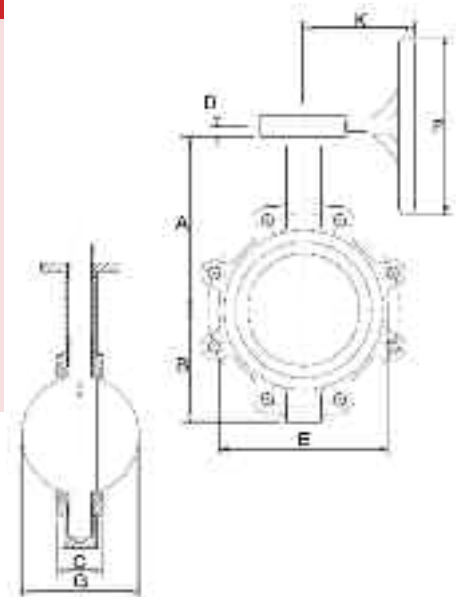

#### Pressure/Temperature Ratings

	F615	F625	F629
TEMPERATURE (°C)	-10 to 90	-10 to 100	-10 to 130
PRESSURE (BAR)	16	16	16

**PRESSURE RATING:** PN16  
**END CONNECTION:** Lugged  
**OPERATOR:** Gearbox

#### SPECIFICATION:

F615 - Suitable for Group 1 and 2 gases and Group 1 and 2 liquids as defined by the Pressure Equipment Directive 97/23/EC.  
 F625 - Suitable for Group 2 liquids only as defined by the Pressure Equipment Directive 97/23/EC and these valves are WRAS approved.  
 Suitable for Group 2 liquids only as defined by the Pressure Equipment Directive 97/23/EC.

Every effort has been made to ensure that the information contained in this publication is accurate at the time of publishing. Crane Ltd assumes no responsibility or liability for typographical errors or omissions or for any misinterpretation of the information within the publication and reserves the right to change without notice.