

F611/F612/F614/F615/F626/F627/F628/F629 GEM Butterfly Valves

- These instructions relate only to Crane GEM rubber lined Butterfly valves, which are designed and manufactured to provide isolation, or can be used for regulation, of flow of suitable fluids.
- Design, manufacture and testing of these valves are subject to a Quality Assurance System and Procedures according to EN ISO 9001. Service temperature and pressures indicated on the identification plate or body marking should not be exceeded.
- Crane GEM Butterfly valves have not been designed as fire safe valves.
- Valves must be installed into a well-designed system and it is recommended that the system be inspected in accordance with the appropriate member state legislation. In the UK - The Pressure Systems Safety Regulations 2000.

INSTALLATION

Storage

- If valves are to be stored prior to installation, ensure that action is taken to protect valves:
- Store valves with discs at 5° from fully closed position.
- Protect against frost, contamination and corrosion.
- Cover valves to prevent ingress of dust and debris.
- Ensure that pipe flanges are clean, to prevent damage to valve flanges/liners on installation.
- Check that internal pipe diameter has sufficient clearance for valve disc to be fully operated.
- Check that there are no restrictions to full operation of valve disc in pipework, i.e. internal welding of flanges.
- Check that the pipe flanges are parallel, and on same centreline, before installation.

Preparation

- Before installation, ensure valve is suitable for service conditions e.g. pressure, temperature, service media.
- All welding and heat treating of flanges must be completed prior to installation of valves to prevent damage to liners from excessive heat.

- The valves have been designed for loadings, appropriate to intended use and other reasonably foreseeable operating conditions. Loadings caused by traffic, wind and earthquake have not been taken into account.
- It is the responsibility of the installer to ensure that the valves do not exceed the allowable limits of pressure. However the equipment is designed to withstand a momentary pressure surge of up to 10% of the maximum working pressure.
- The piping system shall be so designed to reduce the risk of fatigue due to vibration of pipes.
- The Installation shall be designed to provide adequate means of draining and venting to avoid harmful effects such as water hammer, vacuum collapse, corrosion and uncontrolled chemical reactions and to permit cleaning, inspection and maintenance in the correct manner.
- The product has not been designed to include corrosion, erosion or abrasion allowances. Any queries regarding service applications should be addressed to the Crane Fluid Systems - Technical Sales Department.

Valve Location

- Valves should be located to ensure ease and safety of operation and access allowed for subsequent maintenance of the valve, especially where actuators are fitted. Where valves are lever operated, ensure there are no obstructions which may prevent full travel of the lever.
- It is also important to ensure that valves are not subject to turbulent flows, and recommendations are shown below:

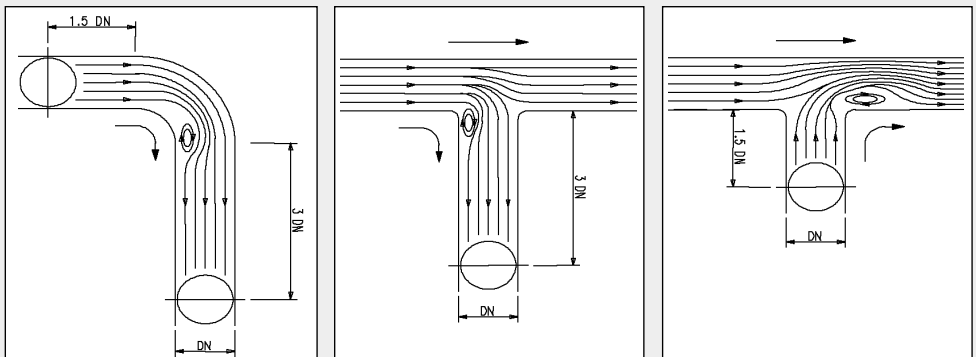

Piping supports

- These must be carefully aligned and at the correct distance between centres for the size and type of pipe. The following publications provide details of correct spans and installation details: BS3974, Specification for Pipe Supports (Available from BSI) DOI Directorate of M & E Engineering Services, M & E No. 3 (Available from HMSO)

Flange supports

- It is prohibited to add an additional gasket between the pipe flange and the valve body.
- Ensure that all pipe flanges are cleaned prior to installation of valves to prevent damage to valve liners.

End of line service

- In certain circumstances it may be necessary to use these valves on an End of Line service. In these instances, ensure that system pressure does not exceed 10 bar for sizes DN50 to DN300 and 6 bar for sizes above DN300.

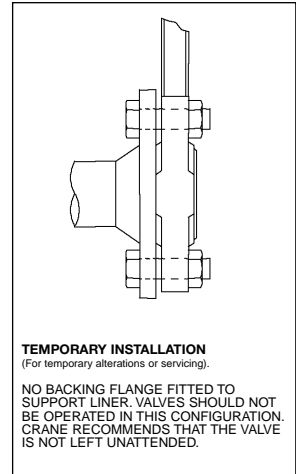
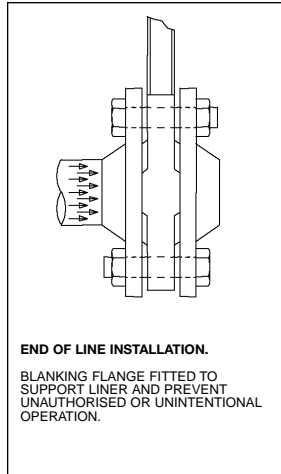
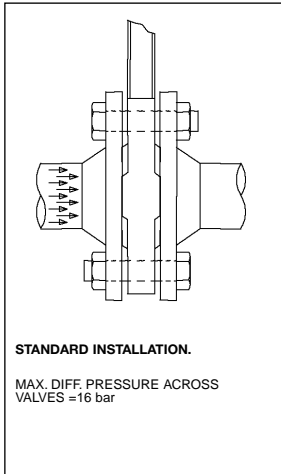

- Where valves are used for End of Line service, the valve should be protected against unauthorised or unintentional operation to prevent personal injury or damage to equipment.

OPERATION

- Butterfly Valves are quarter turn for full operation - the valves are closed by turning clockwise, and opened by turning anti-clockwise.
- Check that valves operate fully prior to commissioning and that there are no obstructions to the full travel of the disc. The disc enters the pipeline by the amount shown in the drawing when the valve is in the fully open position. Ensure there are no obstructions upstream or down stream of the valve to prevent correct operation.
- On actuated valves, the end stops and torque limiters will have been adjusted and set prior to despatch from factory.

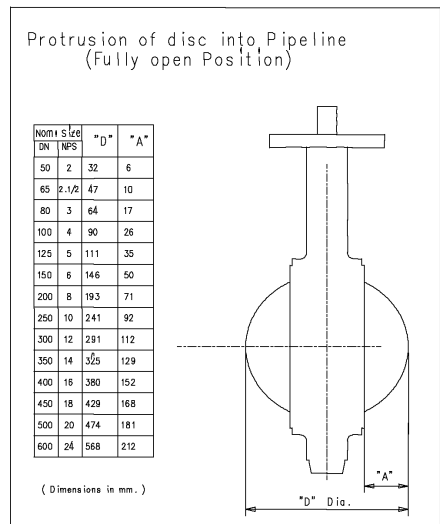

GENERAL CONSIDERATIONS

- Valves become increasingly de-rated with increase in service temperatures. Maximum operating pressure reduces as service temperature increases. Data concerning pressure limitations due to elevated temperature may be found in graphical form on the Crane website, www.cranefs.com
- Valves are not designed to operate under high shock loadings. Where pressure increases occur due to shock loading (water hammer), they should be added to the working pressure to obtain the total pressure acting on the valve. The total should not exceed the valve rating. A pressure surge, or shock, is usually caused by a sudden reduction in flow rate, such as is caused by the rapid closure of a check or quarter turn valve, and may severely limit design velocities. The value is dependent on the velocity of the liquid, not system pressure, and may increase by up to 4 bar for every 0.3m/sec. increase in fluid velocity.
- The surfaces of valves in service may be subject to extreme temperatures; care should be taken when handling.

Body Style/ Fig No.	LINER MATERIAL / TEMPERATURE LIMITS	PED Category by Valve Size (DN)			Product Applications			
		1	2	3	Group 1 Gas	Group 2 Gas	Group 1 Liquid	Group 2 Liquid
F611 LEVER, SEMI LUGGED F614 LEVER, FULLY LUGGED	NITRILE -10 to 82 °C	50	65 - 200		✓	✓	✓	✓
F612 GEARBOX, SEMI LUGGED F615 GEARBOX, FULLY LUGGED	NITRILE -10 to 82 °C	50	65 - 200	200 - 600	✓	✓	✓	✓
F626 LEVER, SEMI LUGGED F628 LEVER, FULLY LUGGED	EPDM -10 to 130 °C	50	65 - 200		✓	✓	✓	✓
F627 LEVER, SEMI LUGGED F629 GEARBOX, FULLY LUGGED	EPDM -10 to 130 °C	50	65 - 200	200 - 600	✓	✓	✓	✓



FLUID SYSTEMS