

F58

Class 125

Cast Iron Gate Valve

Crane cast iron gate valves offer the ultimate in dependable service wherever minimum pressure drop is important.

Materials

PART	MATERIAL	SIZES
Body	Cast Iron BS EN 1561 GJL-250	All
Bonnet	Cast Iron BS EN 1561 GJL-250	All
Disc	Cast Iron BS EN 1561 GJL-250	All
Stem	13% Cr.Steel BS 970 Pt.1 410S21 or 431S29	All
Body Seat Ring	Bronze BS EN 1982 CC491K	All
Disc Ring	Bronze BS EN 1982 CC491K	All
Yokesleeve	Bronze BS EN 1982 CC491K	All
Yokesleeve Nut	Ductile Iron ASTM A536 65-45-12	2, 3, 5, 8 & 10
Yokesleeve Nut	Cast Iron BS EN 1561 GJL-250	2 ¹ / ₂ , 4, 6 & 12
Yokesleeve Ret'g Nut	Ductile Iron ASTM A536 65-45-12	2, 3, & 5
Yokesleeve Ret'g Nut	Cast Iron BS EN 1561 GJL-250	2 ¹ / ₂ , 4, 6 & 12
Disc Stem Nut	Bronze BS EN 1982 CC491K	All
Gland	Cast Iron BS EN 1561 GJL-250	All
Packing	Asbestos Free	All
Gasket	Asbestos Free	All
Yoke	Cast Iron BS EN 1561 GJL-250	8, 10 & 12
Handwheel	Malleable Iron BS EN 1562 GJMB-300-6	All



F58

General Valves

Dimensional Drawing

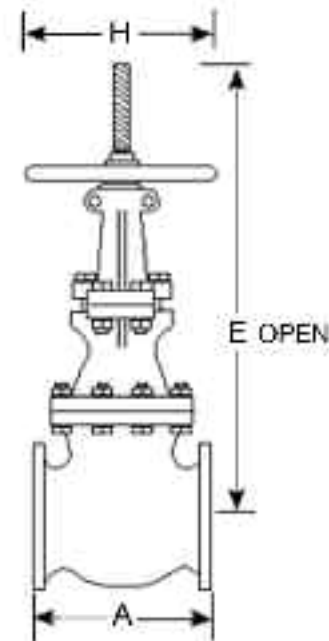

Dimensions & Weights

SIZE (inch)	WEIGHT (kg)	A (mm)	E (mm)	H (mm)
2	17	178	365	152
2 ¹ / ₂	20	190	448	152
3	28	203	481	203
4	38	229	622	229
5	56	254	672	254
6	60	267	835	254
8	112	292	989	305
10	185	330	1208	356
12	242	356	1469	406

Pressure/Temperature Ratings

TEMPERATURE (°C)	-10 to 65	230
PRESSURE (BAR)	13.8	8.6

Intermediate pressure ratings shall be determined by interpolation.

PRESSURE RATING: Class 125

TEMPERATURE OPERATING RANGE: -10 to 230°C

US END CONNECTION: ANSI Class 125

OPERATOR: Handwheel.

Gate valves are best for services that require infrequent valve operation, and where the disc is kept either fully opened or fully closed. They are not practical for throttling.

SPECIFICATION: Valves are manufactured in accordance with BS 5150: 1990. End flanges conform to BS 1560 section 3.2/ANSI B16.1 Class 125 with flat face and are normally supplied drilled. Wedge Disc, Rising Stem, Outside Screw and Yoke.

This valve is not suitable for use on group 1 gases or unstable fluids, as defined by the Pressure Equipment Directive 97/23/EC.

AVAILABLE OPTIONS: Flanges Undrilled. P50 Locking Device

Every effort has been made to ensure that the information contained in this publication is accurate at the time of publishing. Crane Ltd assumes no responsibility or liability for typographical errors or omissions or for any misinterpretation of the information within the publication and reserves the right to change without notice.