

DPAF951 - Flow • DPAR951 - Return Differential Pressure Control Valves



To meet the growing use of variable speed pumps for HVAC applications, Crane Fluid Systems has launched a range of Differential Pressure Control Valves (DPCV) specifically aimed at optimising system performance. Extremely efficient, the DPCV is set to a maximum differential pressure which ensures flow cannot exceed a desired rate. It therefore helps reduce energy consumption, the risk of noise and simplifies the commissioning process.

Materials

| ITEM | DESCRIPTION | MATERIAL |
|------|---------------|---------------------------------------|
| 1 | Body | Bronze BS EN 1982 (CC491K) |
| 2 | Bonnet | Bronze BS EN 1982 (CC491K) |
| 3 | Chamber | Bronze BS EN 1982 (CC491K) |
| 4 | Adjuster | Nylon Grade PA6 |
| INT | Stem / Piston | Stainless Steel BS EN 10088 - 1: 2005 |
| INT | Diaphragm | Rubber EPDM |
| INT | O-Ring Seals | Rubber EPDM |

See diagrams for item numbers.

INT denotes an internal component not visible on these drawings.

Dimensional Drawing

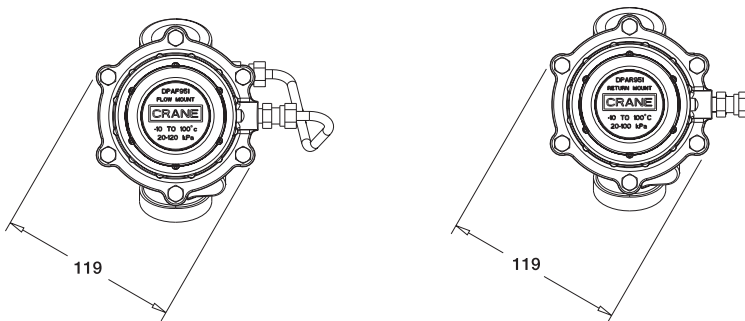

Flow Configuration

Top View

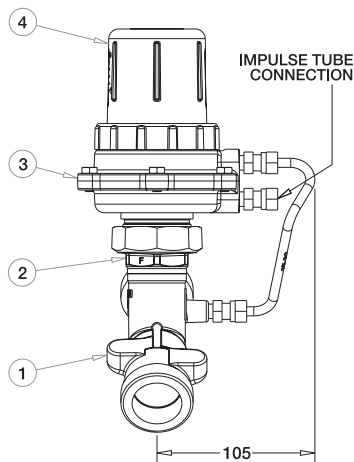

Flow Configuration

Front View

Return Configuration

Top View

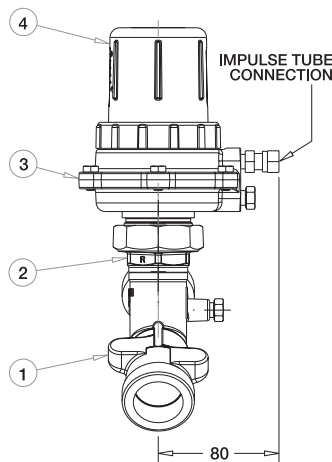

Return Configuration

Front View



DPCV

Dimensions & Weights

| DN | A (mm) | B (mm) | END CONNECTION | WEIGHT (kg) |
|----|--------|--------|--------------------------|-------------|
| 15 | 90 | 175 | 3/4" BSP Parallel Male | 2.34 |
| 20 | 96 | 175 | 1" BSP Parallel Male | 2.39 |
| 25 | 114 | 185 | 1 1/4" BSP Parallel Male | 2.62 |
| 32 | 132.5 | 190 | 1 1/2" BSP Parallel Male | 2.76 |
| 40 | 150.5 | 195 | 3/4" BSP Parallel Male | 3.07 |
| 50 | 184 | 205 | 2 3/8" BSP Parallel Male | 3.57 |

Male and female tailpieces are available - please contact Crane Fluid Systems.

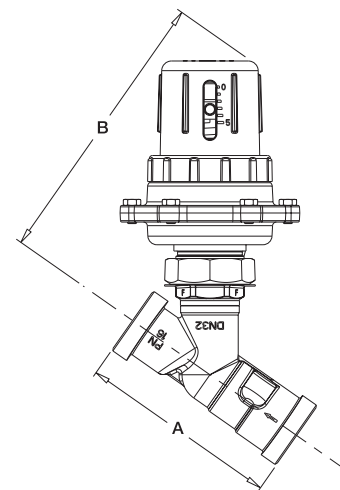

Flow & Return Configuration

Side View

Every effort has been made to ensure that the information contained in this publication is accurate at the time of publishing. Crane Ltd assumes no responsibility or liability for typographical errors or omissions or for any misinterpretation of the information within the publication and reserves the right to change without notice.