

# DM161 PN25

## Bronze Gate Valve

Crane gate valves offer the ultimate in dependable service wherever minimum pressure drop is important.

### Materials

NO.	PART	MATERIAL	SIZE
1	Body	Bronze BS EN 1982 CC491K	All
2	Bonnet	Bronze BS EN 1982 CC491K	All
3	Disc	Bronze BS EN 1982 CC491K	All
4	Stem	Bronze BS EN 1982 CC491K	2 <sup>1</sup> / <sub>2</sub> & 3
4	Stem	DZR Brass BS EN 12164 CW602N	3 <sup>3</sup> / <sub>4</sub> - 2
5	Packing	Asbestos Free	All
6	Gland	Brass BS EN 12164 CW614N	All
7	Packing Nut	Brass BS EN 12164 CW614N	All
8	Stuffing Box	DZR Brass BS EN 12164 CW602N	1 <sup>1</sup> / <sub>4</sub> & 1 <sup>1</sup> / <sub>2</sub>
8	Stuffing Box	Brass BS EN 12164 CW614N	2" only
8	Stuffing Box	Bronze BS EN 1982 CC491K	2 <sup>1</sup> / <sub>2</sub> & 3
8	Stem Bush	Al. Bronze NES 834 Pt.2	3 <sup>3</sup> / <sub>4</sub> & 1
9	Handwheel	Malleable Iron BS EN 1562 GJMB-300-6	3" only
9	Handwheel	Aluminium	3 <sup>3</sup> / <sub>4</sub> - 2 <sup>1</sup> / <sub>2</sub>
10	Handwheel Nut	Brass BS EN 12164 CW614N	All
11	ID Plate	Aluminium	All
12	Gasket	Asbestos Free	3" only



DM161

General Valves

### Dimensional Drawing

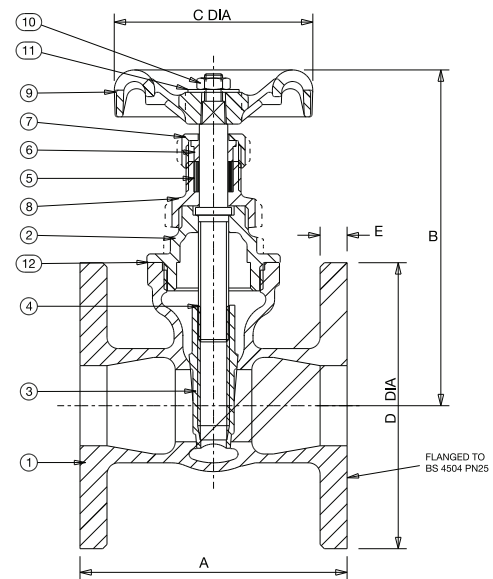

### Dimensions & Weights

SIZE (mm)	WEIGHT (kg)	A (mm)	B (mm)	C (mm)	D (mm)	E (mm)
50	7.5	135	189	92	165	11
65	10.8	165	232	103	185	13
80	14.4	185	264	121	200	14
20	1.73	90	105	52	105	8
25	2.5	100	116	65	115	9
32	4.33	110	145	70	140	9
40	5.75	120	165	78	150	11

**PRESSURE RATING:** PN25

**TEMPERATURE OPERATING RANGE:** -10 to 186°C

**UK END CONNECTION:** Flanged BS 4504

**US END CONNECTION:** Not Specified

**OPERATOR:** Handwheel.

Gate valves are best for services that require infrequent valve operation, and where the disc is kept either fully opened or fully closed. They are not practical for throttling.

**SPECIFICATION:** Valves are manufactured in accordance with BS 5154 PN25 for Series B ratings, having 'short' face-to-face dimensions. Non-Rising Stem. End flanges conform to BS 4504 Section 3.3 with flat face and are normally supplied drilled. Note: Users' attention is drawn to BS 4504 Section 3.3, Clause 8 regarding types of gaskets and mating flanges to be used with metric flanged valves.

This valve is not suitable for use on group 1 gases or unstable fluids, as defined by the Pressure Equipment Directive 97/23/EC.

**AVAILABLE OPTIONS:** Flanges Undrilled

Every effort has been made to ensure that the information contained in this publication is accurate at the time of publishing. Crane Ltd assumes no responsibility or liability for typographical errors or omissions or for any misinterpretation of the information within the publication and reserves the right to change without notice.