

# D297

## Strainer - PN32



### Features & Benefits

- Eliminate the problems caused by foreign matter within piping systems
- Perforated stainless steel screen with robust design, low flow resistance and high quality materials
- WRAS approved for use on hot and cold water systems up to 85°C
- 0.75mm screen perforations

### Materials

PART	MATERIAL	SPECIFICATION
Body	Bronze	BS EN 1982 CC491K
Cap	Bronze	BS EN 1982 CC491K
Strainer Mesh	Stainless Steel	Type 304
Gasket	Klingsil	C4430
ID Plate	Anodised Aluminium	

### Dimensions & Weights

SIZE (inch)	A (mm)	B (mm)	C (mm)	D (mm)	E (mm)	F (mm)	G (mm)	H (mm)	WEIGHT (kg)
1/2	71	29	42	49	63	27	35	144	0.27
3/4	86	35	51	60	77	33	44	176	0.44
1	101	45	55	67	90	42	54	202	0.78
1 1/4	134	54	80	93	120	50	63	294	1.30
1 1/2	148	63	87	103	134	58	73	322	1.81
2	176	77	98	119	157	71	93	367	3.10

### Pressure/Temperature Ratings

TEMPERATURE (°C)	-10 to 100	130	150	180	200
PRESSURE (BAR)	32	26.5	22.8	17.4	14

Intermediate pressure ratings shall be determined by interpolation.



### Dimensional Drawings

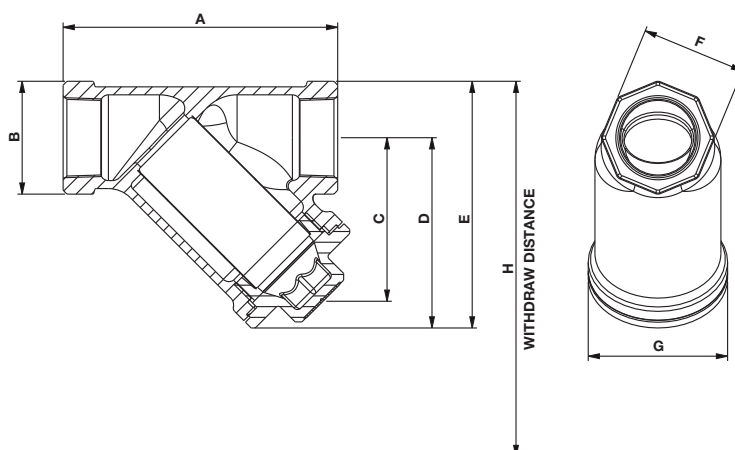

**PRESSURE RATING:** PN32 • **TEMPERATURE OPERATING RANGE:** -10 to 200°C

**UK END CONNECTION:** Taper threaded to BS EN 10226-2 • **US END CONNECTION:** ANSI B1.20.1

**SPECIFICATION:** Strainers fitted with stainless steel perforated strainer element with 0.75mm diameter holes. Screens fitted into Crane Strainers conform to the high standards of materials and workmanship associated with all Crane products. This strainer is not suitable for use on group 1 gases, group 2 gases or unstable fluids, as defined by the Pressure Equipment Directive 97/23/EC.



CRANE HOUSE  
EPSILON TERRACE,  
WEST ROAD, IPSWICH  
SUFFOLK IP3 9FJ

TELEPHONE: +44 (0)1473 277300  
FAX: +44 (0)1473 277301  
EMAIL: [enquiries@cranefs.com](mailto:enquiries@cranefs.com)  
[www.cranefs.com](http://www.cranefs.com)

Every effort has been made to ensure that the information contained in this publication is accurate at the time of publishing. Crane Ltd assumes no responsibility or liability for typographical errors or omissions or for any misinterpretation of the information within the publication and reserves the right to change without notice.

CFS\_D297\_09\_2013