

## D255C PN16



### Features & Benefits

- Robust and high quality bronze body with integral seating surfaces
- Offers the ultimate in dependable service wherever minimum pressure drop is important
- WRAS approved for use with wholesome (potable) water
- Inside screw pattern with non-rising stem

### Materials

PART	MATERIAL
Body	Bronze BS EN 1982 CC491K
Bonnet	Bronze BS EN 1982 CC491K
Stem	DZR Brass BS EN 12164 CW602N
Disc	Bronze BS EN 1982 CC491K
Stem Retainer	DZR Brass BS EN 12164 CW602N
Packing Ring	Asbestos Free
Gland (28-54 only)	Brass BS EN 12164 CW614N
Lockshield	Brass BS EN 12164 CW614N
Compression Olive	Brass BS EN 12449:1999 CW505L OR CW507L
Compression Nut	Brass BS EN 12165 CW617N



D255C

General Valves

### Dimensions & Weights

SIZE (mm)	WEIGHT (kg)	A (mm)	B (mm)	D (mm)
15	0.34	69	78	26.5
22	0.50	75	90	23.5
28	0.70	86	110	25.5
35	0.95	100	115	30.5
42	1.45	111	136	34.5
54	2.50	133	160	37

### Pressure/Temperature Ratings

TEMPERATURE (°C)	16.0	14.3	12.6	10.0	8.7	7.8	6.9	6.0	5.0
PRESSURE (BAR)	-10 to 30	40	50	65	80	90	100	110	120

Intermediate pressure ratings shall be determined by interpolation.

### Dimensional Drawing

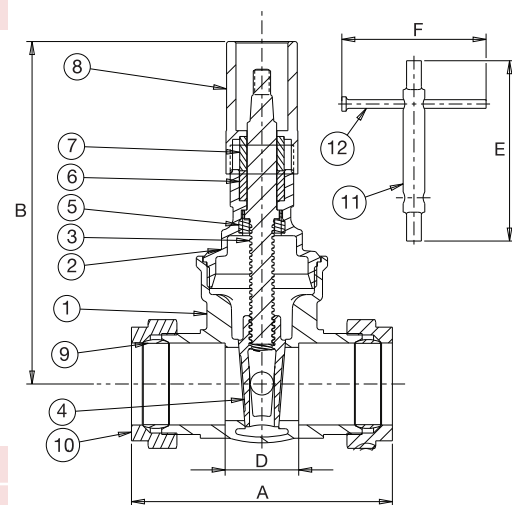

**PRESSURE RATING:** PN16

**UK END CONNECTION:** Compression ends to BS EN 1057:2006: Half hard R250

**OPERATING INSTRUCTIONS:** Lockshield.

Gate valves are best for services that require infrequent valve operation, and where the disc is kept either fully opened or fully closed. They are not practical for throttling.

**SPECIFICATION:** Valves are manufactured in accordance with BS EN 12288: 2010 (formerly BS 5154) PN16 for Series B ratings, but are limited to the pressure/ temperature ratings detailed in BS EN 1057: 2006 for compression end fittings.

This valve is to be used on Group 2 liquids only, as defined by the Pressure Equipment Directive 97/23/EC.

**AVAILABLE OPTIONS:** P100 and P102 Lockshield Keys

Every effort has been made to ensure that the information contained in this publication is accurate at the time of publishing. Crane Ltd assumes no responsibility or liability for typographical errors or omissions or for any misinterpretation of the information within the publication and reserves the right to change without notice.