

## D185AT PN64

### Materials

NO.	PART	MATERIAL	SIZE
1	Body	Bronze BS EN 1982 CC491K	-
2	Bonnet	Bronze BS EN 1982 CC491K	-
3	Union Ring	Bronze BS EN 1982 CC491K	-
4	Disc	Nickel Alloy	-
5	Stem	Aluminium Bronze BS EN 12163 CW301G	-
6	Packing	Asbestos Free	-
7	Gland	Brass BS EN 12164 CW614N	-
8	Packing Nut	Brass BS EN 12164 CW614N	1/4 - 1 1/2
8	Packing Nut	Bronze BS EN 1982 CC491K	2
9	Handwheel	Aluminium	1/4 - 1 1/2
9	Handwheel	Malleable Iron BS EN 1562 MB-300-6	2
10	Handwheel Nut	Brass BS EN 12164 CW614N	-
11	Bonnet Stud	Steel BS 970 - 605M32'T'	-
12	Bonnet Stud Nut	Steel BS 1490 GRADE 8	-
13	Gasket	Asbestos Free	-
14	Identity Plate	Aluminium	-



D185AT

General Valves

### Dimensions & Weights

SIZE (inch)	WEIGHT (kg)	A (mm)	B (mm)	C (mm)
1/4	0.38	54	133	65
3/8	0.56	54	133	65
1/2	0.81	61	152	70
3/4	1.20	70	180	78
1	1.96	81	212	92
1 1/4	3.24	88	243	103
1 1/2	4.64	96	276	121
2	7.37	109	336	152

### Dimensional Drawing

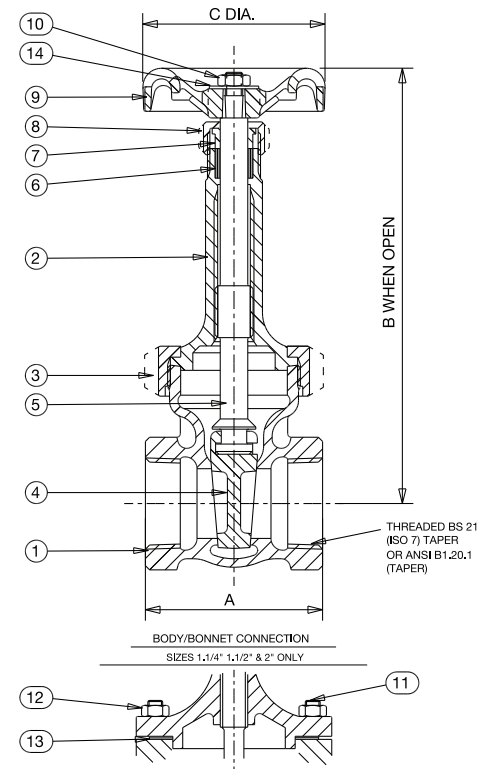

Every effort has been made to ensure that the information contained in this publication is accurate at the time of publishing. Crane Ltd assumes no responsibility or liability for typographical errors or omissions or for any misinterpretation of the information within the publication and reserves the right to change without notice.