

D171A / D171AEXS PN25



D171A Threaded DZR Ball Valve

D171AEXS Threaded DZR Ball Valve with Extension Stem

Designed to be light, compact and easy to install and operate, Crane's next generation DZR ball valve is WRAS approved and features improved leak resistance and reduced risk of damage from over tightening.

Materials

PART	MATERIAL	QUANTITY
Hex-Nut	Steel Plated	1
Lever	Steel Dacromet Plated	1
Sleeve	Maroon PVC	1
Packing Nut	Brass CW617N	1
Packing Gland	PTFE WRAS approved	1
Body	DZR Brass CW602N	1
Seats	PTFE WRAS approved	2
Ball	DZR Brass CW602N Chrome Plated	1
O-Ring	Rubber EPDM WRAS approved	1
Bonnet	DZR Brass CW602N	1
Stem	DZR Brass CW602N	1
Extension Stem Outer	Aluminium	1
Extension Stem Inner	Steel Plated	1



D171A



D171AEXS

General Valves

Dimensions & Weights

SIZE (inch)	WEIGHT (g) A	WEIGHT (g) AEXS	L (mm)	L1 (mm)	L2 (mm) A	H (mm) A	H (mm) AEXS
1/4	152	-	45.3	12	89	41	-
3/8	136	-	45.3	12	89	41	-
1/2	205	270	58.5	15.5	98.5	48	103
3/4	302	366	67	17	98.5	51	107
1	511	589	80.5	21	125	62	116
1 1/4	890	1009	94	23	140	77.5	129
1 1/2	1292	1410	102	23	140	83.5	135
2	2238	2283	124	26.5	165	97.5	150

Dimensional Drawing

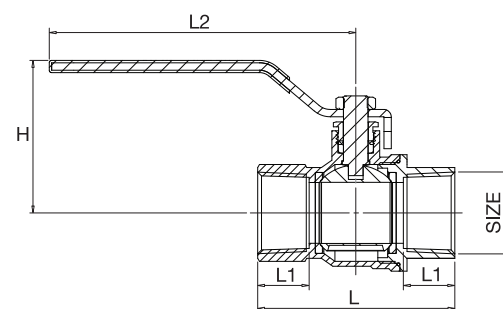

All dimensions are nominal.

Pressure/Temperature Ratings

Threaded

TEMPERATURE (°C)	-10 to 100	120
PRESSURE (BAR)	25	21.8

Intermediate pressure ratings shall be determined by interpolation.

PRESSURE RATING: PN25

TEMPERATURE OPERATING RANGE: -10 to 120°C

UK END CONNECTION: Taper threaded to BS EN 10226-2 (ISO 7-1) formerly BS 21

US END CONNECTION: ANSI B1.20.1:1983 (please add suffix AT to denote American Thread)

OPERATOR: Lever

SPECIFICATION: Quarter Turn

Every effort has been made to ensure that the information contained in this publication is accurate at the time of publishing. Crane Ltd assumes no responsibility or liability for typographical errors or omissions or for any misinterpretation of the information within the publication and reserves the right to change without notice.