

D160 Class 100

Bronze Gate Valve

Crane gate valves offer the ultimate in dependable service wherever minimum pressure drop is important.

Materials

PART	MATERIAL	SIZE
Body	Bronze BS EN 1982 CC491K	-
Bonnet	Bronze BS EN 1982 CC491K	-
Disc	Bronze BS EN 1982 CC491K	-
Stem	Bronze BS EN 12164 CW602N	-
Packing	Asbestos Free	-
Gland	Brass BS EN 12164 CW614N	-
Packing Nut	Brass BS EN 12164 CW614N	-
Stuffing Box	Bronze BS EN 12164 CW602N	-
Handwheel	Aluminium	-
Handwheel Nut	Brass BS EN 12164 CW614N	-
Identity Plate	Aluminium	-
Gasket*	Asbestos Free	3" only



Dimensional Drawing

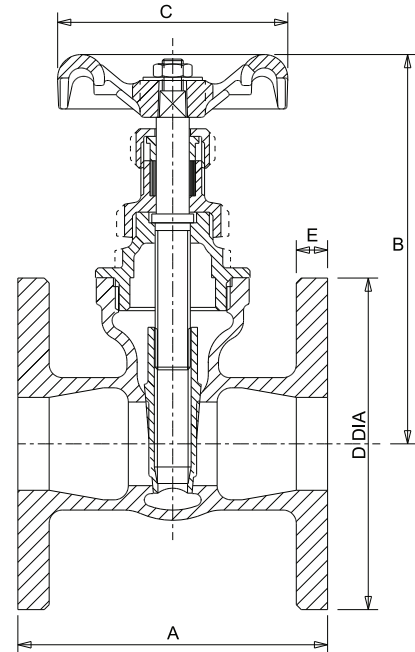

Dimensions & Weights

SIZE (inch)	WEIGHT (kg)	A (mm)	B (mm)	C (mm)	D (mm)	E (mm)
3/4	2.01	83	107	52	102	6.4
1	2.49	89	124	65	114	7.9
1 1/4	2.86	102	145	70	121	7.9
1 1/2	4.10	114	165	78	133	9.5
2	5.54	127	189	92	152	9.5
2 1/2	8.39	140	232	103	165	11.1
3	11.6	152	269	121	184	12.7

PRESSURE RATING: Class 100

TEMPERATURE OPERATING RANGE: -10 to 170°C

UK END CONNECTION: BS 10 Table E

OPERATOR: Handwheel.

Gate valves are best for services that require infrequent valve operation, and where the disc is kept either fully opened or fully closed. They are not practical for throttling.

SPECIFICATION: Solid wedge disc, Non-rising stem, screwed-in bonnet. Valves are manufactured in accordance with BS 1952 Class 100 for series B ratings. End flanges conform to BS 10 Table E with flat face and are normally supplied drilled. This valve is not suitable for use on group 1 gases or unstable fluids, as defined by the Pressure Equipment Directive 97/23/E.

AVAILABLE OPTIONS: Flanges undrilled

Every effort has been made to ensure that the information contained in this publication is accurate at the time of publishing. Crane Ltd assumes no responsibility or liability for typographical errors or omissions or for any misinterpretation of the information within the publication and reserves the right to change without notice.