

This product is designed to meet the requirements of EN50131-2-6:2008
Security grade 2 , environmental class II



GP001/G2 Magnetic Surface Contact.

Surface mounted magnetic contact.
Heavy duty aluminium construction
Double pole configuration.
Suitable for domestic and commercial alarm circuits.
Can be used in installations up to and including grade 2.
Sealed to prevent tampering.

Operating and Installation Instructions

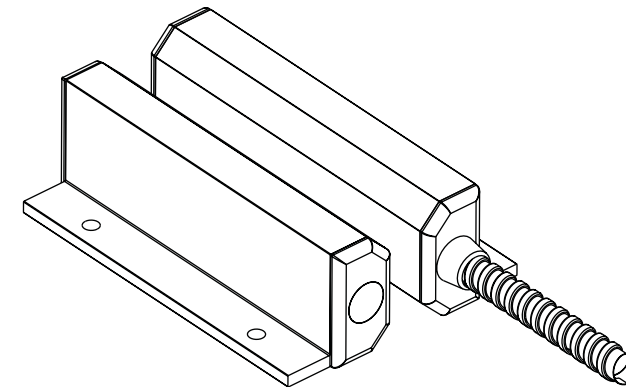

Description

This heavy duty surface mounted magnetic contact can be used in most security systems up to grade 2 as specified in EN50131-1: 2006 and is compliant with EN50131-2-6:2008 and environmental class II (for use indoors). It operates as a normally closed circuit going open when the magnet housing is moved away from the contact housing. This contact can be used on doors and windows to detect the unauthorised entry of an intruder. A number of applications are shown over. The contact is sealed to prevent access to inside of the unit.

CQR Security. 125, Pasture Road, Moreton, Wirral. CH46 4TH, United Kingdom
Tel: +44 (0) 151 606 9595 Support: +44 (0) 151 606 6311 email: info@cqr.co.uk Web <http://www.cqr.co.uk>

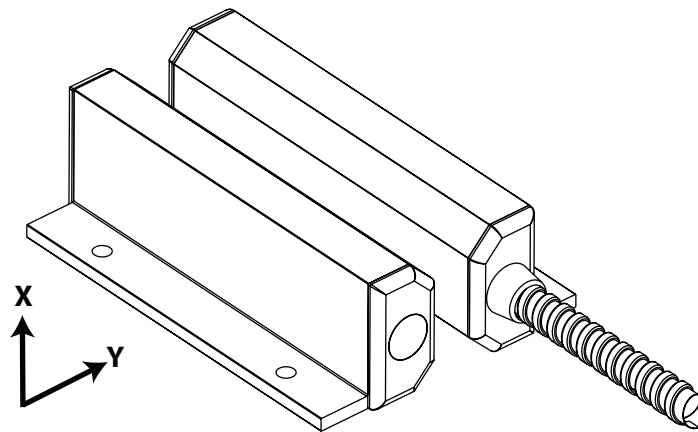

Approximate Operating Distances (mm) using Non Ferrous Surfaces

X	Min Close	45mm
	Max Open	95mm
Y	Min Close	40mm
	Max Open	110mm

Mounting on a ferrous surface will reduce these figures, dependant on the material and thickness.

Specifications

Switch		Housing	
Contact Material:	Rhodium	Material:	Aluminium/ABS
Cable :	7/0.2 Copper	Armoured Cable Length:	570mm
Contact Rating:	500mA @ 12Vdc	Contact Dimension (mm):	85 x 27 x 26
Contact Resistance:	100 milliOhms	Contact Fixing (mm):	50mm centres
Temperature Range:	-15° C to +40° C	Magnet Dimension (mm):	85 x 27 x 26
Life Expectancy:	>1,000,000 cycles	Magnet fixing (mm)	50 centres

Environmental Advice.

This product is covered by current WEEE regulations. Please consider the effect on the environment when disposing of it. Do not put in a domestic waste bin. Only dispose of at an appointed recycling centre.



RoHS compliant.

Features

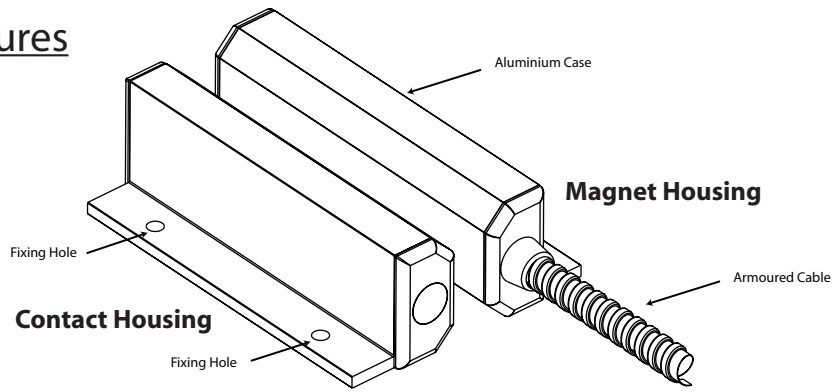

Suitable Applications and Fixing Points

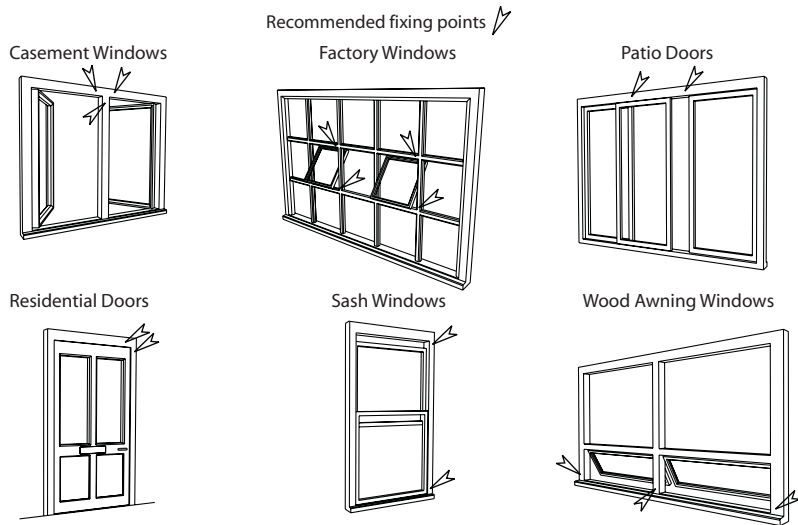

Mounting Instructions

Mount the contact housing using the fixing holes as shown in the diagram. Please see the mounting configurations to ensure that the contact is mounted in the most suitable location. Terminate the contact as shown in the diagrams using a suitable junction box that can isolate the spare wires from each other. We recommend the use of a JB707/WH as an ideal choice. Mark out the position of the magnet housing and secure in place with the screws provided.

Mounting Configurations

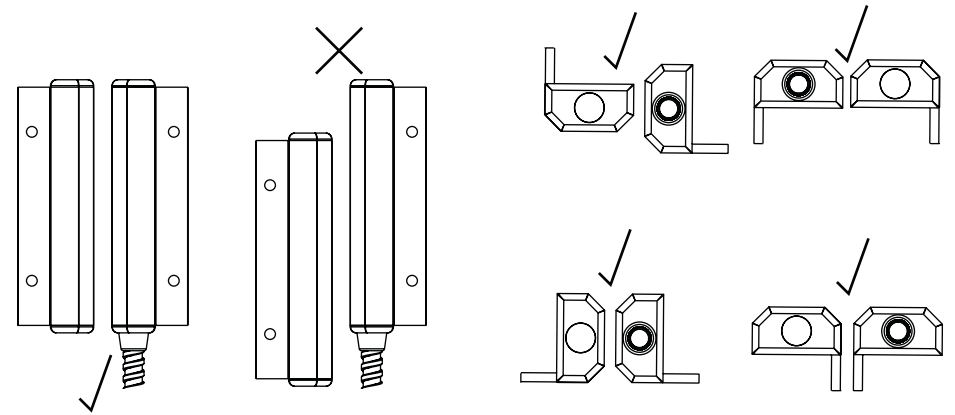

Wiring Configurations

SCHEMATIC 8 Wire GP001 G2

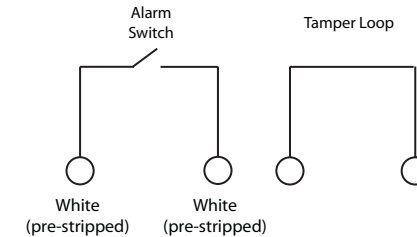

Wiring Options

