

Control panel types available on this model.

Type	Control Panel	Colour	Alarm	Tamper
A	Honeywell, Ademco Microtech	Green	1K	1K
B	Scantronic, Menver, Pyronix PCX (1.2, 2.2, 4.4, 1.28 VID), Texcom, Castle Caretech G3 Plus.	Red	4K7	2K2
D	DSC	Orange	5K6	5K6
F	Guardtec	Purple	6K8	4K7
E	Pyronix Matrix, PCX 5M5, 1.34, 2.56.	Varies	4K7	4K7

* Please note that type I (4K7, 4K7) is achieved by selecting the alarm link of type B and the tamper link of type E

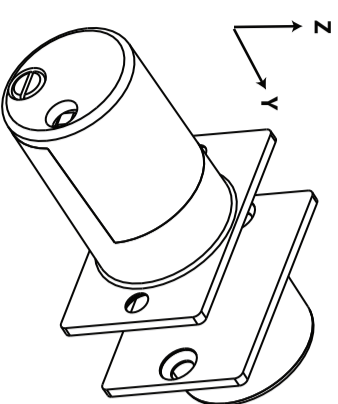

Aprox Operating Distances (mm)

Non Ferrous Surface		
Z	Min Close	3mm
	Max Open	10mm
Y	Min Close	4mm
	Max Open	12mm

Mounting on a ferrous surface will reduce these figures, dependant on the material and thickness.

Specifications	
Switch	Housing
Contact Material: Silver plated copper	Material: High Impact Polystyrene
Contact Rating: 500mA @ 12Vdc	Contact Dimension (mm): 33 x 22 x 3.2
Contact Resistance: 100 milliohms	Contact Fixing (mm): 26mm centres
Temperature Range: -15° C to +40° C	Magnet Dimension (mm): 33 x 22 x 13
Life Expectancy: up to 100,000 cycles	Magnet Fixing (mm): 26mm centres



* FC508*/MULTI/G3/EN denotes colour i.e. WH = White

This product is designed to meet the requirements of EN50131-2-6:2008 Grade 3, & Environmental class II

FC508*/MULTI/G3/EN

Operating and Installation Instructions

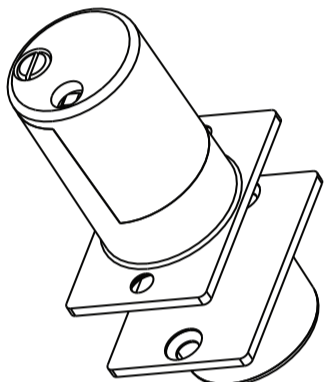

Description

This flush mounted magnetic door contact be used in most intruder alarm systems up to and including grade 3 as specified in EN50131-1:2006 and is certified to EN50131-2-6:2008 and environmental class II (for use indoors) by Telefication. It operates as a normally closed circuit going open when the magnet housing is moved away from the contact housing. This contact can be used on most doors to detect the unauthorised entry of an intruder. It has 4 terminals to allow for the selection of either double pole or EOL configuration and is suitable for use on double door applications, it is also immune to magnetic interference and is protected against tampering by lid removal.

CQR Security Ltd, 125, Pasture Road, Moreton, Wirral, CH46 4TH, United Kingdom

Tel: +44 (0) 151 606 1000 Support: +44 (0) 151 606 6311 email: info@cqr.co.uk Web http://www.cqr.co.uk



RoHS compliant.

Features

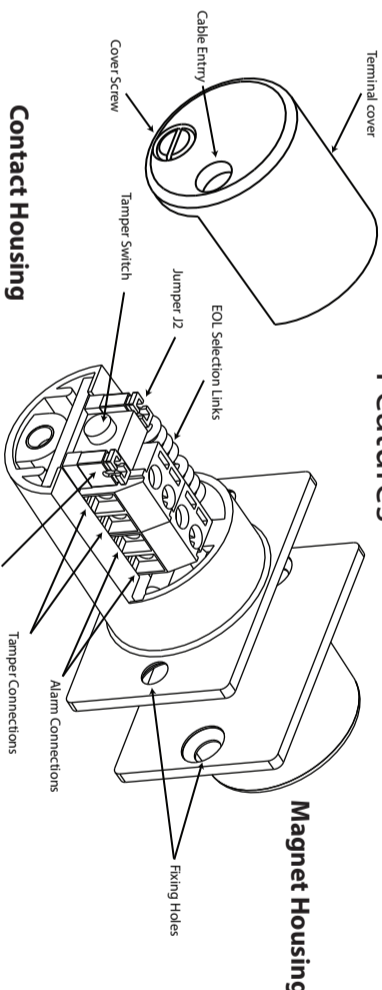

Suitable Applications and Fixing Points

Recommended fixing points
Residential and Commercial Doors

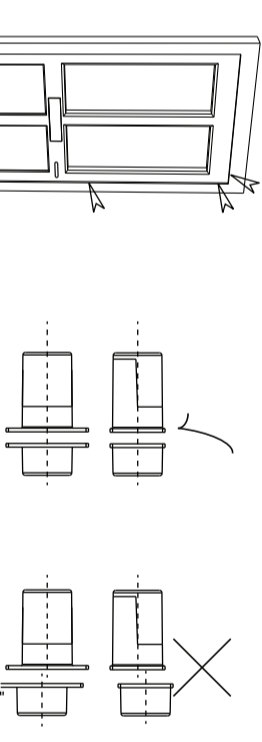

Mounting Instructions

To install the contact housing, drill a 20mm hole into the door frame to a minimum depth of 35mm on the opening side of the door. If the face plate is required to be flush, mark around the face plate and chisel out the wood to the required depth to allow the face plate to be flush with the surface.

Drill a suitable hole at the top of the already drilled 20mm hole to allow for cable entry and feed the cable through it. Remove the cover from the contact and feed the cable through it before terminating the wires referring to the drawings opposite. Refit the cover and insert the completed assembly into the prepared hole and secure with the screws provided. To fit the magnet, carefully mark the position on the door from the already fitted contact to ensure that the centre of the magnet is aligned with the centre of the contact. Drill a 20mm hole to a minimum depth of 15mm into the door, again mark and chisel out the wood if required for a flush fitting with the surface. Place the magnet casing into the hole and secure it using the screws provided.

Note: This contact uses opposing fields to operate a switch, it is advised to ensure that the closed door has a minimal amount of free play.

Wiring Configurations

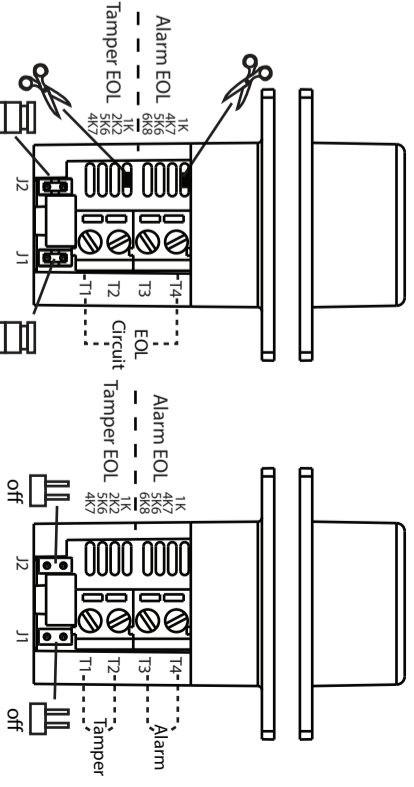

Fully Supervised (Panel type A illustrated)

Leave both Jumpers in place. Cut the appropriate resistor links (1K 1K illustrated). EOL Circuit T1 and T4

Double Pole

Remove Jumpers J1 and J2. Alarm Circuit T3 and T4. Tamper Circuit T1 and T2

Double Door Fully Supervised Connections. (Panel type B illustrated)

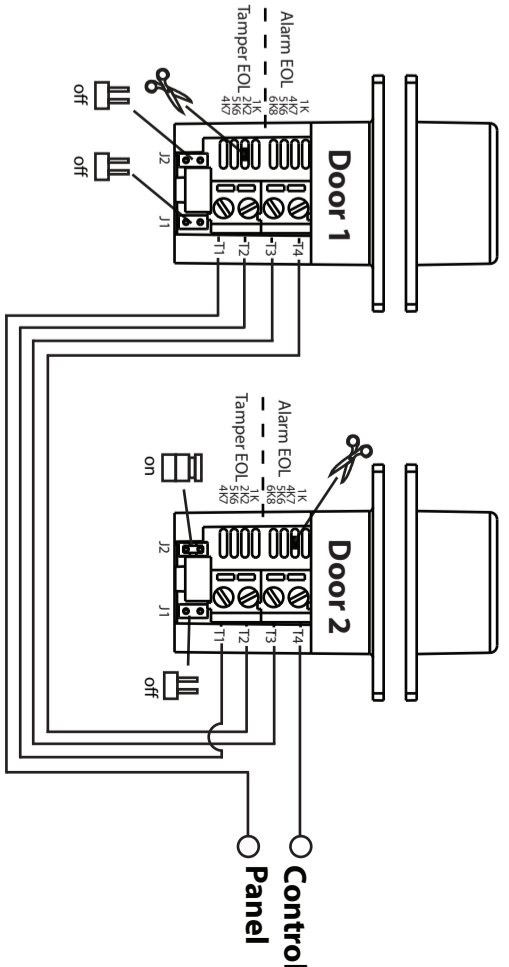

Door 1

Remove Jumpers J1 and J2. Cut appropriate tamper resistor link (2K2 illustrated). Connect T1 to panel

Interconnections

Connect T2 unit 1 to T1 unit 2. Connect T4 unit 1 to T2 unit 2 (4K7 illustrated). Do not cut any tamper resistor links. Connect T4 to panel

Door 2

Remove jumper J1 only. Cut the appropriate alarm resistor link (1K illustrated). Do not cut any tamper resistor links. Connect T4 to panel