

Lighting control module (LCM)



Ref WD812 issue 4



This device should be installed by a qualified electrician in accordance with the latest edition of the IEE wiring regulations.

POSITIONING

This device is designed to be ceiling-mounted.

1. Install devices in the position shown on the installation drawings where possible.
2. Always ensure that installation complies with relevant Building Regulations and that device wiring meets the requirements of the latest IEE Wiring Regulations (BS7671).
3. Fix the box on a smooth, flat surface or using drop rod fixings. You can use optional track fixings.
4. Ensure that there is easy access to the wiring compartment and all connectors once the box is in place. Allow 170mm for total height of installed unit including connectors and cable.
5. Ensure that LCMs face downwards and are clear of obstructions so that they are accessible and visible.

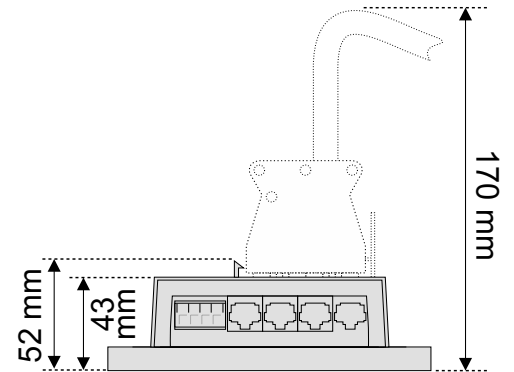
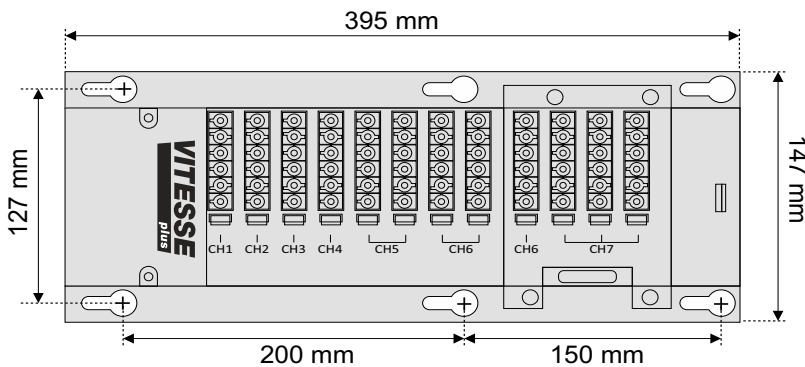
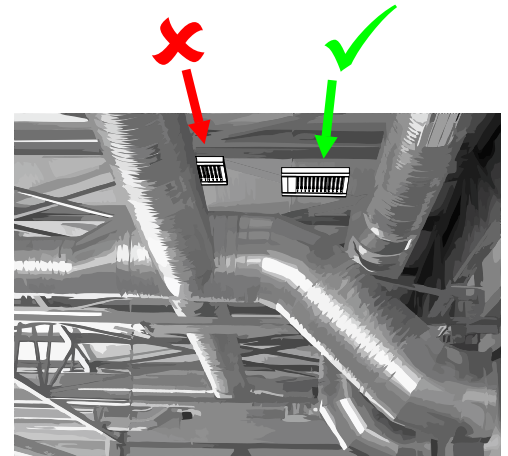

POWER CONNECTIONS

Make sure you connect the live terminal L to maintained live PL.

Letter	Colour	Description
L	Brown	Live/ phase
B	Blue	Neutral
E	Green/yellow	Earth/ground
PL	Brown or black	Permanent live

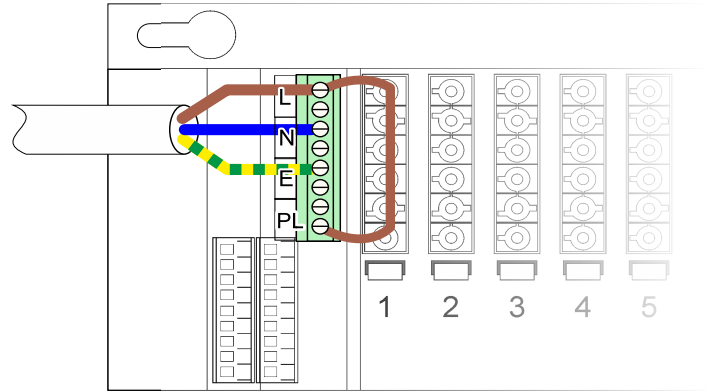

INRUSH CURRENT

Based on testing using Tridonic LCAI 10W 150 mA-400mA ECO C LED driver (Tridonic Article Number 28000130). Up to a maximum of 80A of Inrush current per output channel for no more than 10 mS.

The following **maximum** number of LED drivers can be connected to VITP7-MB and VITP7-MB-DD. Alternative LED drivers may have larger inrush and will need to be de-rated accordingly. Check with the luminaire manufacturer. **CP Electronics accept no responsibility for checking and applying suitable de-rating factors for LED loads.**

No more than 36 LED drivers per LCM.

Channels 1-4 = no more than 3 LED drivers each

Channels 5 = no more than 6 LED drivers (3 per output)

Channel 6 = no more than 9 LED drivers (3 per output)

Channel 7 = no more than 9 LED drivers (3 per output)

NB: if other channels are not used up to a maximum of 5 LED drivers may be connected to a single 6 pole output. This is as long as the electrical loading, Inrush rating and/or maximum LED driver allowance is not exceeded.

SWITCH CONNECTIONS

The LCM has 18 switch connections in the wiring compartment. Refer to the preset diagrams in the VITP7 system manual for details on how to connect switches.

The length of cable between switches and LCMs should not be more than 40 metres.

DETECTOR CONNECTIONS

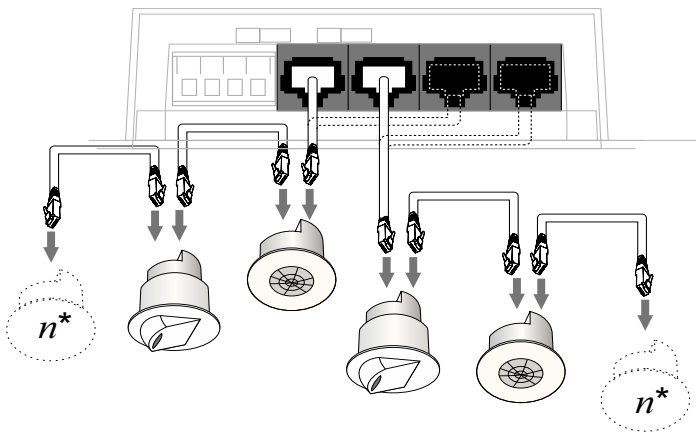

You must connect all detectors before programming the LCM.

Connect the detectors to each other using RJ45-RJ45 patch leads (part number EBS-PC5M).

* The power used by 1 microwave detector is the same as that used by 2 PIR detectors. These LCMs can supply power to a maximum of either 3 microwave detectors or 6 PIR detectors. You can connect combinations of microwave and PIR detectors, but this power limitation means that if you connect 1 microwave detector you can only have a maximum of 4 PIRs; if you have 2 microwave detectors you can have a maximum of 2 PIRs.

LUMINAIRE CONNECTIONS

You must use mains-rated cable with a minimum CSA of 0.5 mm².

Plug in the luminaires ensuring that the connector latches to the box (pre-wired luminaire leads are available - please contact our sales office for details).

For per-luminaire energy measurement connect one light fitting only per pluggable output.

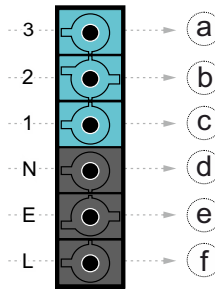
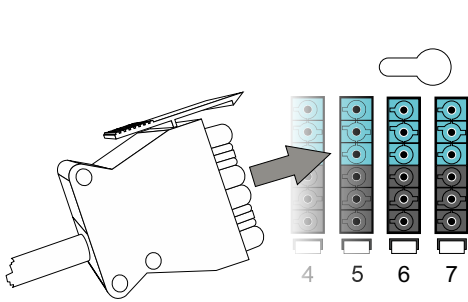

Letter	Colour	Description
a	Red	Dim +ve
b	White	Dim -ve
c	Black	Permanent live
d	Blue	Neutral
e	Green/yellow	Earth
f	Brown	Switched output

Dimming Luminaire

These connections are suitable for devices such as:

- DALI/DSI dimmable emergency luminaire
- Dimmable non-emergency luminaire
- 1-10V dimming luminaire, with or without emergency battery pack

6 core

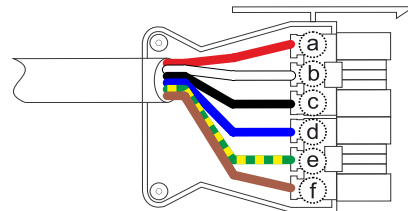

5 core

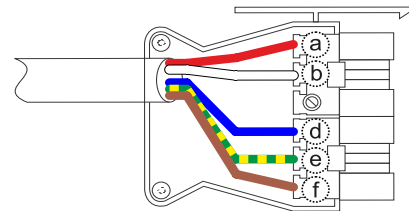

Key

- a. red
- b. white
- c. black
- d. blue
- e. green/yellow
- f. brown

Non-dimming Luminaire

These connections are suitable for devices such as:

- Non-dimmable ON/OFF emergency luminaire
- Non-dimmable non-emergency luminaire

4 core

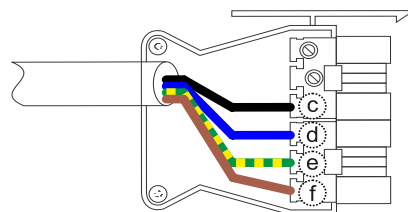

3 core

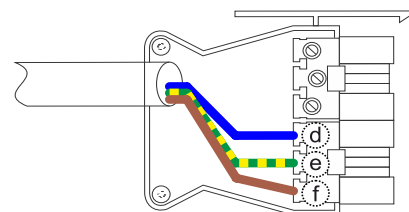

Key

- a. -
- b. -
- c. black
- d. blue
- e. green/yellow
- f. brown



For correct installation, connector plugs must be fully engaged and latched on both sides.

TECHNICAL DATA

Weight kg	1
Supply voltage AC at 50Hz	230 +/- 10%
Power consumption ON W	9.1
Power consumption OFF W	5.8
Terminal capacity	Mains 4mm ² ; switched inputs 1.5 mm ²
Max load (total for LCM - switching devices)	10 A
Max load (per channel - switching devices):	
- Incandescent lighting	6 A
- Fluorescent lighting	6 A
- Compact fluorescent lighting	3 A
- LED lighting	3 A
- Low voltage lighting (switch primary of transformer)	3 A
- Switch SON lighting loads via a contactor	
- Fans and ventilation equipment	3 A
Max load (total for LCM - dimming devices)	10A from up to 36 drivers / ballasts (see page 2 for inrush)
SELV	There are 3 isolated circuits supplied from an isolating safety transformer. SELV rated Logic power (relay drive, microcontroller, CAN bus) has a maximum voltage of 13V. SELV inputs have a maximum voltage of 5.5V. The Non SELV circuitry of the dimming outputs is 16V nominal and 22.5V maximum.
Insulation	Class II
Purpose	Operating control
Construction	Independent, surface mounted, electronic control
Type of action	Type 1.B action (micro disconnection)
Pollution	Degree 2
Software	Class A
Rated impulse voltage	2500 V
Operational temp. °C	-10 to 35
Humidity	5 to 95% non-condensing
Material (casing)	Flame retardant ABS and PC/ABS
IP rating	40
Compliance	EMC-2014/30/EU, LVD-2014/35/EU

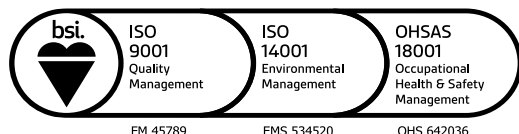

CP Electronics - a business unit of
 Legrand Electric Limited
 Brent Crescent, London NW10 7XR UK
 Tel: +44 (0)333 900 0671
 Fax: +44 (0)333 900 0674

A brand of **legrand**[®]
www.cpelectronics.co.uk
enquiry@cpelectronics.co.uk

Due to our policy of continual product improvement, CP Electronics reserves the right to alter the specification of this product without prior notice.

Ref WD812 issue 4