

SMOKESTOP™ evacU8®

ACTIVE SMOKE BARRIERS WITH EGRESS

WWW.COOPERSFIRE.COM



coopers

EST. 1983

LEADING THE WAY IN FIRE PROTECTION

evacU8®
THE WALKTHRU™ SMOKE BARRIER

SmokeStop™ evacU8® is a unique patented bi-roller system which has interweaving, overlapped panels as narrow as 600mm wide. Each panel overlaps the other and has its own self levelling bottom ballast system. Evacuees can simply 'WALKTHRU™' the panels which then fall back into place, helped by the patented anti-tangle overlap retention system. The evacU8® curtain is compliant with the Equality Act.

Active Smoke Barriers comprise technologically advanced fire-resistant fabric barriers encased in a compact steel housing. Barriers remain invisibly retracted until activated by an alarm or detector signal, at which time they descend safely to their fire operational position.

To be compliant, Smoke Barriers must be protected from a short circuit and or total power failure, this is achieved with our patented Total Gravity Fail-Safe (TGFS) system. Smoke Barriers will control the spread of smoke in a building and protect the means of escape and create tenable conditions.



WHY IS A WALKTHRU™ SMOKE BARRIER REQUIRED?

LIFE SAFETY

- The ever increasing need for tenable conditions for life safety

ESCAPE

- Provides an intuitive means of escape

COMPLIANT

- Equality Act compliant

PREVENTION

- Prevents smoke spreading, threatening life and buildings' contents

QUICK AND EASY

- Installation is quick and easy with minimal effort

HIGH OCCUPANCY

- Ideal for high occupancy evacuation of buildings when deployed

When activated, SmokeStop™ evacU8® descends at safe controlled speeds in accordance with the Machinery Directive. Evacuees can then approach the barrier quickly, safely and see if anyone is coming the other way. Approved escape signs can show which panels to pass through to avoid collision and tangling. When retracting, the combination of sequential ascent, the re-aligning panel system with the divide and separating bi-roller system ensures a trouble free operation.



PRODUCT ADVANTAGES

- Total Gravity Fail-Safe (TGFS) operation ensures safe rates of descent even following total power loss, wiring, short circuit or system corruption
- Anti-tangle, re-alignment and bi-roller overlapping system
- Self levelling bottom ballast system to overcome uneven floors
- See through panels are highly translucent for safety

- Unique strip retraction enables safe, consistent rewinding when ascending
- Unique mechanical over ride system for Emergency Services (Optional)
- Additional safety escape signage can be applied as directed

CASE STUDY:
YORK MINSTER

YORK UK

York Minster Revealed (YMR) is the UK's largest restoration and conservation project of its kind. This ambitious transformation of York Minsters visitor experience presented the Cathedral with a number of fire safety challenges that needed addressing prior to the opening of the Cathedrals below ground Undercroft and Treasury exhibition spaces.

Appointed architects Arrol & Snell assigned Coopers to develop a system that would help protect the Cathedral's Undercroft and Treasury from smoke migration in the event of a fire.

The smoke barrier system had to allow visitors to exit the Undercroft and Treasury safely, whilst preventing smoke from entering the main body of the Cathedral, but any system had to be sympathetic to its unique and ancient architecture.

To meet the criteria, Coopers produced and installed four SmokeStop™ evacU8® Smoke Barriers developed to work with the Undercroft's visitor flow and footfall, whilst a traditional SmokeStop™ Smoke Barrier was installed to compartmentalise the Chambers.

BENEFITS

- Manufactured by Coopers in the UK under ISO 9001;
- Products supplied are CE Marked in accordance with the Construction Products Regulations and are approved accredited under an Independent Third Party Certification scheme;
- Unique WALKTHRU™ curtain barrier technology; and
- Bespoke development and manufacture

"Coopers developed a unique smoke containment system that ensures our visitors are protected in the event of fire"

Mark Hosea, Director,
York Minster Revealed

THE BENEFITS OF evacU8® SMOKE BARRIER

- Small compact headbox - easily concealed
- Trouble free operation design features
- Unobtrusive remote controls
- Mechanical override (optional)

SmokeStop™ evacU8® uses a unique low opacity polymer coated glass fibre fabric for high performance impermeability, crease and abrasion resistance and translucency, which is 'A1' classified, the highest rating for reaction to fire classifications available in accordance with BS EN 13501-1+A1.

SmokeStop™ evacU8® is CE marked and tested to BS EN 12101-1+A1 and has achieved a D₆₀₀A classification to BS EN 13501-4+A1.

OPTIONS

The following options are available with the SmokeStop™ evacU8® system:

MECHANICAL OVERRIDE

- As an optional extra, the smoke barrier can be supplied with a manual override system designed to provide local, manual control of the smoke curtain's deployment and ascent.

The feature allows maintenance teams to turn off the power to the smoke barrier to conduct planned and necessary servicing or maintenance.

TRANSLUCENT FABRIC

- Allows escapees to see the other side of the escape route therefore being aware of any possible danger and removing the risk of injury.

SIGNAGE

- The fabric panels of the curtain can be easily printed onto displaying any necessary images such as fire escape signs, messages or company logos, where agreed by an approved authority.

ALARM SYSTEM

- Can be stand alone with an independent smoke and/or heat detector or connected to a building's existing fire alarm system.

BMS (Building Management System)

- The system can easily be incorporated into any Building Management System.

DEPLOYMENT OPTIONS

Standard Deployment



1

Full closure of alternate fabric panels creates clear escape routes

Multistage Deployment



2

Partial closure of all fabric panels provides initial smoke layer depth protection whilst allowing clear WALKTHRU™



3

Full closure of remaining fabric panels provides total smoke protection whilst still allowing WALKTHRU™



4

Full closure of remaining fabric panels provides total smoke protection whilst still allowing WALKTHRU™

Signage for illustration purposes only

SIZES

Standard Size Range Available (Metres)	Widths up to	Drops up to
Maximum Size	Unlimited	6.7m*

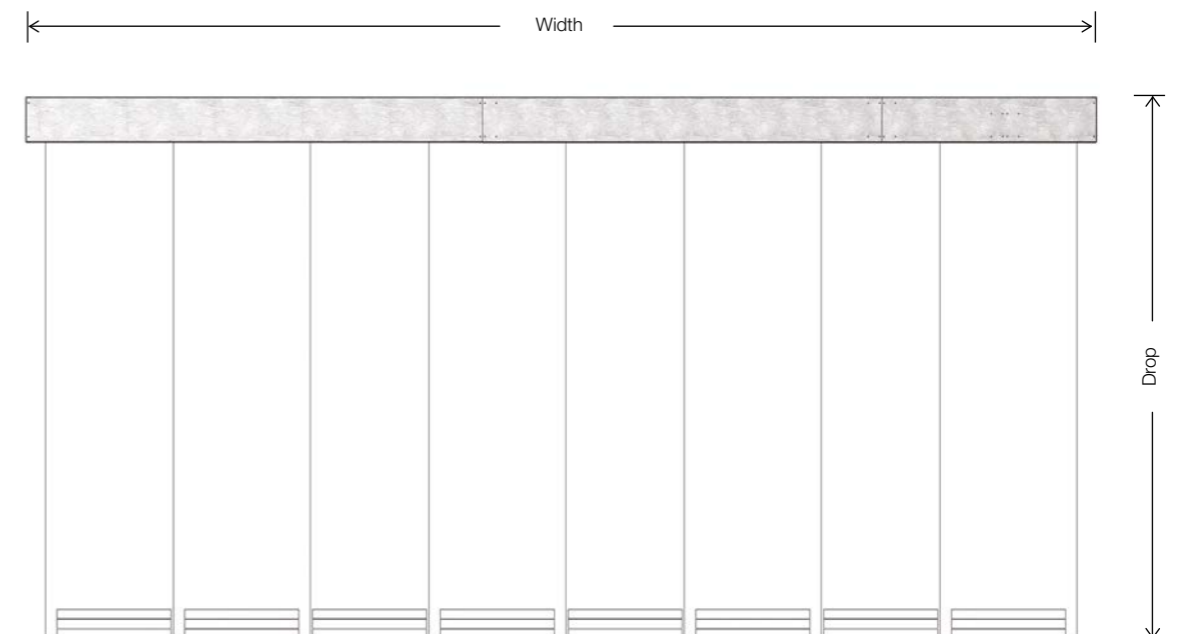

*Coopers has a design solution for any size requirement. Specific heights may increase panel width and overlap, please contact our technical department for further information.

ACCESS

Access for maintenance is always required through the bottom of the headbox along the entire width of the SmokeStop™ evacU8® barrier. This is achieved by removing the bottom panels on both sides of the headbox as illustrated below.

(Remember, regular service and maintenance is a legal mandatory requirement)

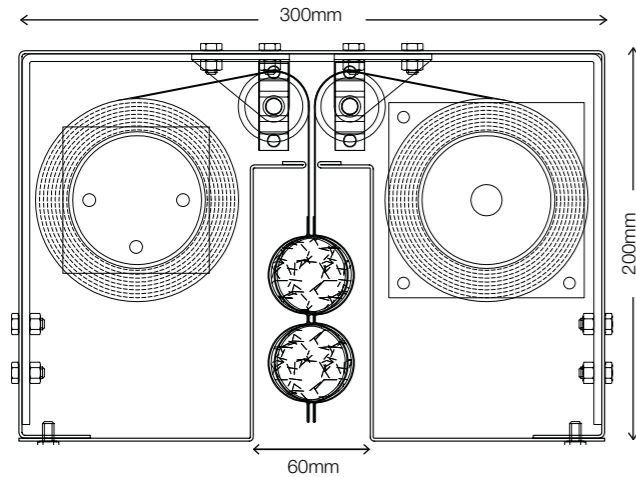

The maximum drop available from the headbox illustrated left is 4m.

For a drop between 4m and 6.7m a 350mm x 250mm headbox is required.

COMMON APPLICATIONS

- Underground Rail Stations
- Airports
- Stadiums
- Museums
- Office Blocks
- Cinemas
- Shopping Centres
- Libraries
- Universities
- Schools
- Hospitals
- Restaurants



CONTROL OPTIONS



PRODUCT SPECIFICATION

The complete system is CE Marked in accordance with the Construction Products Regulation (305/2011), as required by the CE Marking Directive (93/68/EEC), when tested in accordance with BS EN 12101-1+A1:2005. System is classified as D₆₀₀A in accordance with BS EN 13501-4:2007+A1:2009. The complete system is also classified to DA to BS ISO 21927-1:2008.

EFPTM 2/600/T is a tried and tested smoke fabric. The base fabric is glass fibre with a specially formulated low opacity and fire retardant polymer coating to allow some visible light to pass through.

The fabric is additionally tested to BS EN ISO 1716:2010 and is classified to 'A1' in accordance with BS EN 13501-1:2007+A1:2009. Fire propagation to BS 476 6:1989+A1:2009 and surface spread

of flame to BS 476-7:1997 to achieve National Class '0' in accordance with A13(b) Approved Document B 2006 Edition 'Fire Safety' to the Building Regulations 2000 England and Wales.

DON'T BE LIABLE

Smoke Barriers are legally required to be CE Marked under the Construction Products Regulation. They must be fail safe in the event of total mains, wiring, short circuit and/or system corruption.

Coopers Fire, with their unique patented Total Gravity Fail-Safe (TGFS) system, are the only supplier with Independent Third Party Certification by a UKAS approved certification body, and CE Marked as fully compliant with BS EN 12101-1:2005+A1:2006.

CONTROLS SPECIFICATION

POWER SUPPLY
230V AC 50Hz dedicated supply via all pole isolator

BATTERY BACK_UP
2 x 12V 7A/h lead acid batteries

ALARM SIGNAL
Normally closed volt-free contacts. Open on activation

TEST FACILITY
Zone Control Panel (ZCP) located on front of Power Supply Unit (PSU)

DISPLAY
Power ON, Alarm ACTIVE and Alarm OFF status LED's on ZCP

POWER SUPPLY UNIT -
Panel Size
400mm(w) x 500mm(h) x 210mm(d)



FM 22356

LQR 4007272



CPD ACCREDITATIONS



For information, to get a quote
or to book a CPD workshop

Please call:

+44 (0)2392 454 405

or E-mail: info@coopersfire.com

WWW.COOPERSFIRE.COM

Coopers Fire Ltd,
Edward House, Penner Road,
Havant, Hampshire, PO9 1QZ
United Kingdom

Phone: +44 (0)2392 454 405

Fax: +44 (0)2392 492 732

Email: info@coopersfire.com

Web: www.coopersfire.com

Coopers Fire Ltd has a policy of
continuous product improvement.

As such we reserve the right to
change design and specifications
without prior notice.

Please check our website for the
latest information

© Coopers Fire Ltd. All content and products are copyright
of Coopers Fire Ltd. Registered in England Number: 2010274.
Multiple patents granted and pending.



Series 2 v04 May 2015



LEADING THE WAY IN FIRE PROTECTION