

XP60 dual imager analogue series - UL range

PTZ camera station,
hazardous location



Overview

The Oxalis XP60 dual imager is an explosion protected PTZ camera station for use in hazardous areas in onshore, offshore, marine and heavy industrial environments. The dual imaging configuration of optical and thermal is used for continued vision in ultra-low light conditions, such as fog or smoke. The large format housing allows the installation of customised equipment (subject to conformity).

The camera housings are designed specifically for the Americas markets or where UL standards on Class and Division have been specified.

The base unit carries dual NPT cable entries with easy access for cable termination during installation as standard, maximising compatibility and ease of use with existing fixed conduit installations.

Our camera stations are designed and manufactured for longevity in harsh environments, require minimal maintenance and are fully certified to UL standards as required by OSHA in both safe and hazardous areas.

See separate datasheet for ATEX/IECEX & other zone certification ranges.

Features

- Class 1 Division 1 and Zone 1 certified
- Electro-polished 316L stainless steel on all welded assemblies
- Camera station window in toughened glass
- Pole or wall mounting options (see separate datasheets)
- NPT entries as standard
- 4 different size lens options
- 4 resolution/frequency rating options
- Various camera module options
- Options also available for IP, analogue, hybrid, IP over Coax and direct fibre out* - see specific data sheet
- Supply voltage options (24 VAC, 110 or 230 VAC, 50/60Hz)
- Certified temperature from -58°F to +158°F* (ranging from T4 - T6)
- IP66/67

*Model dependent



Certifications

UL C1/D1	Class I, Division 1, Groups B, C, D, T4A(T5 & T6 On Request) Class II, Division 1, Groups E, F, G IP67 Class 1 Zone 1 A Ex d IIB + Hydrogen T4 (T5 On Request)
----------	--

General arrangement drawing (dimensions in inches and mm)

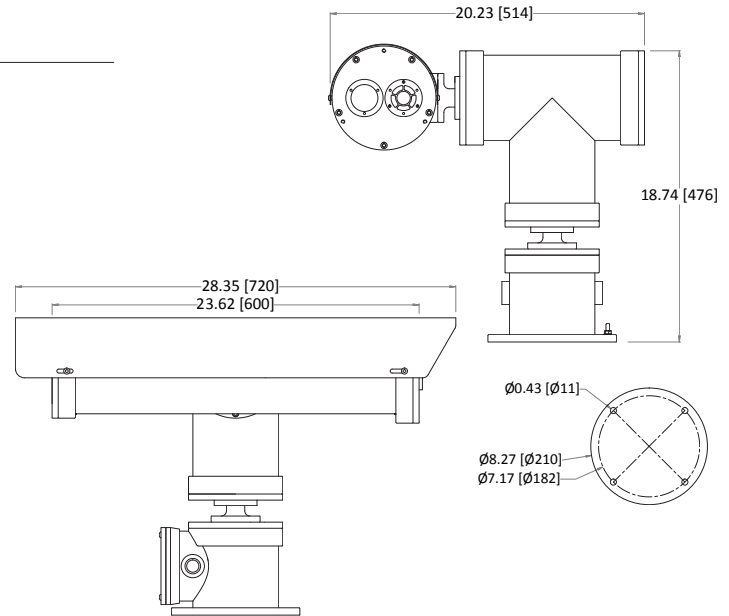

Specifications

Certification part number	P&T OXALIS-UL2420-01, Housing options OXALIS-UL2410-DI-00, 2410-DI-01		
Features		Electrical	
Sun shield	Standard stainless steel 316L mirror finish	Supply voltage options	24 VAC, 110 or 230 VAC, 50/60Hz
Integral wiper	Optional (silicone wiper blades that are resistant and do not perish after long exposure to ozone, UV, ice, snow, heat or cold)	Power consumption	85W maximum (143W with low temperature operation)
Integral demister	Standard	Electrical connections	Terminal block for power, data and video specific to camera configuration
Integral washer pump	Optional	Cable entry	2 x 3/4" NPT located in base
Washer systems	Compatible with Oxalis XW or XWP washer tanks (see separate datasheets)	Mechanical	
Pan speed (maximum)	45° per second	Body material	Electro-polished 316L stainless steel on all welded assemblies
Tilt speed (maximum)	24° per second	Fixings material	A4 stainless steel
Pre-set positional accuracy	64 presets: positional accuracy±0.1°	Camera station window	Toughened glass / Internal AR and external carbon coated germanium with protective grill
Telemetry receiver	Integral - Pelco D standard protocol (others to specification)	Mounting options	Pole or wall (see separate datasheets)
Rotation	Continuous pan or 350° rotation (+/- 175° from straight ahead)	Operating temperature	From -58°F to +158°F (model dependent)
Analogue direct fibre out	Optional singlemode 9/125µm or multimode 50/125µm video and data fibre optic transmission, mounted inside the camera station	Weight (lb)	Up to 126lb depending on configuration
Ingress protection rating	IP66/67	Type approval	DNV 2.4 2006 ABCD (copper transmission only)
Camera options			
1/4" CCD 36x zoom camera			
Image sensor	1/4" EXview HAD CCD (progressive scan)		
Resolution	High resolution mode on: 550 TV lines (default)		
Lens	36x zoom 3.4-122.4 mm F1.6 to F4.5, horizontal angle of view 57.8° -1.7°, 12X digital zoom, auto focus, auto iris		
Min. illumination	1/60 s, 1/50 s mode: 1.4 Lux, 1/4 s, 1/3 s mode: 0.1 Lux, 1/4 s, 1/3 s mode& ICR On: 0.01 Lux		
S/N ratio	>50dB		
Features	ATW, day & night auto/colour / BW (IR-Cut filter removable), camera title ON/OFF		
Thermal core module options			
T320 7.5-8.3Hz	Uncooled VOx microbolometer thermal imaging camera, including TCI Interface PCB for functionality over standard RS485 protocol Commands 324 x 256 resolution, 25µ pixel size, 7.5Hz NTSC/8.3Hz PAL exportable frame rate, digital detail enhancement		
T640 7.5-8.3Hz	Uncooled VOx microbolometer thermal imaging camera, including TCI Interface PCB for functionality over standard RS485 protocol Commands 640 x 512 resolution (PAL), 17µ pixel size, 7.5Hz NTSC/8.3Hz PAL exportable frame rate, digital detail enhancement		
T320 25-30Hz	Uncooled VOx microbolometer thermal imaging camera, including TCI Interface PCB for functionality over standard RS485 protocol Commands 324 x 256 resolution, 25µ pixel size, 30Hz NTSC/25Hz PAL frame rate, digital detail enhancement. Subject to export restrictions and licensing		
T640 25-30Hz	Uncooled VOx microbolometer thermal imaging camera, including TCI Interface PCB for functionality over standard RS485 protocol Commands 640 x 512 resolution (PAL), 17µ pixel size, 30Hz NTSC/25Hz PAL frame rate, digital detail enhancement. Subject to export restrictions and licensing		
Thermal core lens options			
19mm lens	FoV 24° x 18° (324 x 256) / FoV 32° x 26° (640 x 512). Detection of object 4m x 1.5m: 1280m (324 x 256) / 1550m (640 x 512)		
25mm lens	FoV 18° x 14°(324 x 256) / FoV 25° x 20° (640 x 512). Detection of object 4m x 1.5m: 1650m (324 x 256) / 2200m (640 x 512)		
35mm lens	FoV 13° x 10° (324 x 256) / FoV 18° x 14° (640 x 512). Detection of object 4m x 1.5m: 2250m (324 x 256) / 3000m (640 x 512)		
50mm lens	FoV 9.1° x 6.9°(324 x 256) / FoV 12.4° x 9.9° (640 x 512). Detection of object 4m x 1.5m: 3100m (324 x 256) / 3900m (640 x 512)		

Ordering requirements

The following code is designed to help in selection of the correct unit. Build up the reference number by inserting the code for each component into the appropriate box

XP60														
------	--	--	--	--	--	--	--	--	--	--	--	--	--	--

Housing type	Code
Dual imaging housing	D
Dual imaging housing with integral washer pump	Q

Wiper options	Code
Integral wiper with switched 24VAC for external washer pump	E
Integral wiper	W
No wiper	N

Video type	Code
Analogue video	I

Day/night module	Code
1/4" CCD 36x zoom camera	4

Thermal core module	Code
T320 7.5-8.3Hz	1
T640 7.5-8.3Hz	2
T320 25-30Hz	3
T640 25-30Hz	4

Thermal core lens	Code
19mm lens	1
25mm lens	2
35mm lens	3
50mm lens	4

Video system	Code
PAL	P
NTSC	N

Transmission type	Code
Standard electrical	0
Simplex singlemode 9/125µm video/data	1
Simplex multimode 50/125µm video/data	2
Customer specific transmission device	C

Temperature type	Code
T4A -4°F to +158°F	E
T4A -58°F to +158°F	F
T6 -4°F to +122°F*	G
T6 -58°F to +122°F*	H

*Subject to restrictions

Certification	Code
UL Class I Div I	L

Protocol requirements	Code
Pelco D protocol, baud rate 2400bps	D
Special - price on application	S

Camera rotation	Code
Continuous rotation	1
Pan rotation restricted to +/- 175°	2

Supply voltage	Code
24 VAC ±10% 50/60 Hz	1
110 VAC ±10% 50/60 Hz	2
230 VAC ±10% 50/60 Hz	3
Special - price on application	S