

# XP60 thermal image analogue series - UL range

PTZ camera station,  
hazardous location



## Overview

The Oxalis XP60 thermal imager is an explosion protected PTZ camera station for use in hazardous areas in onshore, offshore, marine and heavy industrial environments where thermal imaging is required for specific process or security applications. The large format housing allows the installation of customised equipment (subject to conformity).

The camera housings are designed specifically for the Americas markets or where UL standards on Class and Division have been specified.

The base unit carries dual NPT cable entries with easy access for cable termination during installation as standard, maximising compatibility and ease of use with existing fixed conduit installations.

Our camera stations are designed and manufactured for longevity in harsh environments, require minimal maintenance and are fully certified to UL standards as required by OSHA in both safe and hazardous areas.

See separate datasheet for ATEX/IECEX & other zone certification ranges.

## Features

- Class 1 Division 1 and Zone 1 certified
- Electro-polished 316L stainless steel on all welded assemblies
- Camera station window in toughened glass
- Pole or wall mounting options (see separate datasheets)
- NPT entries as standard
- 5 different size lens options
- 4 resolution/frequency rating options
- Various camera module options
- Options also available for IP, analogue, hybrid, IP over Coax and direct fibre out\* - see specific data sheet
- Supply voltage options (24 VAC, 110 or 230 VAC, 50/60Hz)
- Certified temperature from -58°F to +158°F\* (ranging from T4 - T6)
- IP66/67

\*Model dependent

## Certifications

UL C1/D1	Class I, Division 1, Groups B, C, D, T4A(T5 & T6 On Request) Class II, Division 1, Groups E, F, G IP67 Class 1 Zone 1 A Ex d IIB + Hydrogen T4 (T5 On Request)
----------	--

## General arrangement drawing (dimensions in inches and mm)

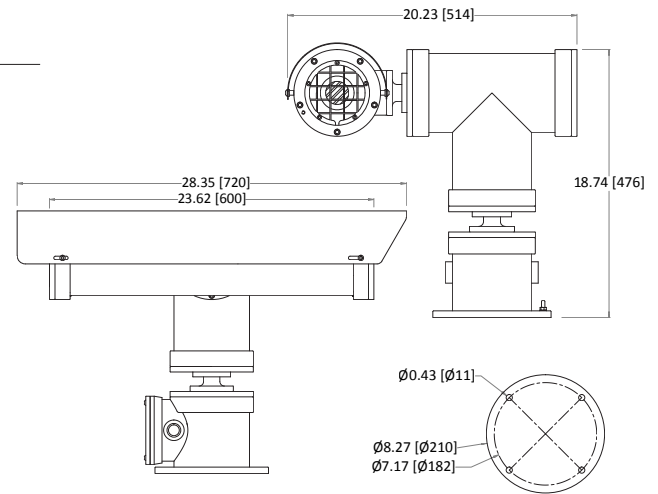

## Specifications

**Certification part number** P&T OXALIS-UL2420-01, housing options OXALIS-UL2410-TI-50, 2410-TI

### Features

**Sun shield** Standard stainless steel 316L mirror finish

**Integral demister** Standard

**Pan speed (maximum)** 45° per second

**Tilt speed (maximum)** 24° per second

**Pre-set positional accuracy** 64 presets: positional accuracy  $\pm 0.1^\circ$

**Telemetry receiver** Integral - Pelco D, P standard protocols (others to specification)

**Rotation** Continuous pan or 350° rotation (+/- 175° from straight ahead)

**Analogue direct fibre out** Optional singlemode 9/125 $\mu$ m or multimode 50/125 $\mu$ m video and data fibre optic transmission, mounted inside the camera station

### Electrical

**Supply voltage options** 24 VAC, 110 or 230 VAC, 50/60Hz

**Power consumption** 85W Maximum (143W with low temperature operation)

**Electrical connections** Terminal block for power, data and video specific to camera configuration

**Cable entry** 2 x 3/4" NPT located in base

### Mechanical

**Body material** Electro-polished 316L stainless steel on all welded assemblies

**Fixings material** A4 stainless steel

**Camera station window** Internal AR and external carbon coated germanium (50 or 102mm Ø) with protective grill

**Mounting options** Pole or wall (see separate datasheets)

**Operating temperature** From -58°F to +158°F (model dependent)

**Weight (lb)** Up to 126lb depending on configuration

**Ingress protection rating** IP66/67

### Approvals

**Type approval** DNV 2.4 2006 ABCD (copper transmission only)

### Thermal core module options

**T320 7.5-8.3Hz** Uncooled VOx microbolometer thermal imaging camera, including TCI Interface PCB for functionality over standard RS485 protocol Commands. 324 x 256 resolution, 25 $\mu$  pixel size, 7.5Hz NTSC/8.3Hz PAL exportable frame rate, digital detail enhancement

**T640 7.5-8.3Hz** Uncooled VOx microbolometer thermal imaging camera, including TCI Interface PCB for functionality over standard RS485 protocol Commands. 640 x 512 resolution (PAL), 17 $\mu$  pixel size, 7.5Hz NTSC/8.3Hz PAL exportable frame rate, digital detail enhancement

**T320 25-30Hz** Uncooled VOx microbolometer thermal imaging camera, including TCI Interface PCB for functionality over standard RS485 protocol Commands. 324 x 256 resolution, 25 $\mu$  pixel size, 30Hz NTSC/25Hz PAL frame rate, digital detail enhancement. Subject to export restrictions and licensing

**T640 25-30Hz** Uncooled VOx microbolometer thermal imaging camera, including TCI Interface PCB for functionality over standard RS485 protocol Commands. 640 x 512 resolution (PAL), 17 $\mu$  pixel size, 30Hz NTSC/25Hz PAL frame rate, digital detail enhancement. Subject to export restrictions and licensing

### Thermal core lens options

**19mm lens** FoV 24° x 18° (324 x 256) / FoV 32° x 26° (640 x 512). Detection of object 4m x 1.5m: 1280m (324 x 256) / 1550m (640 x 512)

**25mm lens** FoV 18° x 14° (324 x 256) / FoV 25° x 20° (640 x 512). Detection of object 4m x 1.5m: 1650m (324 x 256) / 2200m (640 x 512)

**35mm lens** FoV 13° x 10° (324 x 256) / FoV 18° x 14° (640 x 512). Detection of object 4m x 1.5m: 2250m (324 x 256) / 3000m (640 x 512)

**50mm lens** FoV 9.1° x 6.9° (324 x 256) / FoV 12.4° x 9.9° (640 x 512). Detection of object 4m x 1.5m: 3100m (324 x 256) / 3900m (640 x 512)

**100mm lens** FoV 4.6° x 3.4° (324 x 256) / FoV 6.2° x 5.0° (640 x 512). Detection of object 4m x 1.5m: 5300m (324 x 256) / 6000m (640 x 512) Ø102 Germanium housings only

# Ordering requirements

The following code is designed to help in selection of the correct unit. Build up the reference number by inserting the code for each component into the appropriate box

XP60													
------	--	--	--	--	--	--	--	--	--	--	--	--	--

Housing type	Code
Thermal imaging housing with 50mm germanium window	T
Thermal imaging housing with 102mm germanium window no camera	H

Transmission type	Code
Standard electrical	0
Simplex singlemode 9/125µm video/data	1
Simplex multimode 50/125µm video/data	2
Customer specific transmission device	C

Wiper options	Code
No wiper	N

Temperature type	Code
T4A -4°F to +158°F	E
T4A -58°F to +158°F	F
T6 -4°F to +122°F*	G
T6 -58°F to +122°F*	H

\*Subject to restrictions

Video type	Code
Analogue video	I

Certification	Code
UL Class I Div I	L

Day/night module	Code
No D/N camera fitted	N

Thermal core module	Code
T320 7.5-8.3Hz	1
T640 7.5-8.3Hz	2
T320 25-30Hz	3
T640 25-30Hz	4
Customer specific thermal camera	C

Protocol requirements	Code
Pelco D protocol, baud rate 2400bps	D
Pelco P protocol, baud rate 4800bps	P
Vicon protocol, baud rate 4800bps	V
HERNIS™ protocol	H
Coe protocol	C
Special - price on application	S
No control protocol	N

Thermal core lens	Code
19mm lens	1
25mm lens	2
35mm lens	3
50mm lens	4
100mm lens	5
Customer specific thermal imaging lens	C

Camera rotation	Code
Continuous rotation	1
Pan rotation restricted to +/- 175°	2

Supply voltage	Code
24 VAC ±10% 50/60 Hz	1
110 VAC ±10% 50/60 Hz	2
230 VAC ±10% 50/60 Hz	3
Special - price on application	S

Video system	Code
PAL	P
NTSC	N