

XP40 day/night analogue series

Explosion proof PTZ
camera station



Overview

The Oxalis XP40 is an explosion protected PTZ camera station for use in hazardous areas in onshore, offshore, marine and heavy industrial environments. The camera stations are designed for longevity in harsh environments with minimal maintenance.

Features

- ATEX, IECEx, Class 1 Division 1 and Zone 1 certified
 - Electro-polished 316L stainless steel on all welded assemblies
 - Camera station window in toughened glass
 - Pole or wall mounting options (see separate datasheets)
 - Supply voltage options (24 VAC, 110 or 230 VAC, 50/60Hz)
 - Operating temperature from -60°C to +70°C*
 - IP66/67
- *Model dependent



Certifications

ATEX	II 2 G Ex db (op pr) IIC T4 (T5 & T6 On Request)Gb II 2 D Ex tb (op pr) IIIC T135°C Db IP6x Certificate Number: ITS16ATEX101021X
IECEX	Ex db (op pr) IIC T4 (T5 & T6 On Request)Gb Ex tb (op pr) IIIC T135°C Db IP6x Certificate Number:IECEX ITS 15.0068X
INMETRO	Ex d IIC T4 (T5 On Request) Gb -60° C ≤Ta ≤+60°C Ex tb IIIC T135° C Db IP66/67. Certificate Number: TUV 12.1080X / TUV 12.1081X
LCus CI/ZI	Class I Zone 1 A Ex d IIC T4 (T5 On Request) LC13A11396 Gb -60° C ≤Ta ≤+60° C. UL 60079-0:2009 & 60079-1:2009 Certificate Number: 11396-1S-UL
cLCus CI/DI	Class I, Division 1, Groups B, C, D, -60° C ≤Ta ≤+60°C T4/ Class II, Division 1, Groups E, F, G IP67. CSA-C22.2 No:30-M1986 No:25-1966(R2009) CSA-C22.2 No:60065-03(R2012) & UL1203,UL60065(ED.7) Certificate Number: 11671-1S / 11677-1S
cLC CSA	Ex d IIC T4 (T5 On Request) LC1311396 -60° C ≤Ta ≤+60°C. CAN CSA-C22.2 No.60079-0:2011 & 60079-1:2011 Certificate Number: 11396-1S-CSA
TR CU GOST	IEEx d IIC T4X (T5 & T6 On Request) -60° C ≤Ta ≤+60° C Ex tb IIIC T135° C Db IP67. Certificate Number: TCRUGB.ГБ.В00318
CCOE	Ex d IIC (T5 & T6 On Request) -60° C ≤Ta ≤+60° C Gb Ex tb IIIC T130° C Db IP6x Certificate Number: F306928/1/2
CNEX	Ex d IIC T4/T5/T6 GB / Ex tb IIIC 135° C Db IP6X. Certificate Number: 132.2980X / 13.2981X
CERTEX	II 2 G Ex d (op pr) IIC T4 (T5 & T6 On Request) II 2 D Ex tb IIIC T135° C Db IP6x. Certificate Number: S-XPL-14.1340X

General arrangement drawing (all dimensions in mm)

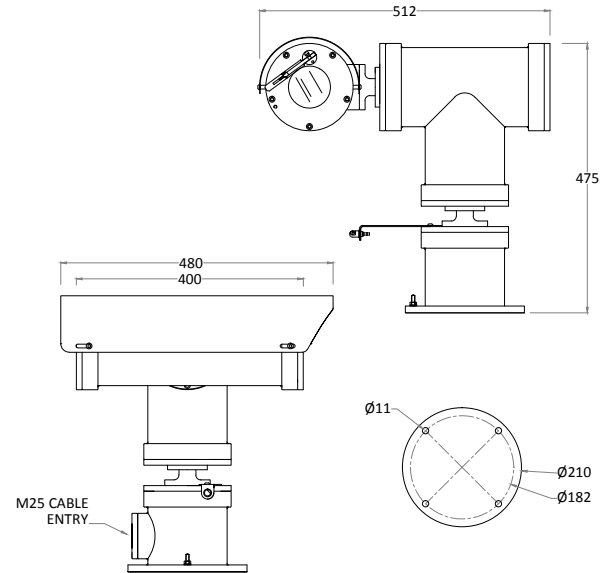

Specifications

Certification part number	P&T 2420-01, housing options 2410-03, 1410-25, 1410-10		
Features		Electrical	
Sun shield	Standard stainless steel 316L mirror finish	Supply voltage options	24 VAC, 110 or 230 VAC, 50/60Hz
Integral wiper	Optional (silicone wiper blades that are resistant and do not perish after long exposure to ozone, UV, ice, snow, heat or cold)	Power consumption	85W Maximum (143W with low temperature operation)
Integral demister	Standard	Electrical connections	Terminal block for power, data and video specific to camera configuration
Integral washer pump	Optional	Cable entry	Single M25 entry located in base
Washer systems	Compatible with Oxalis XW or XWIP washer tanks (see separate datasheets)	Mechanical	
Pan speed (maximum)	45° per second	Body material	Electro-polished 316L stainless steel on all welded assemblies
Tilt speed (maximum)	24° per second	Fixings material	A4 stainless steel
Pre-set positional accuracy	64 presets: positional accuracy ±0.1°	Camera station window	Toughened glass
Telemetry receiver	Integral - Pelco D, P standard protocols (others to specification)	Mounting options	Pole or wall (see separate datasheets)
Rotation	Continuous pan or 350° rotation (+/- 175° from straight ahead)	Operating temperature	From -60°C to +70°C (model dependent)
Analogue direct fibre out	Optional singlemode 9/125µm or multimode 50/125µm video and data fibre optic transmission, mounted inside the camera station	Weight (Kg)	Up to 53 Kg depending on configuration
Ingress protection rating	IP66/67	Type approval	DNV 2.4 2006 ABCD (Copper transmission only)
Camera options			
1/4" CCD 37x zoom camera			
Image sensor	1/4" super HAD CCD		
Resolution	Colour : 650 TV lines / B/W : 680 TV lines		
Lens	37x zoom 3.5-129.5 mm F1.6 to F3.9, horizontal angle of view 55.5°-159°, 16X digital zoom, auto focus, auto iris		
Min. illumination	Colour 0.7 lux (wide, 50 IRE@F1.6), 0.002 lux (sens-up, 256X super low light mode) B/W 0.03 lux (wide, 50 IRE@F1.6), 0.0001 lux (sens-up, 256X super low light mode)		
S/N ratio	>50dB		
Features	ATW, WDR, BLC, day & night auto/colour / BW (IR-Cut filter removable), camera title ON/OFF		
1/3" CCD 10x zoom camera			
Image sensor	1/3" EXview HAD CCD II (interlace scan)		
Resolution	High resolution mode on: 530 TV lines (default)		
Lens	10x zoom 5.1-51.0 mm F1.8 to F2.1 horizontal angle of view 52.0° - 5.4°, 12X digital zoom, auto focus, auto iris		
Min. illumination	1/60 s, 1/50 s mode: 0.25 Lux (F1.8, 50IRE), 1/4 s, 1/3 s mode: 0.015 Lux (F1.8, 50IRE) 1/4 s, 1/3 s mode & ICR On: 0.0004 Lux (typical) (F1.8, 50IRE)		
S/N ratio	>50dB		
Features	ATW, day & night auto/colour / BW (IR-Cut filter removable), camera title ON/OFF		
1/4" CCD 36x zoom camera			
Image sensor	1/4" EXview HAD CCD (progressive scan)		
Resolution	High resolution mode on: 550 TV lines (default)		
Lens	36x zoom 3.4-122.4 mm F1.6 to F4.5, horizontal angle of view 57.8° - 1.7°, 12X digital zoom, auto focus, auto iris		
Min. illumination	1/60 s, 1/50 s mode: 1.4 Lux, 1/4 s, 1/3 s mode: 0.1 Lux, 1/4 s, 1/3 s mode & ICR On: 0.01 Lux		
S/N ratio	>50dB		
Features	ATW, day & night auto/colour / BW (IR-Cut filter removable), camera title ON/OFF		

Ordering requirements

The following code is designed to help in selection of the correct unit. Build up the reference number by inserting the code for each component into the appropriate box

