

# CMSDANSKIN

## ACOUSTICS



The SuperPhon® Range provides an effective means of controlling reverberation and reflected sound in rooms. It provides an ideal solution for environments and workplaces where noise can be an issue.

SuperPhon® is used widely in:

- Recording studios
- Sports halls
- Schools
- Call centres

**Need a  
bespoke  
solution?  
Call for  
advice**

[www.cmsdanskin.co.uk](http://www.cmsdanskin.co.uk)

For further details please ring  
**Central/Southern: 01925 577711**  
**Scotland: 01698 356000**  
 or email [info@cmsdanskin.co.uk](mailto:info@cmsdanskin.co.uk)

# SuperPhon® Installation

CMS Dansk can provide a range of fixing systems for all applications. Below is a general guide to the most popular fixings. Bespoke fixing systems are available; call our technical department for more information.

## Fixing Plates for Wall Panels

Suitable for High Impact and standard wall panels.

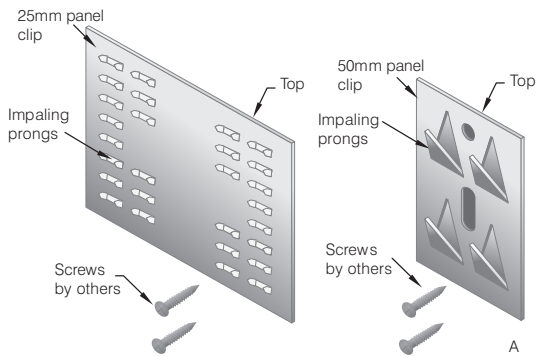

A

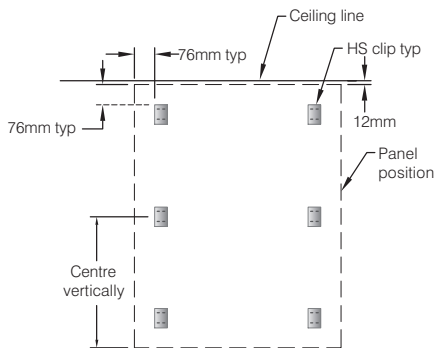

B

Clip placement is approximate  
NOTE: See chart for typ number of clips per panel

\*Construction adhesive recommended

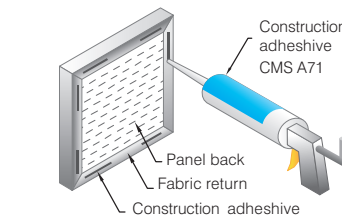

C \*(Adhesive to be applied to fabric return only)

- Determine where panels are to be installed (allow 12mm gap between panel and ceiling)
- Screw HS clips into place on wall per detail B and clip chart below
- Clean wall surface and apply construction adhesive to panel back as shown in detail C (adhesive to be applied to fabric return ONLY)
- Position panel approximately 12mm higher than desired panel resting position and impale panel onto clips with a downward motion

50mm Panels		25mm Panels	
Panel length (mm)	No. of clips	Panel length (mm)	No. of clips
Up to 610	4	1000	4
610 to 1200	4	1500	6
1200 to 1500	4	All other sizes	8
1800 to 2400	6		
2400 to 3000	8		

NOTE: Impaling prongs may be bent further to eliminate the gap (construction adhesive MUST be used when prongs are adjusted)

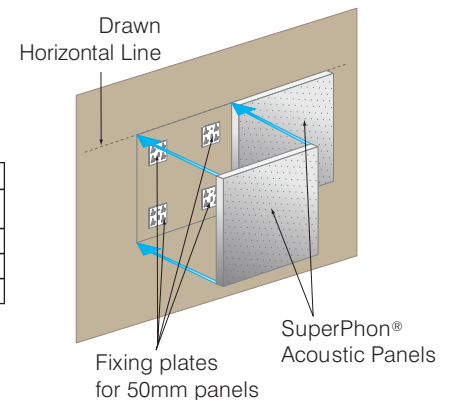
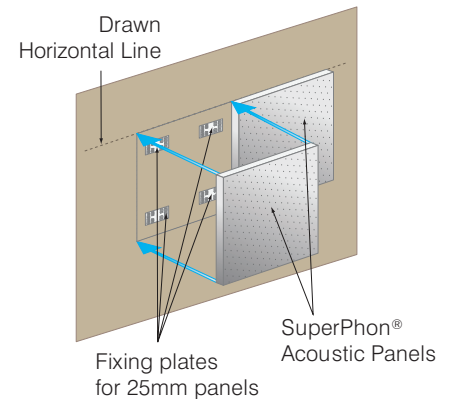

1000mm x 1000mm panels shown

## SuperPhon® Installation continued

### Rotofast Snap-On Anchors for Wall/Ceiling Panels

Suitable for High Impact and standard wall panels.

Rotofast Snap-On Anchors are a secure and fast solution for acoustic panel installation. For ceilings or walls, the Rotofast Snap On Anchor is the answer.



#### Rotofast Snap-On parts

Everything you need to install a panel in 5 easy steps



**1** Screw Rotofast Snap-On Anchors into the back of the panel using the Rotofast driver tool.

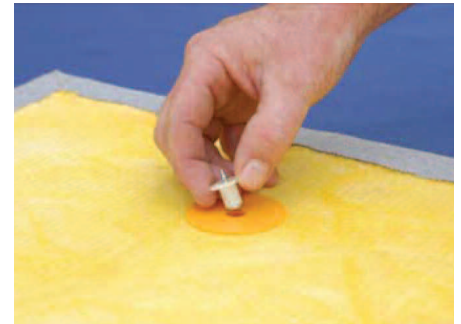

**2** Insert marking plugs into the Snap-On Anchors.



**3** Push panel against wall to mark anchor locations.



**4** Screw ratchets to wall at marked locations (#8 screws recommended). Plugs in the wall are recommended if studs cannot be picked up.



**5** Firmly push panel onto ratchets to complete installation.

## SuperPhon® Installation continued

### Rotofast Cloud Anchors for Ceiling Panels

Installing panels in cloud applications is done easily on site. Simply screw Rotofast Cloud Anchors into the back of the panel for a strong and secure installation.

Rotofast Cloud Anchors have been tested to have a pull-out strength of approximately 17kg in 64kg/m<sup>3</sup> acoustic insulation. This testing was conducted using samples from all the major acoustic insulation manufacturers.

Site conditions or panel size could affect the number of fasteners required. If unsure contact CMS Danskin technical department.

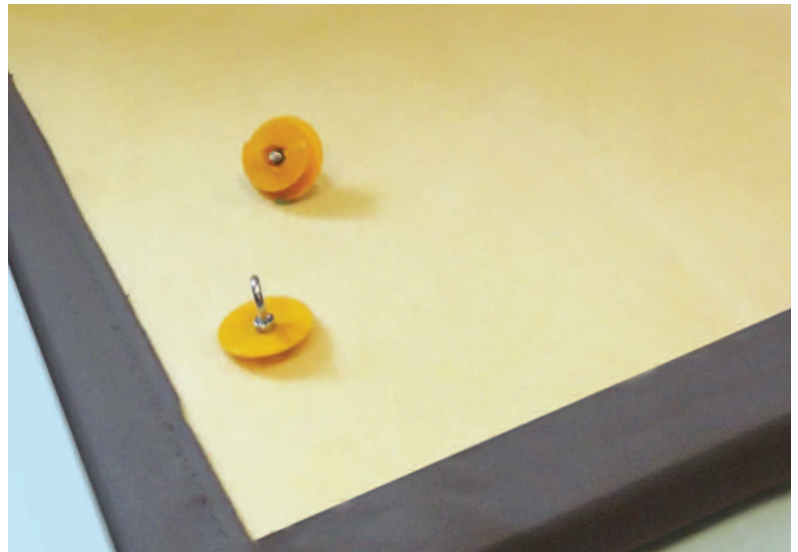

# SuperPhon® Installation continued

## Velcro Fixings suitable for Standard Wall Panels only

Velcro fixings are recommended where removable panels are required for access only.

### Rear of panel

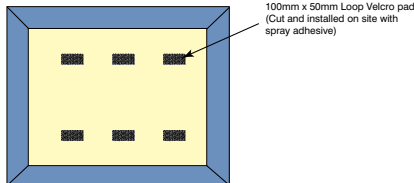

### Panel installation on wall

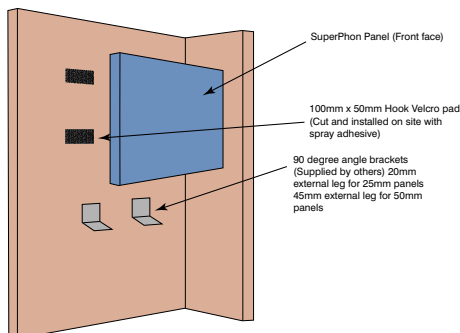

### Panel installed

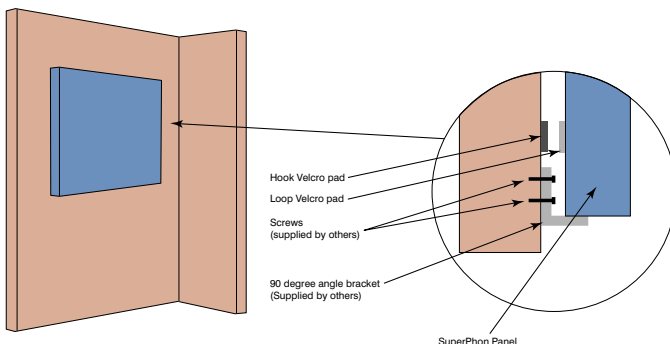

## SuperPhon STA-PUT Adhesive Fixings for Standard and High Impact Wall Panels

SuperPhon Panels are contact spray adhesive fixed to backing surface using SuperPhon STA-PUT spray can adhesive. This is a simple and strong adhesive system for bonding SuperPhon panels direct to walls and ceilings constructed of normal construction materials such as to concrete, brickwork, wood, plaster or metal. There is an immediate high strength bond, therefore no mechanical support is required or the need for drilling.



### SURFACE PREPARATION

The wall or ceiling must be clean, dry and free from loose paint or plaster, dust, oils, grease etc. Wallpaper should be removed fully, gloss paint roughened and emulsion paint brushed with a stiff brush to ensure it is firm. On absorbent surfaces an initial priming coat of SuperPhon STA-PUT spray adhesive may be necessary. Wall or ceiling surfaces must be flat and level.

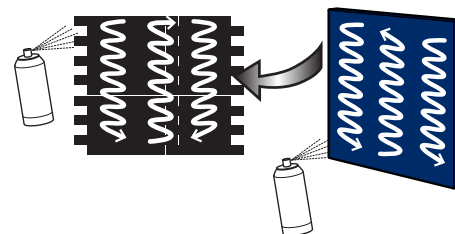

### FIXING PANELS

Mark the position of the panels on the wall. Spray the SuperPhon STA-PUT contact adhesive on the back of the panel and also on the designated wall area. Apply the adhesive vertically on the panels and horizontally on the wall area. 100% coverage required to both rear of panel and wall area. Allow the adhesive to dry for approximately 2 to 5 minutes at 23°C before bringing the two surfaces into close contact. Apply light even pressure using a clean pad or roller. For inverted panel applications and in high heat areas (30°C and above) we recommend additional mechanical fixings be added.

# SuperPhon® Installation continued

## Easy Fix System

Suitable for High Impact and standard wall panels.

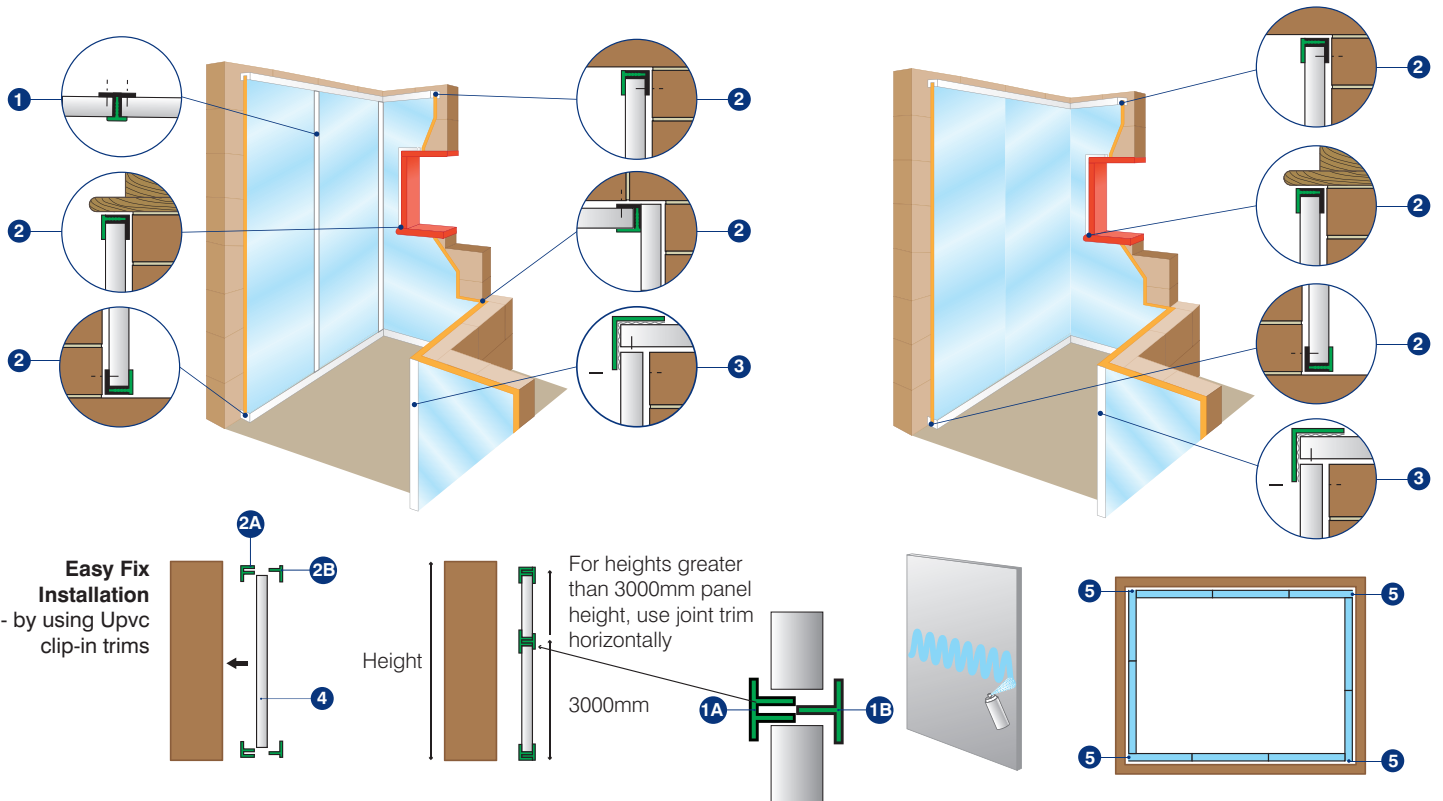

**Easy Fix Installation**  
- by using Upvc clip-in trims

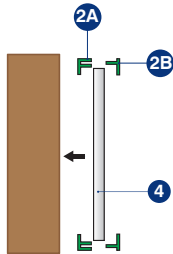

Height

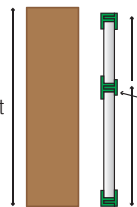

For heights greater than 3000mm panel height, use joint trim horizontally

3000mm

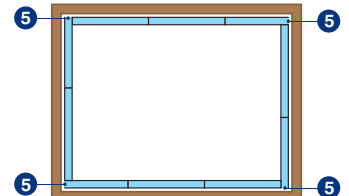
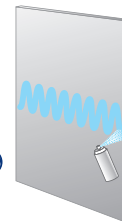
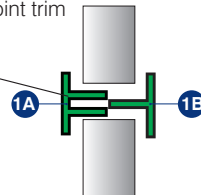

- |  |                       |
|--|-----------------------|
| 1. CMSJ 25 Joint Trim                  | 3. CMSA 25 Angle Trim |
| 2. CMSP 25 Perimeter Trim              | 4. SuperPhon Panel    |
| A = Female Section*                    | B = Male Section*     |
| *A and B sections supplied as one trim |                       |

- |                           |
|---------------------------|
| 2. CMSP 25 Perimeter Trim |
| 3. CMSA 25 Angle Trim     |
| 5. Cut Edge               |

## SuperPhon<sup>®</sup> Installation continued

### Fixing Baffles Direct from Ceiling

The channel is mechanically fixed directly into the soffit (appropriate fixings supplied by others) and the baffles inserted. A drill should then be pushed through the steel channel, the baffle and the other side of the steel channel. Insert the nylon bolt and apply the cap to the other end. Tighten the cap thus slightly compressing the steel channel to secure the panel.

- Often installers make up the channel Baffles on a work bench for ease of drilling and then separate the elements for actual installation.

### Installation of Baffles on Spiral Anchors

Standard baffle sizes should have two spiral anchors that should be inserted into the edge of the baffle allowing an equal distance from either edge of the baffle. Larger non standard baffles may require three or four fixing points. Contact CMS Danskin technical for advice.

Baffles will either be completely frameless or will have one edge where a frame is omitted to allow the spiral anchors to be wound in.

Wind the spiral anchor in so that the full extent of the spiral is embedded into the baffle thus the only part of the fixing exposed is the loop for attaching the ceiling suspension wire.

- Ceiling wire should be 2mm diameter standard suspended ceiling suspension wire allowing height adjustment and attached to the soffit with suitable fixings. Wire and soffit fixings supplied by others.
- Spiral anchors are available in two different sizes to fit the 25mm and 50mm baffle panels.

Holes to be drilled on site through channel and baffles. Ensure the holes are positioned to allow min 25mm distance from the top of the channel to the centre of the hole. Hole should be 8mm diameter to suit nylon fixing.

\* Fixing distances to be every 400mm.

0.7 gauge white steel channel  
27mm/52mm internal dimension top\*  
25mm/50mm internal dimension bottom\*

\* Steel channels are available in two different sizes to fit the 25mm and 50mm baffle panels.

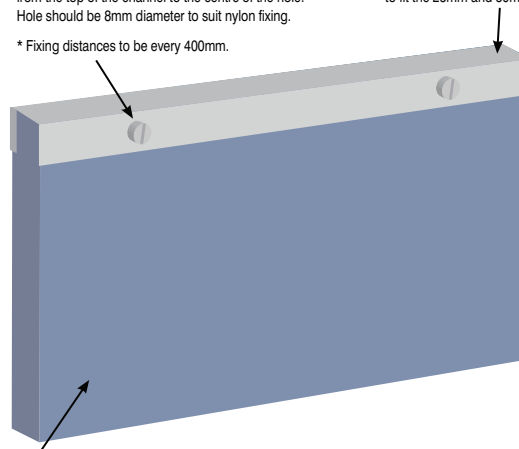

Baffles can be bespoke manufactured in 50mm or 25mm thickness. Typically installed with a 5mm gap between adjacent baffles.

*Diagrams shown are for illustrative purposes only.*

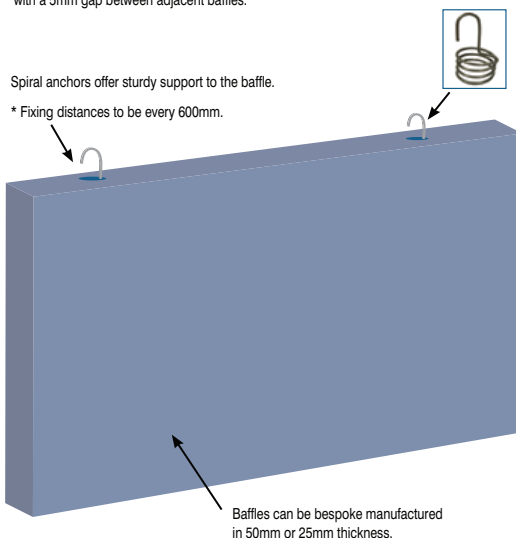

Spiral anchors offer sturdy support to the baffle.

\* Fixing distances to be every 600mm.

Baffles can be bespoke manufactured in 50mm or 25mm thickness.

# Fabrics

Our fabrics can be applied to almost all SuperPhon flat, shaped panels, are suitable for use with a number of different edge profiles and can be attractively tailored at the corners. Fabrics are bonded over the face and edges of the panel, and are returned to the reverse of the panel by a minimum of 25mm and bonded.

During installation, panels should only be handled whilst wearing clean, white, lightweight gloves. Please see separate recommendations for how to handle CMS Danskin's SuperPhon panels.

## Features and benefits

### Acoustic Transparency

Provided the fabric is unbacked, it allows sound to pass through it and into the absorptive material of the SuperPhon panel itself.

### Fire Resistance

Most of our fabrics are 'Class 1' for the Surface Spread of Flame in accordance with BS 476 Part 7, when tested as a composite with standard cores. Class 'O' Fabrics are also available upon request.

### Panel Tolerances

Standard panel tolerances (i.e. width and length +/-2mm).

### Bespoke Design

CMS Danskin's SuperPhon can support bespoke design requirements, such as corporate identity, commercial or decorative designs and murals. Designs can be worked across multiple, adjoined panels.

### Easy Maintenance

See our 'Treatment Guide' for a detailed breakdown of how to maintain and clean our fabric finishes.

## Testing

Only fabrics that have been tested with SuperPhon can be considered suitable. However, CMS Danskin can appraise previously untested fabrics for their suitability upon request. CMS Danskin test fabrics for the following characteristics:

- Acoustical transparency
- Dimensional stability
- Adhesion to core
- Adhesive wetting and bleeding
- Adhesive compatibility
- Telegraphing
- Elasticity
- Residual memory
- Core show-through

## Treatment guide

Blood	AC	Grass	C	Oil	BDC
Chewing Gum	IBDC	Grease	BDC	Paint - water based	AFC
Chocolate	BDC	Ink - Ballpoint	DE	Paint - oil based	AHDC
Cooking Oils	BDC	Ink - Fountain	AC	Sauces	BCD
Crayon/Colour Markers	BDC	Lipstick	BECD	Shoe Polish	BCD
Drinks (Cola, Juices, Beer)	AC	Mildew	C	Urine	AC
Dust/Dirt	Vacuum, then J or C	Milk	AE	Vomit	ACD
Excrement	BC	Mud	BC	Wine	A, add salt, C
		Nail Polish	AG		

**A** Mop up excess as soon as possible.

**B** Remove surplus with a knife edge or appropriate instrument.

**C** Sponge with a solution of carpet shampoo working from well outside the stain in a circular motion towards the centre [this avoids spreading the stain]. Sponge afterwards with clean warm water and mop up excess moisture with a clean dry cloth or sponge.

Allow to dry then brush gently with a soft cloth. If any stain remains, sponge with a solution of 1 part household bleach to 6 parts water. Rinse thoroughly after treatment.

**D** Lightly sponge with household dry cleaning fluid and blot. Apply sparingly, as the substance may have an adverse effect on the adhesive.

**E** Sponge with methylated spirits and blot dry.

**F** Lubricate stain with glycerine or petroleum jelly.

**G** Apply nail polish remover. The nail polish remover should not include lanolin or be of a greasy nature.

**H** Sponge with turpentine or a substitute.

**I** Freeze with ice cubes and scrape away when cold.

**J** Clean with regular extractive carpet cleaner if possible.

## Frequently asked questions

### What is acoustical transparency?

By adding fabric, particularly with a backing, to an acoustic panel, it is possible to reduce its ability to absorb sound waves. A fabric with good acoustical transparency allows sound to pass through and into the panel core. As a rule, if air can pass through the fabric without difficulty, it is likely to have good acoustical transparency.

### What are pull lines?

Even when a fabric is flat, certain types of lighting reflecting from different tensioned fibres can create the impression of unevenness at the edges of bond applied fabrics. This can manifest itself as wavelike lines across the panel which appear and disappear depending upon the angle from which the panel is viewed and the lighting conditions. Research into this phenomenon is still on-going, with no conclusions having yet been reached. However, crepe-type weaves and fabrics containing extruded and unspun fibres appear to be vulnerable to pull lines, and the phenomenon is more apparent with black and grey/blue fabrics.

### What is blooming?

Saline-based fire retardant treatments can become soluble when exposed to a Relative Humidity of 80% or more. When the Relative Humidity subsequently reduces to 60% or less (normal levels, in other words), the retardant treatment is drawn to the surface, where it evaporates, leaving behind a 'bloom' of white residue. This residue can discolour the fabric and is quite difficult to treat. This is a rare occurrence with the standard range of CMS Danskin SuperPhon fabrics, which have been selected for their stability.

### Which fabrics offer dimensional stability?

According to SuperPhon test data, the most dimensionally stable fabrics use the following fibres: polypropylene, olefin, polyolefin, modacrylic and polyester. Although we will test any fabric for dimensional stability, it is worth noting that fabrics containing certain fibres are more prone to instability, particularly silk, nylon and rayon. It is worth noting that the application of a latex or acrylic backing will not stabilise a fabric which is considered dimensionally unstable.

### Does piercing fabrics improve acoustic performance?

No, as most fabrics tend to 'heal' over a relatively short period of time anyway. This practice was formerly employed to prevent the occurrence of mildew.



**CMS Danskin Central/Southern Office**

Unit 2 Lyncastle Road, Appleton, Warrington WA4 4SN

Tel: 01925 577711 Fax: 01925 577733

**CMS Danskin Scotland Office**

1 Netherton Road, Wishaw, North Lanarkshire ML2 0EQ

Tel: 01698 356000 Fax: 01698 372222



© CMS Danskin Acoustics

The information provided here is, to the best of our knowledge, accurate at the time of going to press. However, due to CMS Danskin's commitment to a policy of continuous development, we reserve the right to make changes when necessary and without prior notification. We can't accept responsibility for products that are not installed or used in accordance with our specifications and instructions. For the most up-to-date information and data, see our website: [www.cmsdanskin.co.uk](http://www.cmsdanskin.co.uk).

MH 10/2013 Issue 1