

Dulok-25™

Double wire security panel system



Experience the Difference...

System details

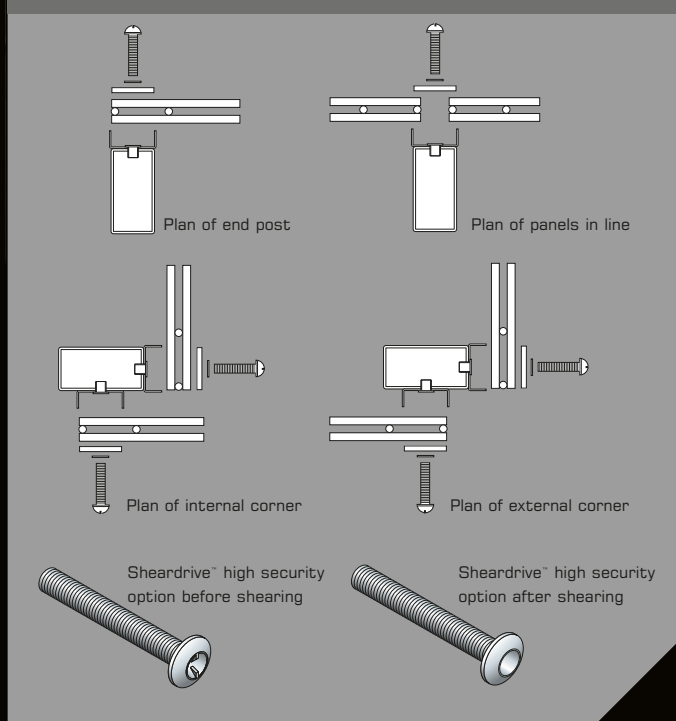

Dulok-25 posts and clamps

For the Dulok-25 double wire panel system, CLD has developed a post and clamp bar system which provides a simple method of securing. Complete with an anti-vandal fastener and installed with either a battery-powered driver or traditional tools, this system offers a rapid and secure installation.

Description

The posts are supplied complete with a full-length flat clamp bar and M8 x 40 mm pin hex dome-head security screws, or Sheardrive™ bolts.

Finish

All posts and clamps are supplied galvanised only or galvanised and polyester powder-coated in colours to match the fencing panels.

Dimensions

Posts:	60 x 40 x 2.5 mm RHS (up to 2.43 m high)
	80 x 40 x 3 mm RHS (up to 3.66 m high)
	100 x 50 x 3 mm RHS (up to 4.46 m high)
	120 x 60 x 3.5 mm RHS (up to 6.09 m high)
Flat clamp bars:	40 x 5 mm
Post centres:	2520 mm

Sloping ground

Panels can be stepped as required within the clamp bar system. Where gradients exceed 1:16, it is recommended that taller panels are either part-buried or additional posts are used.

Variations

The posts are available in a range of lengths to accommodate panel heights and ground conditions. In addition, many variations are available:

- wall fixing plates, cranked posts or base plated
- cranked or straight extensions for barbed or razor wire
- cranked panels



Find out more

Scan this QR code with your smart device to instantly access our website and find out what CLD can do for you.

All information contained within this document including technical details, graphics and photographs are copyright © CLD Fencing Systems 2013. This document may not be reproduced, copied, transmitted or stored in any form without written permission from CLD Fencing Systems.

All information correct at time of printing. We reserve the right to alter specification without notice.

Head office:

Unit 11, Springvale Business Centre, Millbuck Way, Sandbach, Cheshire, CW11 3HY

T +44(0)1270764751 F +44(0)1270757503

E-mail sales@cld-fencing.com

www.cld-fencing.com

Dulok-25™ Double wire security panel system

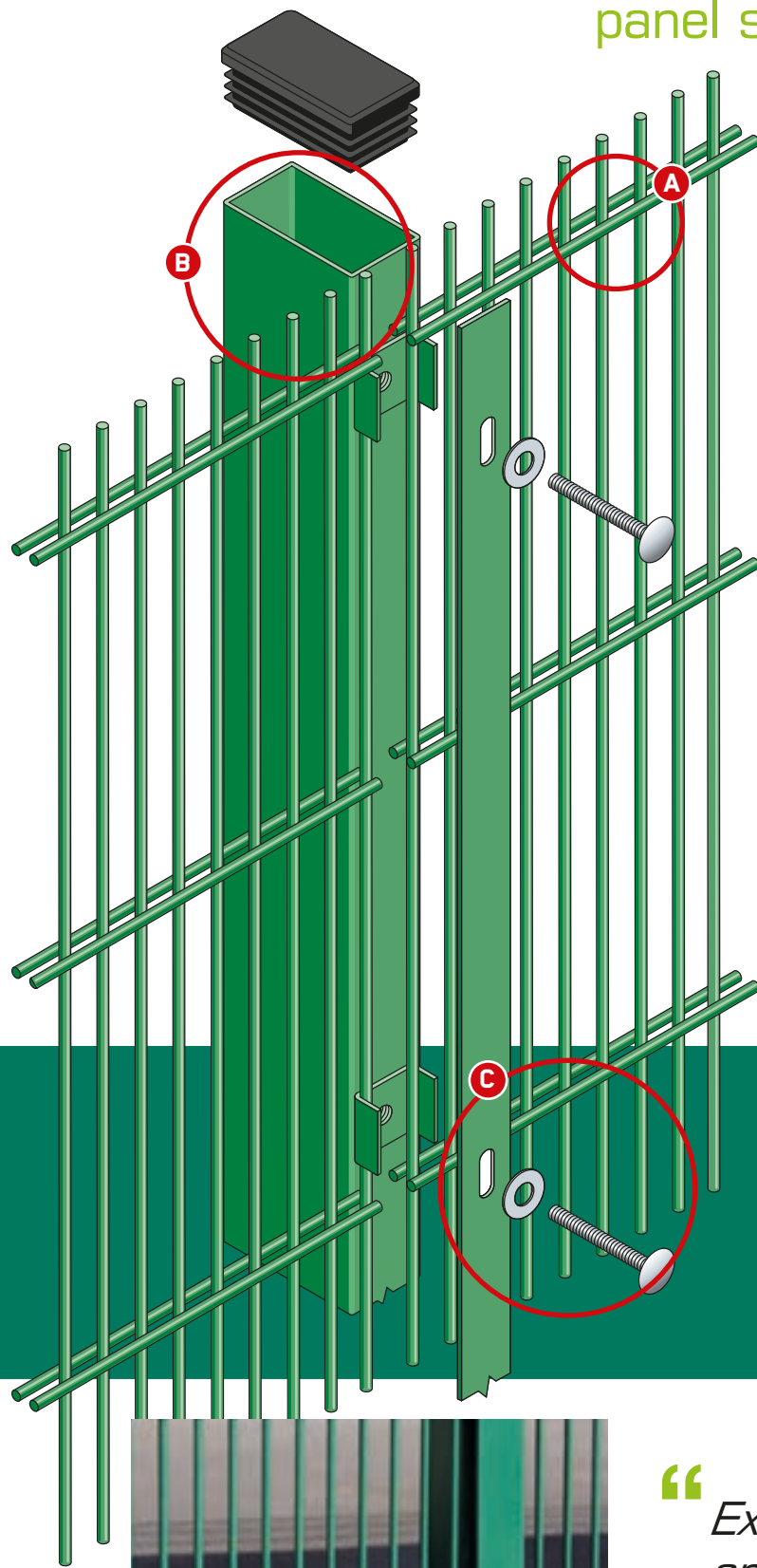

Exploded view of post and clamp for Dulok-25 double wire panel system



Sheardrive™ option

A Twin horizontal wires for anti-cut through properties and high rigidity

B Galvanised and polyester powder coated RHS post

C Secure pin hex bolt for quick installation

Conforms to **BS1722: Part 14**

Features:

- Anti-cut double wire panels
- Anti-climb
- Wide range of height options (up to 6 m high)
- Full range of RAL colours available

Suitable for:

- Industrial and commercial buildings
- Public buildings
- MOD sites
- Police stations and secure units



Description

The Dulok-25 Double Wire panel system can be used in applications such as data centres, secure units, MOD sites and police stations. With its twin 8 mm wire configuration and 25 mm spaced 6 mm vertical wires making this one of the strongest fence systems on the market.

Panel dimensions

Heights†	1830, 2030, 2430, 3060, 4060, 4460, 5090, 5490, 6090 mm
Panel width	2506 mm
Mesh sizes	200 x 25 mm
Wire diameter	6 mm verticals 2 x 8 mm horizontals
Top edge projection	30mm†

† Fence heights above 2.43 m are made up of 2 or more panels.
‡ Can be inverted to give flush edge.



Find out more
Scan this QR code with your smart device to instantly access even more information.

Finish

Hot dip galvanised only or galvanised and polyester powder-coated. The full range of RAL colours are available.

Specification clauses

To be read with Preliminaries/General conditions.

Open mesh steel panel general purpose fencing/gates

- Manufacturer & Ref: CLD Fencing Systems www.cld-fencing.com, Tel. 01270 764751, CLD Dulok-25 Double Wire Panel System.
- Height:* Nominal height:* Mesh & wire: 200 x 25 mm mesh; two 8 mm horizontal wires, one 6 mm vertical wire, galvanised and polyester powder-coated to a minimum of 60 microns.
- Posts: x x** mm RHS, galvanised after manufacture and polyester powder-coated with 40 x 5 mm flat clamp bars galvanised and polyester powdercoated to match post.
- Fixings: M8 x 40 mm pin hex dome-head security screws.
- Maximum post centres: 2.52 m.
- Set posts: Set posts in holes 300 mm diameter x 750 mm*** deep, filled not less than half the depth with concrete.
- Bottom of fencing to be approx. 50 mm above final ground level.
- Other requirements: PPC Colour Green RAL 6005 or galvanised only.
- Sheardrive™ fixing if required instead of pin hex.

** See specification for available heights.
** See back page for post specifications.
*** Depending on fence height.



“Extremely robust and very hard to climb...”



FenceCAD
CAD Drawings for Security Fences & Gate Systems

Drawn by Architects for Architects

Visit www.cld-fencing.com/login.php

