

SWELLTITE®

COMPOSITE BENTONITE WATERPROOFING SYSTEM

DESCRIPTION

SWELLTITE is a highly effective waterproofing composite of sodium bentonite compound integrally bonded to a geomembrane liner. This composition combines the active waterproofing benefits of sodium bentonite with the strength and puncture resistance of a thick geomembrane liner.

SWELLTITE is a true advancement in waterproofing membrane technology. Unlike other membrane systems, SWELLTITE's reactive bentonite compound can expand to seal small punctures in the membrane. SWELLTITE is manufactured at a factory controlled thickness of 2 mm assuring the specifier, contractor, and owner of consistent material application. This engineered composite consists of a thick geomembrane liner and bentonite compound with a water soluble film attached. SWELLTITE contains virtually zero VOC, can be installed to green concrete, and most importantly, has proven effective for more than 20 years.

APPLICATIONS

SWELLTITE is designed for below-ground vertical and horizontal structural foundation surfaces, as well as, above ground split-slab construction. Typical below-ground applications include backfilled concrete walls, masonry block walls, earth-covered roofs, and tunnel roofs. Typical above ground split-slab construction applications include plaza decks, parking decks, and balconies. Additionally, SWELLTITE can be used for interior split-slab applications for mechanical rooms, kitchens, and laboratory facilities. Applications may include structures under continuous or intermittent hydrostatic pressure.

INSTALLATION

General: Install SWELLTITE and accessory products in strict accordance with the manufacturer's installation guidelines. Install SWELLTITE with the bentonite compound directly against the substrate to be waterproofed. Schedule waterproofing material installation to permit prompt placement of backfill material or concrete. For applications not covered herein, contact CETCO for specific installation guidelines.

Storage: Store SWELLTITE and accessory products in a dry location protected from construction operations and weather. Protect materials from moisture, excessive temperatures and prolonged exposure to direct sunlight during storage. When storing materials outside at a jobsite, provide weatherproof covering, top and all sides (allow for adequate ventilation). Do not double stack pallets in storage or during shipment.

Preparatory Work: Structural concrete surfaces should be smooth and free of dirt, rock, debris, oil, grease, laitance, or other foreign materials. Remove form fins and other protrusions to match substrate surface. Completely fill any Form-tie holes, honeycombing, voids, and cracks with non-shrink cementitious grout, VOLSEAL 600TG or BENTOSEAL. Concrete surfaces to receive VOLSEAL 600TG should be water cured a minimum of 7 days prior to application. Where possible, design horizontal concrete surfaces with proper slope to drain.

FOUNDATION WALL INSTALLATION

Before installing SWELLTITE membrane to foundation walls, prepare substrate, and detail all vertical inside corners, penetrations, and the footing/wall joint as follows:

Vertical Inside Corners: Install a 19 mm thick, continuous fillet of BENTOSEAL or VOLSEAL 600TG Mastic at all vertical inside corners.

Penetrations: Apply a 19 mm thick fillet of BENTOSEAL or VOLSEAL 600TG Mastic around base of penetrations. Extend mastic a minimum of 150 mm outward from penetration 2.3 mm thick. After SWELLTITE membrane is installed, apply a counter flashing of mastic at membrane edge around penetration.

Footing/Wall Joint: Install at footing/wall joint a continuous 19 mm thick, 45° angle fillet of BENTOSEAL or VOLSEAL 600TG.

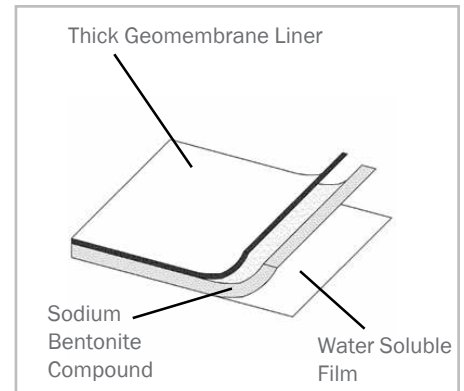

SWELLTITE composite

SWELLTITE®

COMPOSITE BENTONITE WATERPROOFING SYSTEM

Membrane Installation: Starting at the base of the wall, install the membrane over the BENTOSEAL/VOLSEAL 600TG fillet and onto the footing a minimum of 150 mm with bentonite compound directly against the wall (thick liner side toward installer). Secure all membrane edges with washer-head mechanical fasteners maximum 600 mm on centre or less as required to contour surface. SWELLTITE membrane may be installed either horizontally or vertically oriented. Overlap all membrane edges a minimum of 50 mm. Stagger membrane roll ends a minimum of 300 mm. Seal all membrane overlap seams with CETCO SEAMTAPE. Continue membrane installation to finished ground detail or as specified.

Cut membrane to closely fit around penetrations. Trowel a minimum 19 mm thick layer of BENTOSEAL or VOLSEAL 600TG Mastic around penetrations. Extend mastic onto penetration and completely fill area between membrane edge and penetration. Seal all overlap seams with CETCO SEAMTAPE.

Terminate SWELLTITE membrane 300 mm below finished ground elevation with washer-head fasteners maximum 300 mm on centre. Install CETbit 300 flashing to primed concrete substrate with bottom edge overlapping top edge of SWELLTITE membrane minimum 100 mm. Overlap all roll ends a minimum 100 mm to form a continuous flashing. Height of flashing shall be per project details and specifications. Install a rigid termination bar along top edge of CETbit 300 flashing; fastened maximum 300 mm on centre. Complete ground termination detail with tooled bead of CETSEAL along the top edge, at all penetrations through the flashing and all exposed overlap seams.

Backfill material should be placed and compacted to 85% Modified Proctor density immediately following the application of the membrane. If backfill cannot be applied immediately, protect membrane edges from

precipitation with CETCO SEAMTAPE. If backfill contains sharp or irregular material, cover membrane with CETCO approved protection material course to avoid damage during backfilling and compaction.

Tie into underslab waterproofing as required by overlapping the underslab waterproofing a minimum of 150 mm. When a drain tile is required, install it below the top of the footing.

Masonry Block Walls: CETCO recommends that the masonry block cells be filled with cementitious grout or concrete. All mortar joints should be completely filled and struck flush before membrane is installed to masonry walls.

HORIZONTAL DECK INSTALLATION

Before installing SWELLTITE membrane, prepare substrate and detail all drains, transition corners and penetrations. Consult manufacturer if deck is precast concrete planks or for other conditions not stated herein.

Drains: Trowel a minimum 2.3 mm thick layer of VOLSEAL 600TG on the drain ring and continuing into the drains inward throat slope. Extend VOLSEAL 600TG a minimum of 150 mm around the drain. Allow VOLSEAL 600TG to cure a minimum of 12 hours prior to installing membrane. After SWELLTITE membrane is installed around drain, apply a 1.5 mm thick counter flashing of VOLSEAL 600TG covering the membrane edge.

Penetrations: Trowel a minimum 19 mm fillet of VOLSEAL 600TG around the penetration. Extend VOLSEAL 600TG outward from penetration a minimum of 150 mm at 2.3 mm thick. After membrane has been installed overlapping VOLSEAL 600TG 50 mm, apply a 1.5 mm thick counter flashing of VOLSEAL 600TG at the membrane edge.

Transition Corners: Apply a 19 mm thick VOLSEAL 600TG fillet to inside transition corners. Then extend VOLSEAL 600TG at 2.3 mm minimum thickness for 150 mm in both directions from the corner. Allow VOLSEAL 600TG to cure a minimum of 12 hours prior to installing membrane. After membrane has been installed to the corner, apply a 1.5 mm thick counter flashing of VOLSEAL 600TG covering the membrane edge.

Membrane Installation: Install membrane with bentonite compound directly against the deck (thick liner side up) from the low point to the high point across the fall line to create a shingle-style installation. Overlap all membrane edges a minimum of 50 mm. Stagger membrane roll ends a minimum 300 mm. Seal all membrane overlap seams with CETCO SEAMTAPE.

Cut membrane to closely fit around penetrations overlapping previously installed VOLSEAL 600TG. Apply 1.5 mm thick counter flashing of VOLSEAL 600TG over membrane edge.

OPTIONAL ADHESIVE METHOD

Apply MAXBIT SKW by brush or trowel at a rate of 1.2 kg/sqm and allow to cure for between 30 and 60 minutes (depending upon ambient temperatures) before applying SWELLTITE membrane. After adhesive has cured, follow membrane installation instructions for applicable application, foundation wall or deck, excluding the mechanical fasteners. Primed surfaces not covered with membrane during the same working day must be re-coated with MAXBIT SKW.

SWELLTITE® COMPOSITE BENTONITE WATERPROOFING SYSTEM

SIZE PACKAGING

SWELLTITE roll size is 1.02 m x 10.0 m; 10.2 sqm per roll. Each roll weighs approximately 31.4 kg.

LIMITATIONS

Do not install SWELLTITE in standing water or during precipitation. If ground water contains strong acids, alkalis, or is of a conductivity of 2500 µmhos or greater, submit water samples to the manufacturer for compatibility testing.

SWELLTITE is not designed for unconfined above-ground waterproofing applications or subsurface applications that do not provide full confinement coverage. Do not install SWELLTITE on horizontal plaza deck applications that utilize pavers placed on pedestals.

SWELLTITE is not designed to waterproof expansion joints. Expansion joints require a properly engineered expansion joint product manufactured. For foundation walls, backfill should consist of compactible soils or crushed stone (19 mm or less). Compact soils to minimum 85% Modified Proctor den-

sity. Stone backfill larger than 19 mm will require the use of a protection course; consult CETCO for specific guidelines. Avoid backfill with aggregate 38 mm or larger.

On horizontal decks, SWELLTITE requires proper containment from a topping ballast material; a minimum 75 mm thick structural concrete slab or a minimum paver assembly weight of 97 kg per square metre (includes sand or grout leveling course). When compactible soil topping is used, it must be at least 450 mm thick and compacted to a minimum 85% Modified Proctor density.

ACCESSORY PRODUCTS

VOLSEAL 600TG LIQUID FLASHING: VOLSEAL 600TG is a trowel-grade waterproofing mastic used as a detailing product around penetrations, drains, and at corner transitions for horizontal deck and vertical wall installations.

BENTOSEAL®: trowel ground sodium bentonite mastic used for detailing mastic around penetrations and corner transitions for vertical wall SWELLTITE installations.

MAXBIT SKW: Cold-applied modified bitumen-rubber compound applied to substrates to promote the adhesion of SWELLTITE membrane; typical coverage rate is 1.2 kg /sqm.

SEAMTAPE®: tape used to seal membrane overlap seams.

AQUADRAIN®: prefabricated drainage composite consisting of a heavy filter fabric adhered to a high-strength plastic drainage core.

WATERSTOP-RX®: expanding bentonite based concrete joint strip waterstop designed to replace PVC waterstops. Adhered into place with CETSEAL.

CETbit 300: Self-adhesive flashing membrane for ground level terminations.

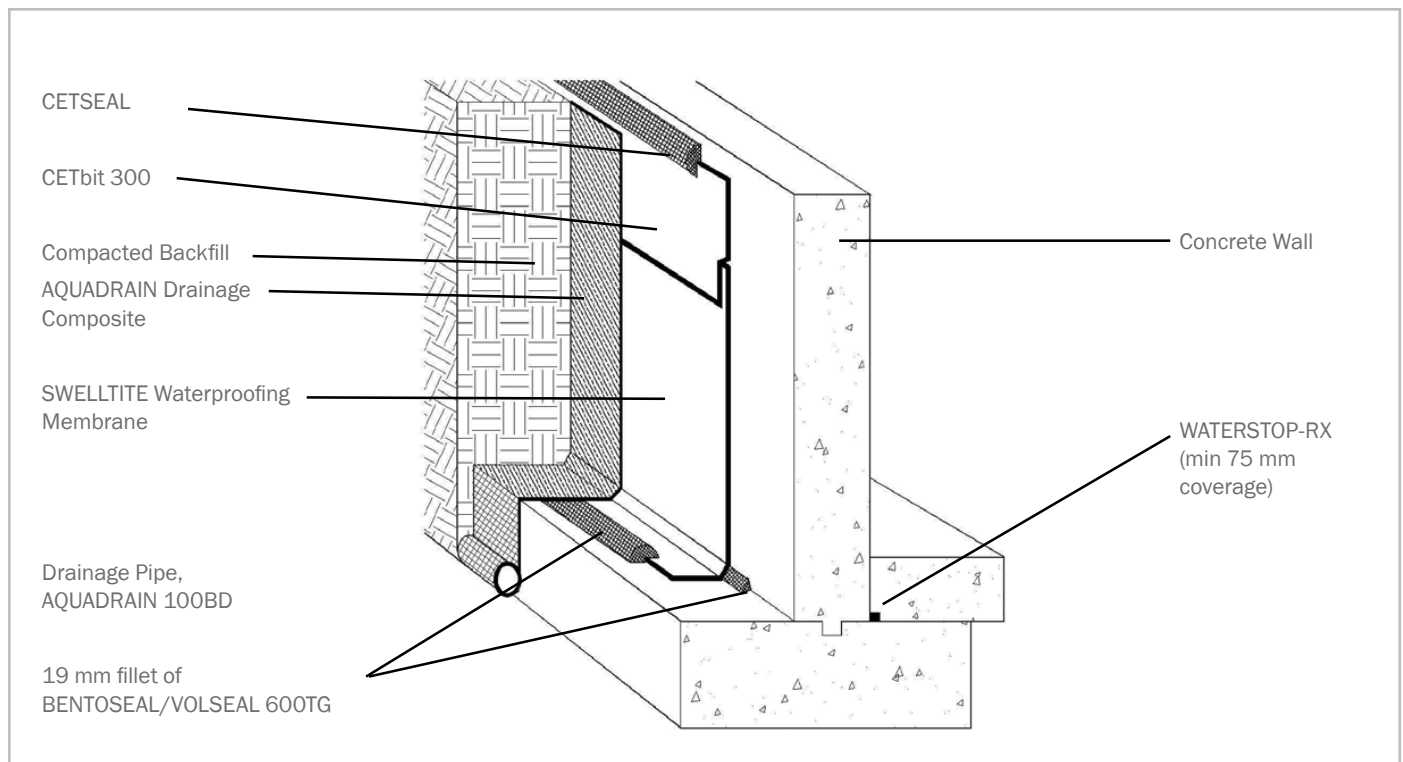

SWELLTITE®

COMPOSITE BENTONITE WATERPROOFING SYSTEM

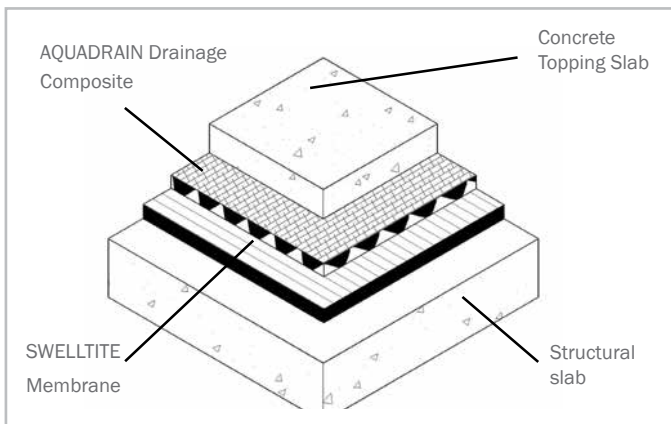

General application details

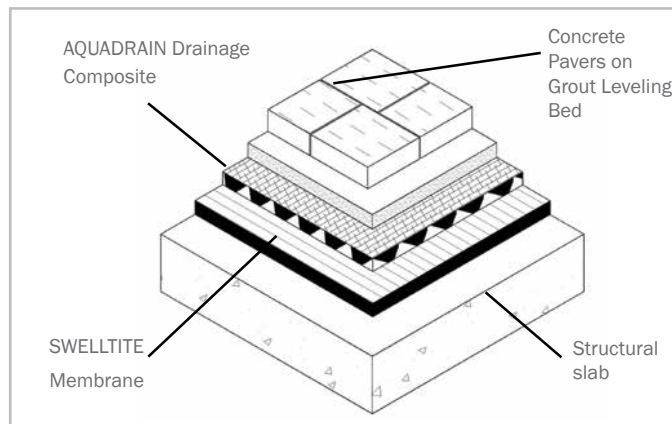

Plaza deck – pavers over grout bed

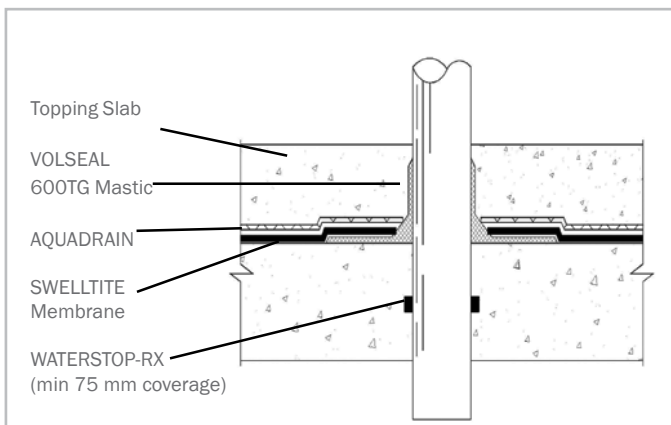

Plaza deck penetration detail

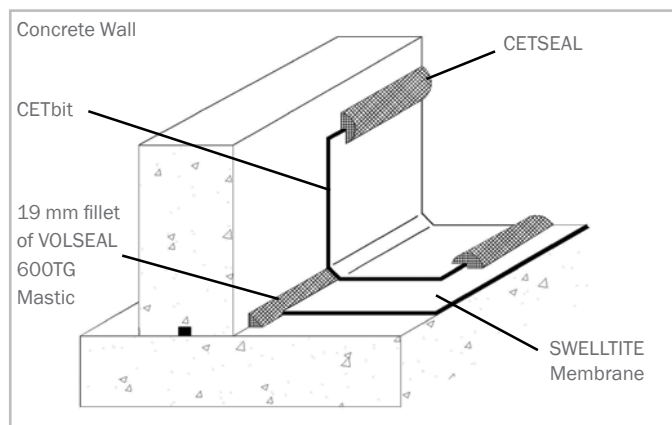

Plaza deck transition detail

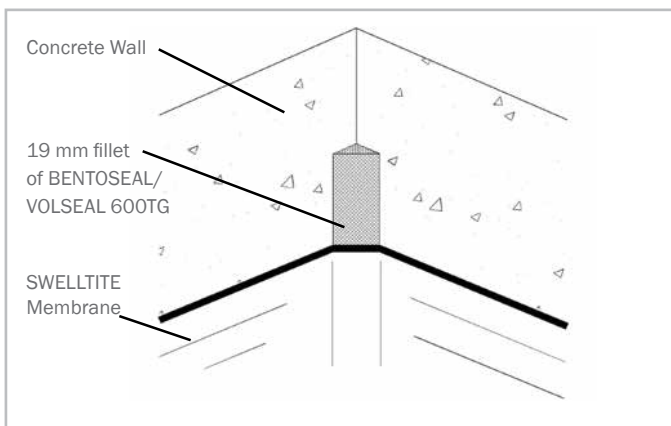

Inside corner wall detail

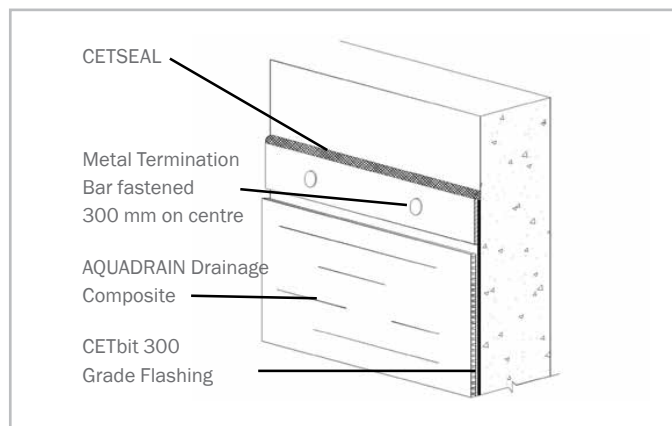

Typical ground termination



1488-CPD-0163/Z

EN 13491:2004 + EN 13491:2004/A1:2006

UK | Birkenhead Road, Wallasey, CH44 7BU | +44 151 606 5900
 PL | Korpele 13A – Strefa, 12-100 Szczytno | +48 89 624 7300
 ES | CV-50 KM74.5, 46380 Cheste (Valencia) | +34 902 820 200
 ☒ | contact@cetco.com

www.CETCO.com



OUR STANDARDS. YOUR PEACE OF MIND.

A Minerals Technologies Company

UPDATED: SEPTEMBER 2013

IMPORTANT: The information contained herein supersedes all previous printed versions, and is believed to be accurate and reliable. For the most up-to-date information, please contact CETCO sales team. CETCO accepts no responsibility for the results obtained through application of this product. CETCO reserves the right to update information without notice.

FORM: TDS_SWELLTITE_EMEA_EN_201311_V1