

CEMBRIT

Cembrit Construction

Installation

Table of Contents

Product Information	2	Rivets on aluminium	13
Dimensions	3	Screws and rivets on steel	
Accessories	4	sub-construction	20
Sub-constructions and Supports	5	Weatherboards	27
Screws on wooden sub-constructions	6	Care & Maintenance	30
		Health and Safety	32
		Warranty and disclaimer	33



Product Information



Product Information

Cembrit fibre cement is a modern building material made from natural and environmentally friendly raw materials. Holding more than 80 years of experience within the manufacture of fibre cement, Cembrit ensures a sustainable product which has accumulated all the advantages of fibre cement.

Quality:

Cembrit product specifications and classifications comply with EN 12467:2012 and 13501-1:2002.

Cembrit Construction:

- is manufactured in accordance with the quality management system ISO 9001:2008 and the environmental management system ISO 14001:2004 as well as OHSAS 18001:2007
- complies with the provisions set out in the Construction Products Regulation (EU) No. 305/2011
- holds an Environmental Product Declaration EPD-CEM-2012111-E according to ISO 14025
- complies with the CE Declaration of Performance

Cembrit Construction is an untreated fibre-cement board that allows the authentic appearance of the rough fibre cement to stand out. In nature, Cembrit Construction is a building board which can be installed in all self-ventilated light weight facade constructions.

Featuring properties such as non combustibility, sound and weather insulation as well as high impact strength, Cembrit Construction is the ideal cladding product.

The fibre-cement boards are produced from a composition of Portland cement, mineral fillers, cellulose and plastic fibres.



Dimensions

Dimensions	Thickness	Width mm	Length mm
Size	6 mm	1200 1250	2500
Size	8 mm	1192 1200 1250	2500/3050 2500/3050 2500
Size	10 mm	1192 1200	3050

Standard sizes

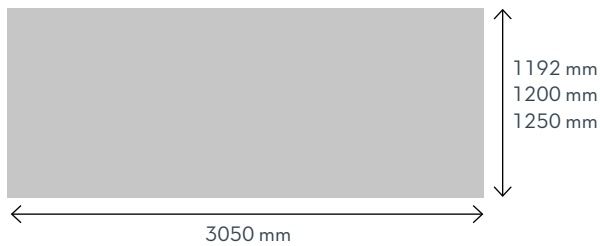

Project sales



Surface appearance

Cembrit Construction is an untreated, grey fibre-cement board with a smooth surface and strong properties. Because of its natural composition, variations in appearance may occur in the individual boards and from board to board. Please note that this does not have any negative effect upon the durability and performance of the boards.

In order to minimise differences in the end-result, we recommended that boards intended for the same facade are taken from the same batch as minor variations may occur from one production lot to another.

Cembrit Construction can be painted on-site with acrylic paint systems suitable for cement based materials.

Preferred application areas are:

- Self-ventilating facades
- Dormer window
- Weatherboards
- Window elements
- Eaves and roof edges
- Balconies
- Prefabricated facade elements

Accessories

Cembrit screws for fixing facade boards are made of stainless steel for achieving the highest corrosion resistance. Mushroom head wood screws 4.5 x 36/41 are used for wooden sub-constructions. The screws have a sharp point and a fast cutting thread which ensure firm fixing with a high pull-out value.

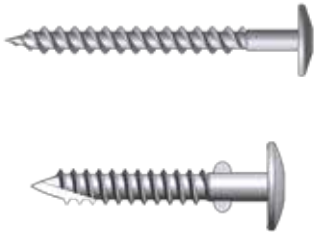

An alternative solution for wooden sub-constructions is the wing screw 4.9 x 38 which is equipped with a drill bit and therefore requires no pre-drilling.



For steel sub-constructions with profiles ≥ 0.5 use Cembrit stainless steel self drilling and thread cutting screw 4.8 x 29 #1 with drilling capacity 0.5-1.5 mm. As an alternative use Cembrit stainless steel rivets 4.8x20.



All screws for Cembrit Construction are delivered plain and with a screw bit included ready to use.



On aluminium sub-constructions rivets are most commonly used. Cembrit rivets 4.0 x 20 feature an aluminium body with a stainless steel mandrel. At fix-points, a sleeve is used to prevent movement of the board.



In order to allow the boards to move freely in sliding points when influenced by moisture and temperature changes, a stand-off head must be used ensuring a small space between the board and the rivet head. At fix points, a fixing ring is used.



For securing the above mentioned free movement of the boards, it is of great importance that the drill hole in the aluminium sub-construction and the drill hole in the Cembrit board are concentric. This is ensured by using an assisting tool:



4.1 mm HSS drill for rivets in aluminium profiles (4.0 x 20).
4.9 mm HSS drill for rivets in steel profiles (4.8 x 20).



Special drill bit such as TCT Drill (7-8-9 mm) from Irwin Tools for pre-drilling in the facade boards.

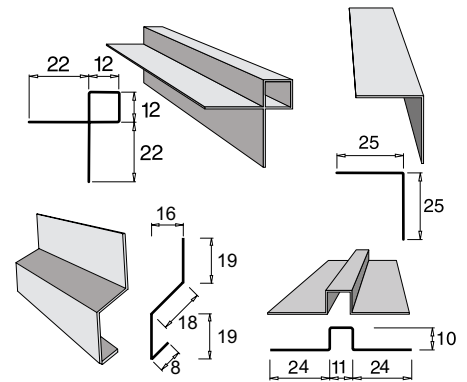

Aluminium corner profiles for internal and external corners are available on request.



Cembrit EPDM rubber underlay should always be placed under the Cembrit boards using mechanical fixing.

Cembrit boards can be fixed by gluing them to a sub-structure of planed impregnated wood or aluminium.

Note! The glue supplier's recommendations must be followed in this type of installation. For further information, please contact your local Cembrit representative.

Sub-constructions and Supports

Basic sub-constructions

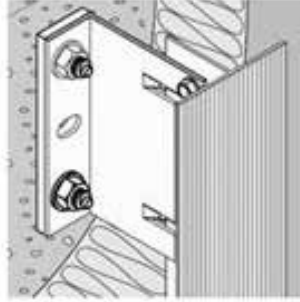
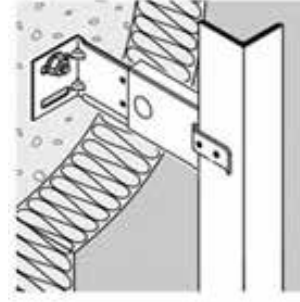
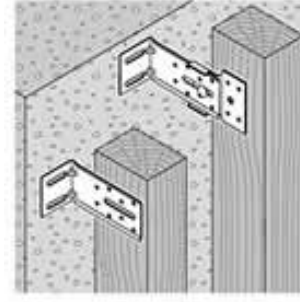
Wooden sub-construction	Metal sub-construction		Combined sub-construction
	Aluminium sub-construction	Steel sub-construction	
			

Important! Cladding with Cembrit products must always be carried out as a ventilated facade with min 20 mm distance between the cladding and the rear lining (insulation material). However, in special situations (e.g. high rise buildings), local regulations may demand a larger ventilation gap. Inlet and outlet openings must have a cross section of least 100 cm²/m.

Screws on wooden sub-constructions

Fixing Details

Vertical board orientation

Installation on wood, vertical sub-construction
 Max dimensions 8 x 1250 x 2500/3050 mm
 Drill hole in the boards: Ø8

Wind load	Max support distance	Max fixing distance	Edge distance	Corner distance
kN/m ²	k mm	h, g mm	a mm	c mm
0.60	630	600	25-150	100-150*
0.70	630	600		
0.80	630	600		
0.90	630	500		
1.00	630	400		
1.10	630	400		
1.20	630	400		
1.30	420	500		
1.40	420	500		
1.50	420	450		
1.60	420	400		
1.70	420	400		
1.80	420	350		
1.90	420	350		
2.00	420	350		

*Overhang e.g. windows max 200 mm

Horizontal board orientation

Installation on wood, vertical sub-construction
 Max dimensions 8 x 1250 x 2500/3050 mm
 Drill hole in the boards: Ø8

Wind load	Max support distance	Max fixing distance	Edge distance	Corner distance
kN/m ²	k mm	h, g mm	a mm	c mm
0.60	630	600	25-150	100-150*
0.70	630	600		
0.80	630	600		
0.90	630	500		
1.00	500	500		
1.10	500	500		
1.20	500	400		
1.30	500	400		
1.40	500	400		
1.50	440	400		
1.60	440	400		
1.70	440	350		
1.80	420	350		
1.90	420	350		
2.00	420	350		

*Overhang e.g. windows max 200 mm

Front view

vertical orientation

The installer is responsible for establishing a plane and strong sub-construction able to obtain the loads appearing on the actual facade and observing the fixing distances described in this manual.

Front view

horizontal orientation

Facade boards are normally installed in a vertical position on a vertical sub-structure. It is however possible to install the boards in a horizontal position. The guidelines for fixing are identical, which means the edge distances, corner distances etc. follow the sub-structure.

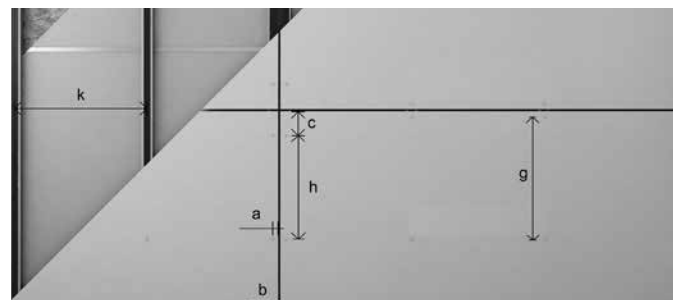
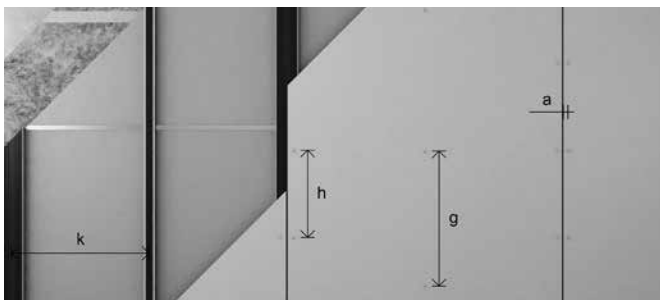

Screws on wooden sub-constructions

Fixing details screws on wood

Horizontal cross section vertical joint

- 31 Load bearing wall
- 2 Insulation
- 4 Wind break
- 5 Air gap min 20 mm
- 6 Batten min 20 x 100 mm
- 8 EPDM underlay
- 9 Facade screw 4.5 x 36/41
- 21 Facade board
- a Edge distance 25-150 mm
- b Joint width 8 mm

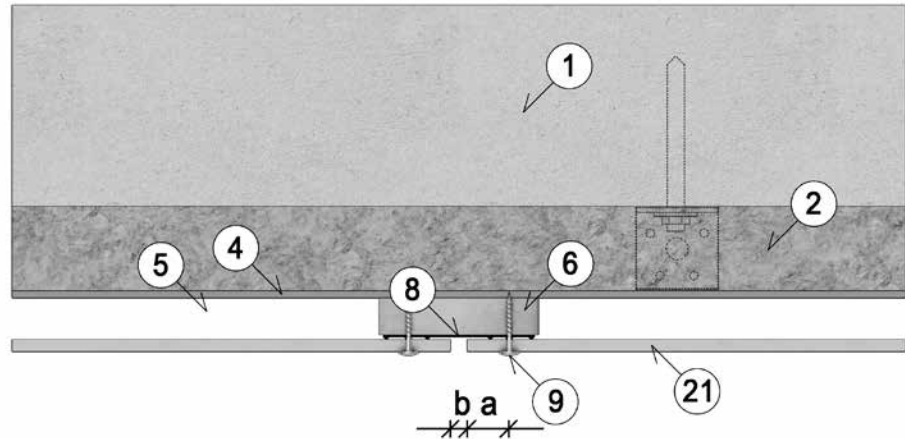

Horizontal cross section intermediate support

- 31 Load bearing wall
- 2 Insulation
- 4 Wind break
- 5 Air gap min 20 mm
- 6 Batten min 20 x 45 mm
- 7 EPDM underlay
- 9 Facade screw 4.5 x 36/41
- 21 Facade board

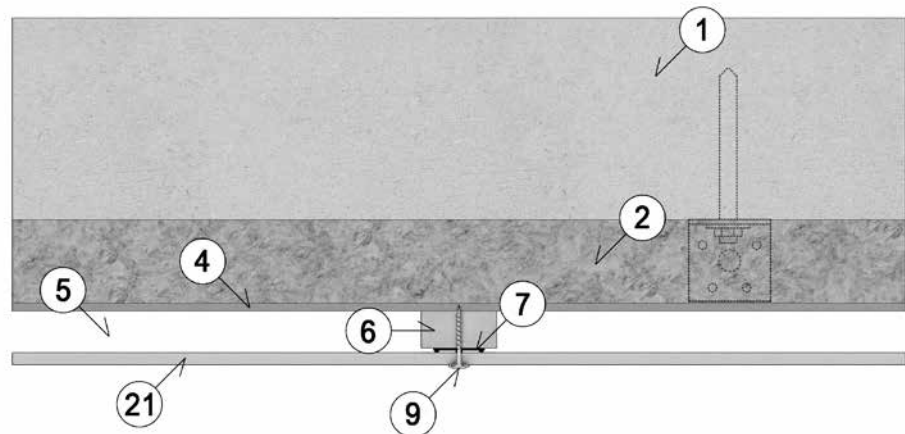

Screws on wooden sub-constructions

Horizontal cross section external corner

- 31 Load bearing wall
- 2 Insulation
- 4 Wind break
- 5 Air gap min 20 mm
- 6 Batten min 20 x 100 mm
- 8 EPDM underlay
- 9 Facade screw 4.5 x 36/41
- 21 Facade board
- a Edge distance 25-150 mm
- b Joint width 8 mm

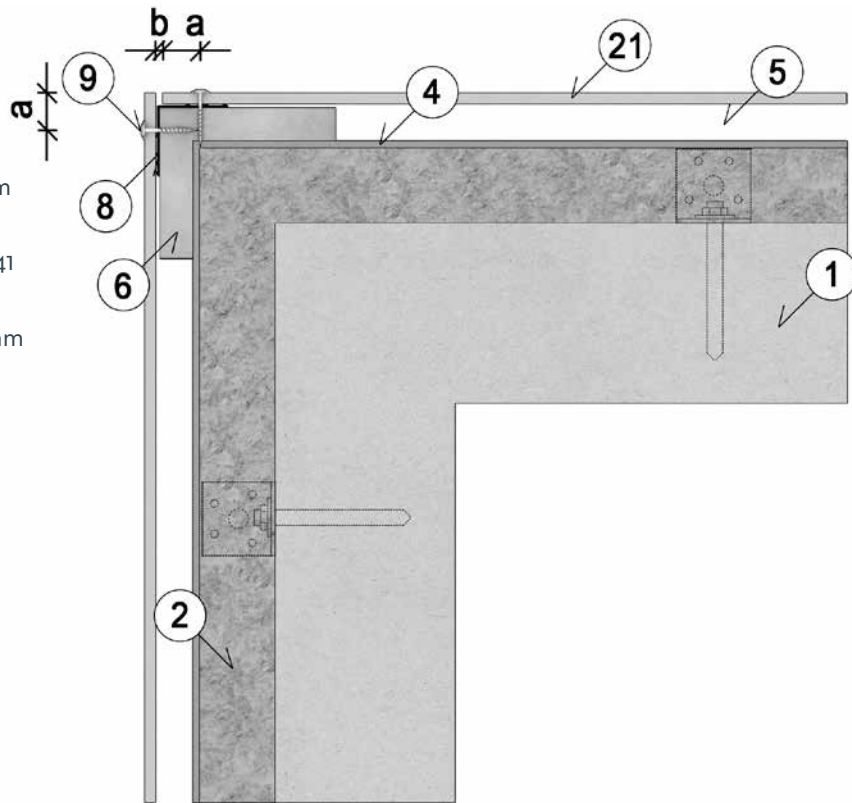

Horizontal cross section internal corner

- 31 Load bearing wall
- 2 Insulation
- 4 Wind break
- 5 Air gap min 20 mm
- 6 Batten min 20 x 100 mm
- 8 EPDM underlay
- 9 Facade screw 4.5 x 36/41
- 21 Facade board
- a Edge distance 25-150 mm
- b Joint width 8 mm

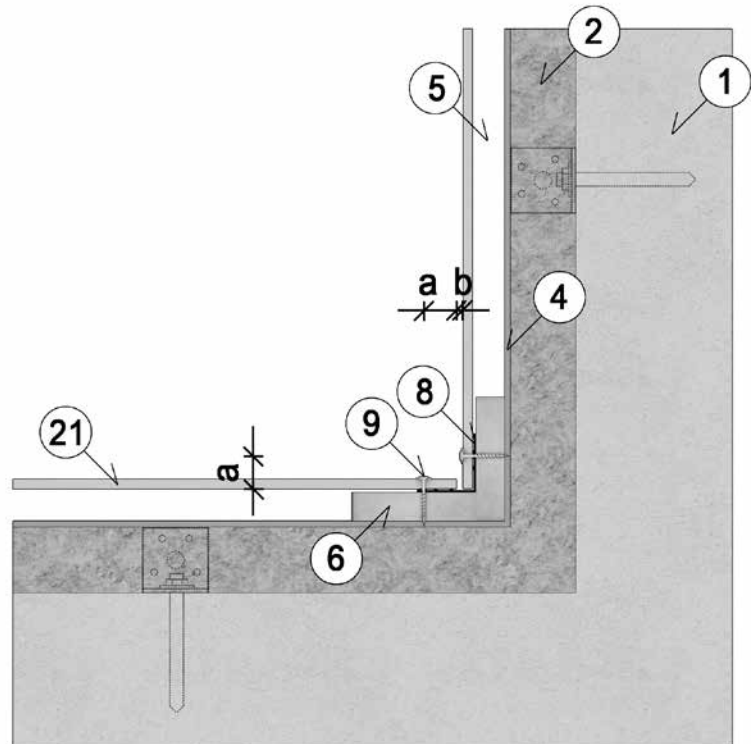



Horizontal cross section window

(Window recess max. 200 mm without ventilation)

- 31 Load bearing wall
- 2 Insulation
- 4 Wind break
- 5 Air gap min 20 mm
- 6 Batten min 20 x 100 mm
- 8 EPDM underlay
- 9 Facade screw 4.5 x 36/41
- 21 Facade board
- 22 Window
- a Edge distance 25-150 mm
- b Joint width 8 mm

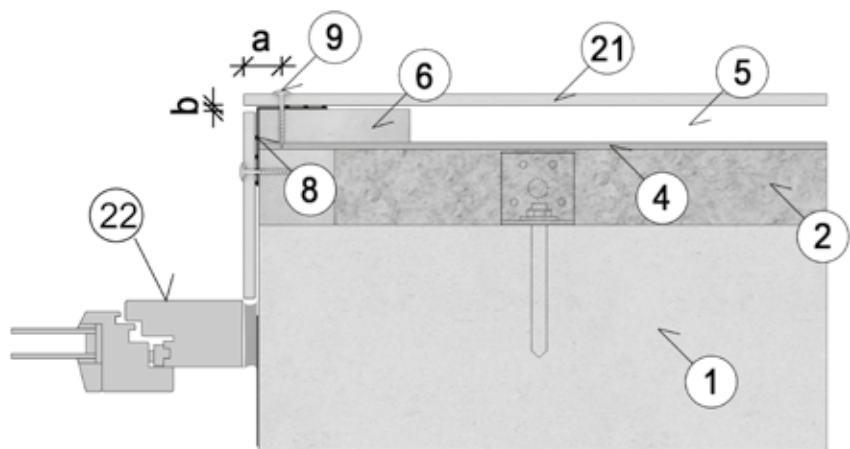

Screws on wooden sub-constructions

Vertical cross section horizontal joint

- 1 Load bearing wall
- 2 Insulation
- 4 Wind break
- 5 Air gap min 20 mm
- 8 EPDM underlay
- 9 Facade screw 4.5 x 36/41
- 21 Facade board
- b Joint width 8 mm
- c Corner distance 100-150 mm

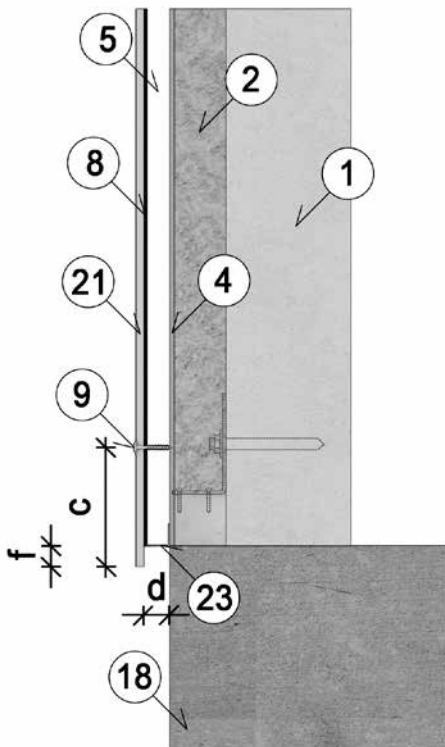
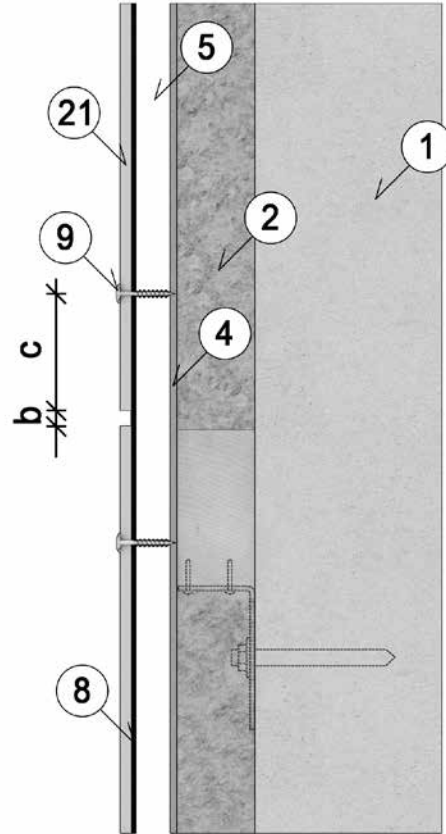

Vertical cross section foundation

- 31 Load bearing wall
- 2 Insulation
- 4 Wind break
- 5 Air gap min 20 mm
- 8 EPDM underlay
- 9 Facade screw 4.5 x 36/41
- 18 Foundation
- 21 Facade board
- 23 Insect grating
- c Corner distance 100-150 mm
- d Ventilation inlet min 100 cm²/m
- f Overhang approx. 30 mm

Screws on wooden sub-constructions

Vertical cross section roof edge

- 31 Load bearing wall
- 2 Insulation
- 4 Wind break
- 5 Air gap min 20 mm
- 8 EPDM underlay
- 9 Facade screw 4.5 x 36/41
- 21 Facade board
- c Corner distance 100-150 mm
- d Ventilation outlet min 100 cm²/m
- f Overhang approx. 30 mm

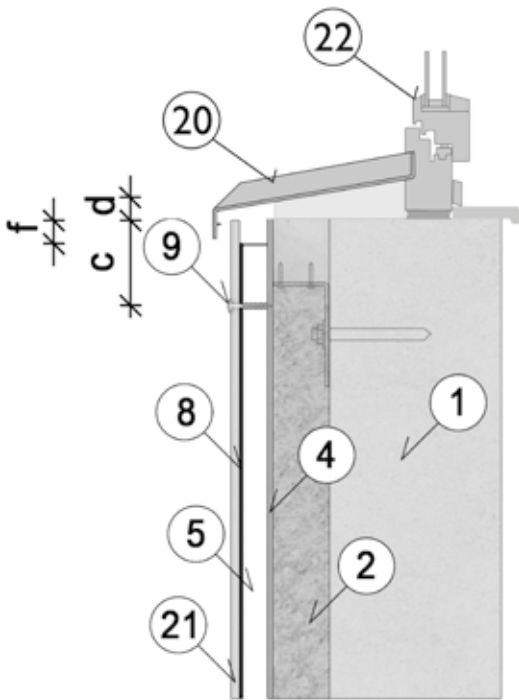
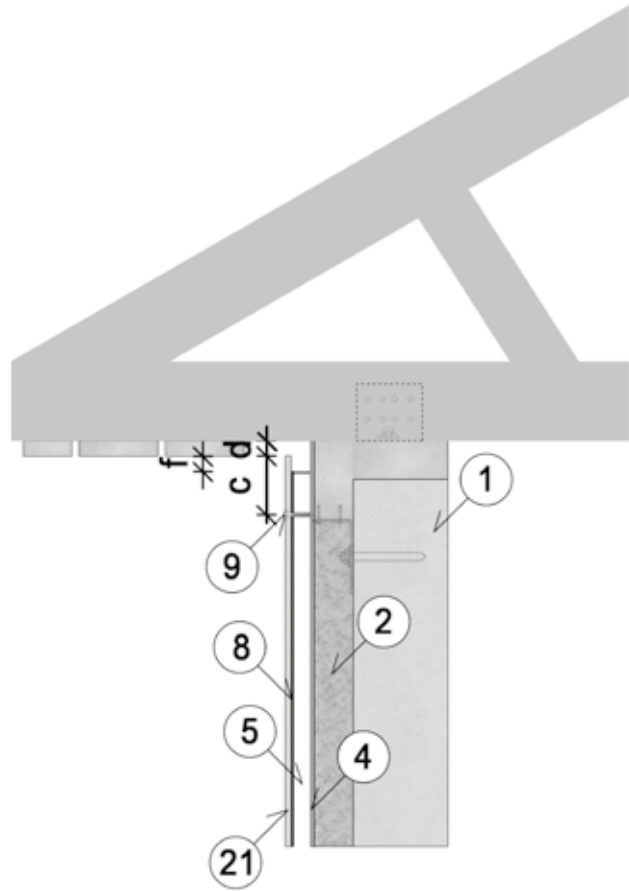

Vertical cross section window sill

- 31 Load bearing wall
- 2 Insulation
- 4 Wind break
- 5 Air gap min 20 mm
- 8 EPDM underlay
- 9 Facade screw 4.5 x 36/41
- 20 Window sill
- 21 Facade board
- 22 Window
- c Corner distance 100-150 mm
- d Ventilation outlet min 100 cm²/m
- f Overhang approx. 30 mm

Screws on wooden sub-constructions

Vertical cross section window upper edge (Window recess max 200 mm without ventilation)

- 31 Load bearing wall
- 2 Insulation
- 4 Wind break
- 5 Air gap min 20 mm
- 7 EPDM underlay
- 9 Facade screw 4.5 x 36/41
- 21 Facade board
- 22 Window
- 23 Insect grating
- c Corner distance 100-150 mm
- d Ventilation inlet min 100 cm²/m
- f Overhang approx. 30 mm

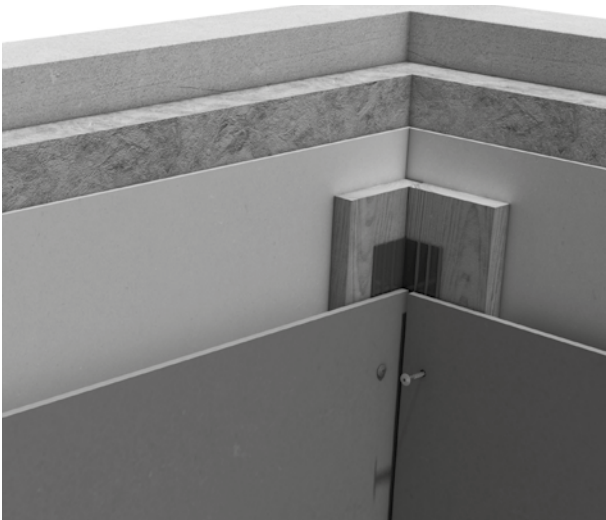
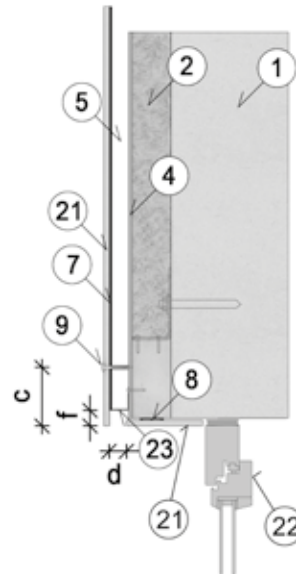

Internal corner

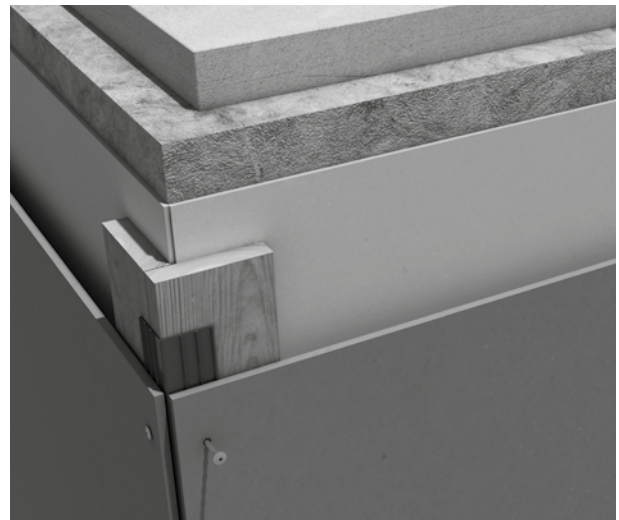

External corner

Ceiling

Facade boards may also be installed as under-cladding or ceiling. The installation principles are the same as for vertical installation. Edge distance for screws 25 mm. Corner distance 100 mm. Max support and fixing distances 400 mm.

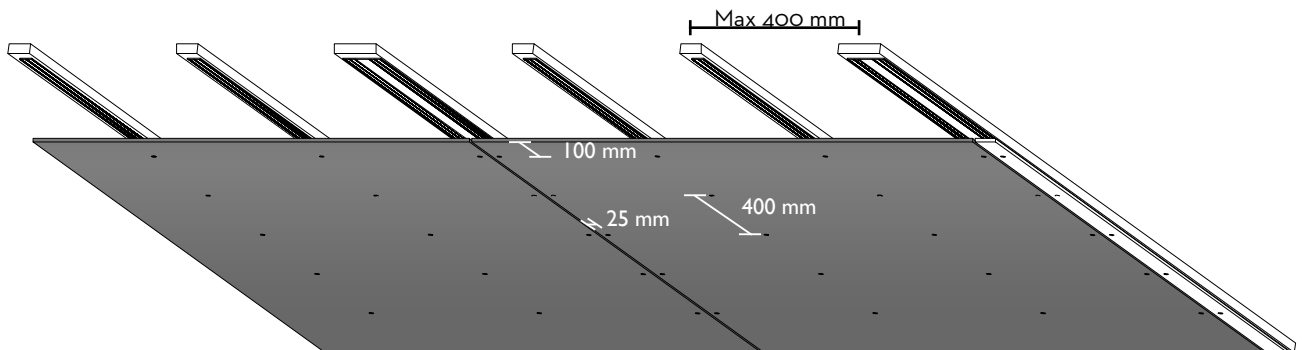

Rivets on aluminium

Front view

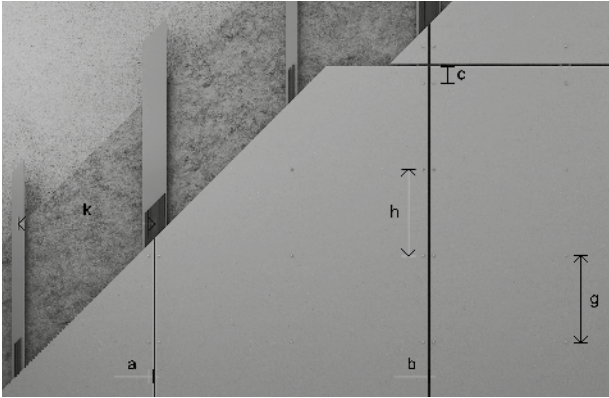

Ceiling

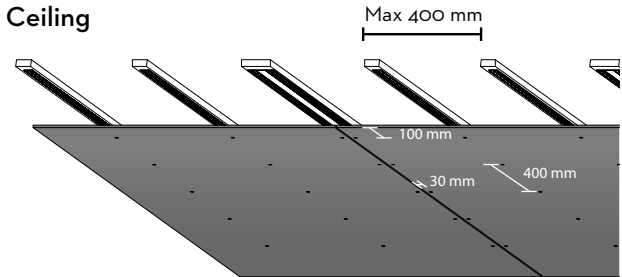

In order to achieve a correct and safe aluminium sub-construction, the supplier of the system should be consulted. However, there are a few rules to consider when it comes to the functionality of the facade boards:

- Length of the aluminium profiles is maximum 3000 mm (one storey)
- The aluminium profiles must be fixed with one fix-point at the middle or the upper end and all other fixations as sliding points
- All joints of the aluminium profiles must be aligned so they can be followed by joints of the facade boards. A board must never cross an aluminium profile joint and be fixed to two separate aluminium profiles across a joint
- The facade boards must be fixed with a fix-point in the middle of the board. All other fixations are sliding points. In case of two intermediate supporting profiles, two fix-points at the same horizontal level are allowed
- Every 12 m of the facade a double framing must be installed in order to create a dilatation joint.
- **Important!** With installation with rivets, begin with the fix-points, followed by the sliding points above and finally the sliding points below.

On metal sub-construction, the length of the Cembrit Raw boards must not exceed 1500 mm.

Fixing details

Vertical board orientation

Installation with rivets on aluminium, vertical sub-construction

Max dimensions 8 x 1250 x 1500 mm

Drill hole in the boards: Ø9

Wind load	Max support distance	Max fixing distance	Edge distance	Corner distance
kN/m ²	k mm	h, g mm	a mm	c mm
0.60	630	600	30-150	100-150*
0.70	630	600		
0.80	630	600		
0.90	630	600		
1.00	630	500		
1.10	630	500		
1.20	630	400		
1.30	420	500		
1.40	420	500		
1.50	420	500		
1.60	420	500		
1.70	420	450		
1.80	420	400		
1.90	420	400		
2.00	420	400		

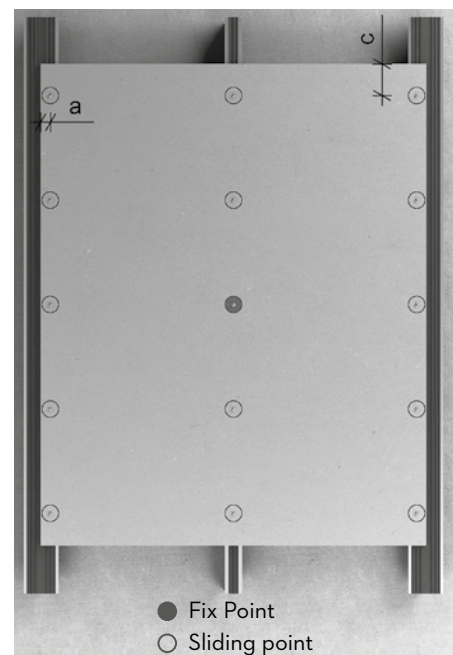

*Overhang e.g. windows max 200 mm

Rivets on aluminium

Horizontal orientation

Facade boards may be installed in a horizontal position on a vertical sub-structure.

On aluminium framing, the edge distance $a \geq 30$ mm and corner distance $c \geq 100$ mm.

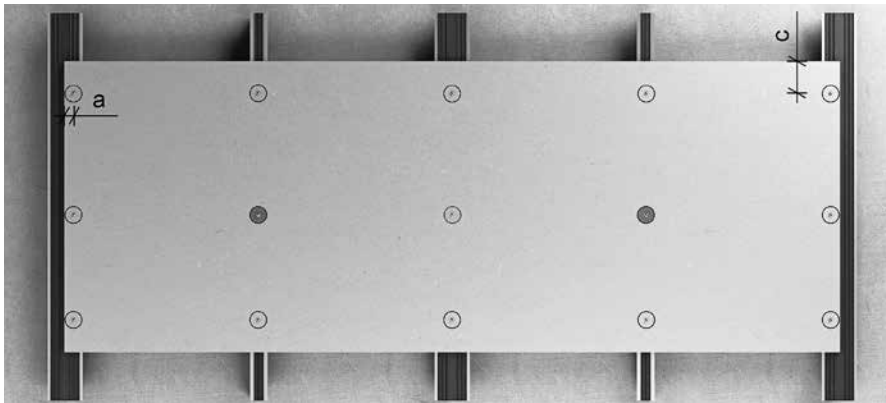

- Fix Point
- Sliding point

Horizontal board orientation

Installation with rivets on aluminium, vertical sub-construction

Max dimensions 8 x 1250 x 1500 mm

Drill hole in the boards: $\varnothing 9$

Wind load	Max support distance	Max fixing distance	Edge distance	Corner distance
kN/m ²	k mm	h, g mm	a mm	c mm
0.60	630	600	30-150	100-150*
0.70	630	600		
0.80	630	600		
0.90	630	600		
1.00	500	500		
1.10	500	500		
1.20	500	500		
1.30	500	500		
1.40	500	400		
1.50	440	400		
1.60	440	400		
1.70	440	400		
1.80	420	400		
1.90	420	400		
2.00	420	400		

*Overhang e.g. windows max 200 mm

Rivets on aluminium

Horizontal cross section vertical joint

- 1 Load bearing wall
- 3 Insulation
- 5 Air gap min 20 mm
- 8 EPDM underlay
- 11 Rivet 4.0x20
- 16 Aluminium frame system
- 21 Facade board
- a Edge distance min 30 mm
- b Joint width 8 mm

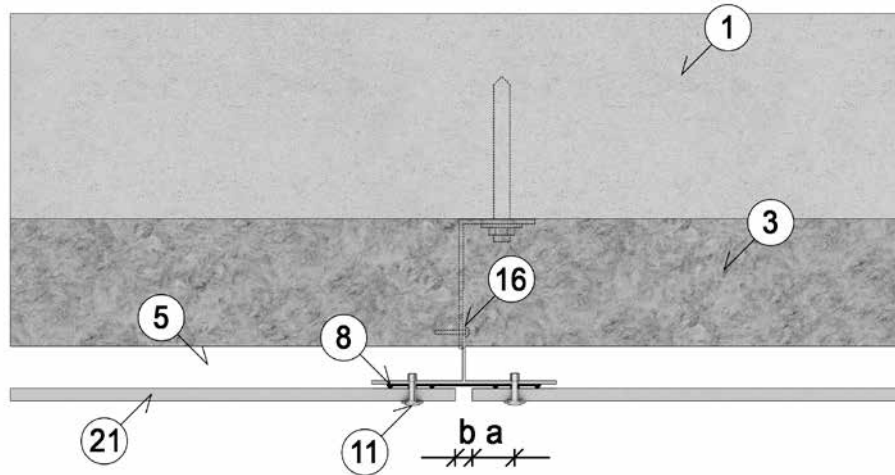

Horizontal cross section intermediate support

- 1 Load bearing wall
- 3 Insulation
- 5 Air gap min 20 mm
- 7 EPDM underlay
- 11 Rivet 4.0x20
- 16 Aluminium frame system
- 21 Facade board

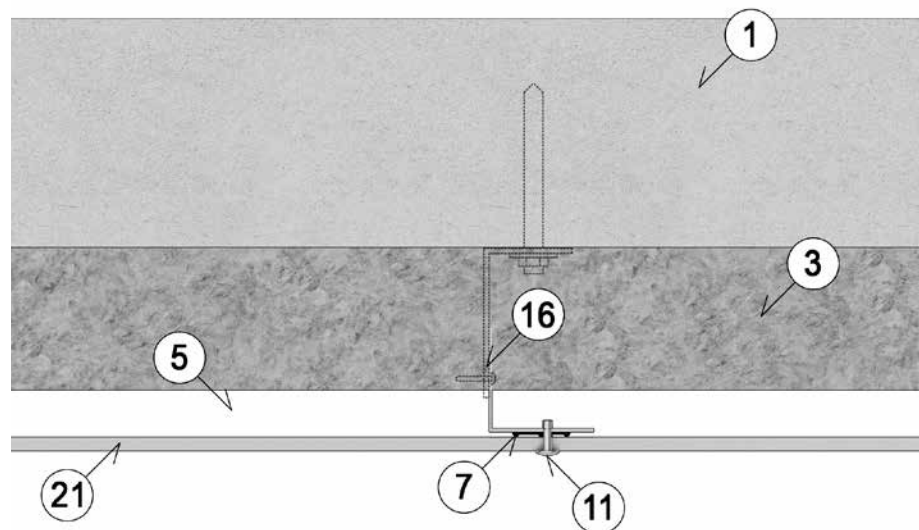

Rivets on aluminium

Horizontal cross section external corner

- 1 Load bearing wall
- 3 Insulation
- 5 Air gap min 20 mm
- 7 EPDM underlay
- 8 EPDM underlay
- 11 Rivet 4.0x20
- 16 Aluminium frame system
- 17 Aluminium angle
- 21 Facade board
- a Edge distance min 30 mm
- b Joint width 8 mm
- e Dist. to wall fixing max 200 mm

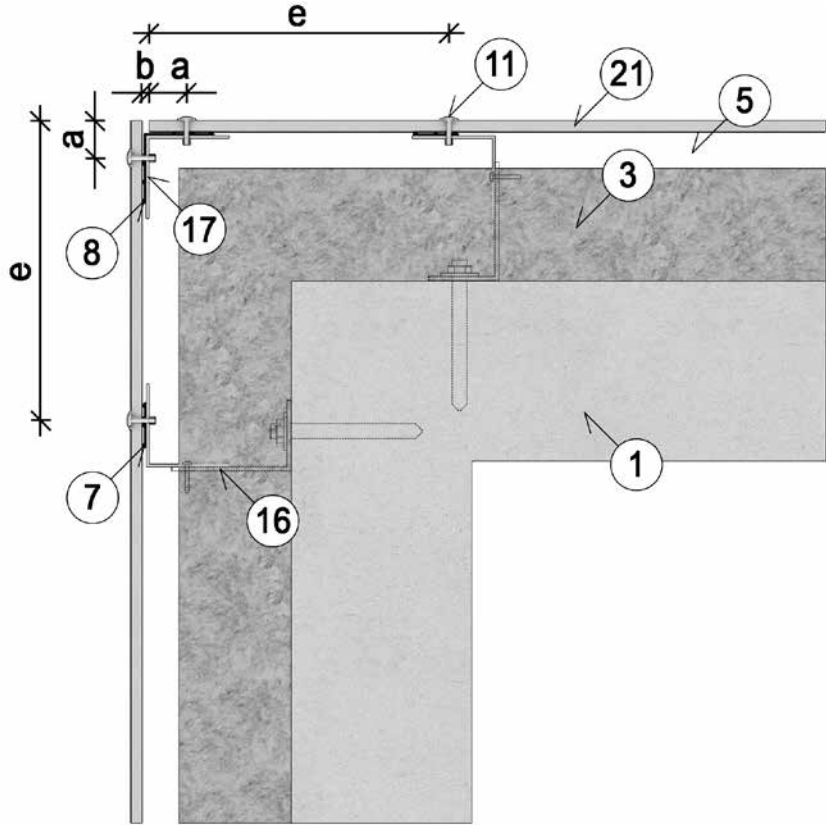

Horizontal cross section internal corner

- 1 Load bearing wall
- 3 Insulation
- 5 Air gap min 20 mm
- 7 EPDM underlay
- 8 EPDM underlay
- 11 Rivet 4.0x20
- 16 Aluminium frame system
- 17 Aluminium angle
- 21 Facade board
- a Edge distance min 30 mm
- b Joint width 8 mm

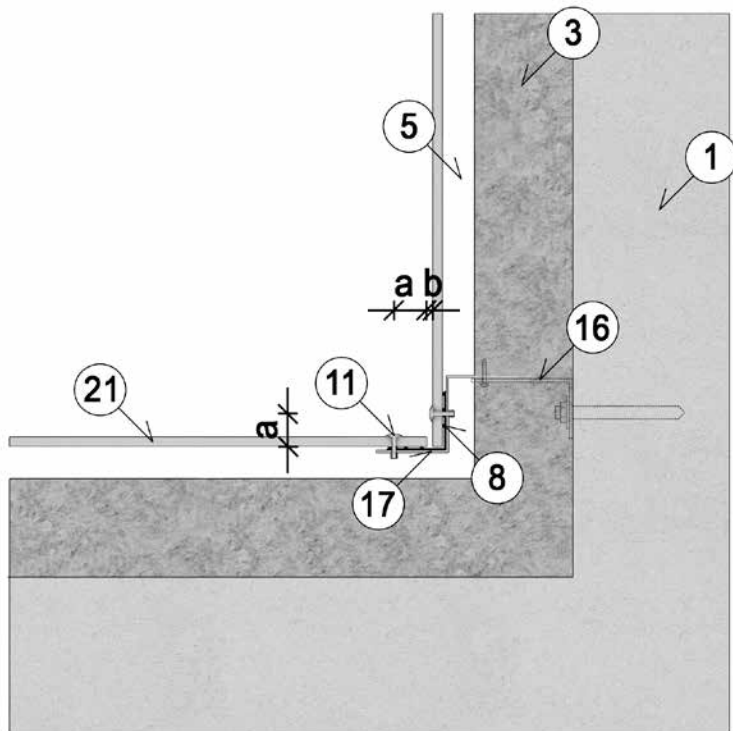

Rivets on aluminium

Horizontal cross section window

(Window recess max 200 mm without ventilation)

- 1 Load bearing wall
- 3 Insulation
- 5 Air gap min 20 mm
- 7 EPDM underlay
- 8 EPDM underlay
- 11 Rivet 4.0x20
- 16 Aluminium frame system
- 17 Aluminium angle
- 21 Facade board
- 22 Window
- a Edge distance min 30 mm
- b Joint width 8 mm

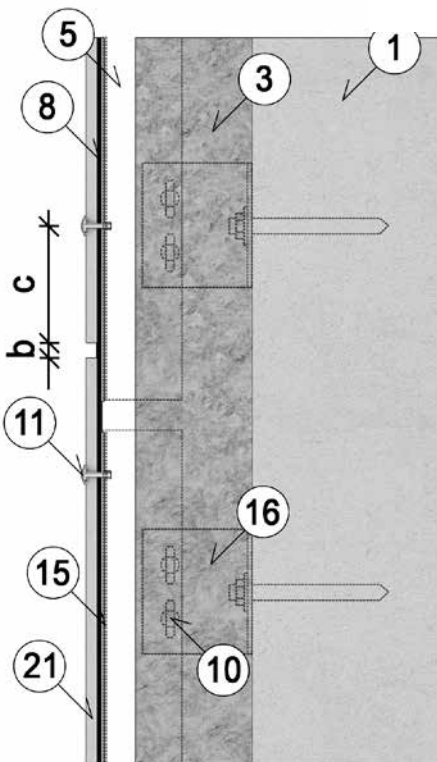
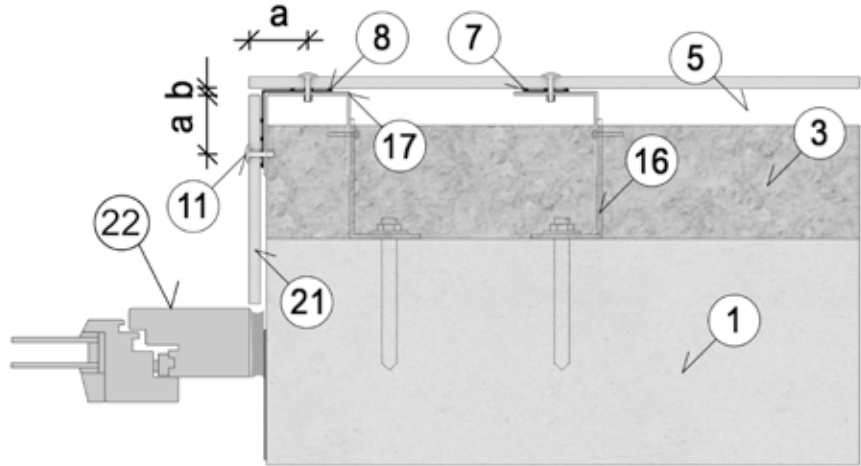

Vertical cross section horizontal joint

- 1 Load bearing wall
- 3 Insulation
- 5 Air gap min 20 mm
- 8 EPDM underlay
- 10 Fixing point profile/bracket
- 11 Rivet 4.0x20
- 15 Aluminium profile
- 16 Aluminium frame system
- 21 Facade board
- b Joint width 8 mm
- c Distance min 100 mm

Note! Boards must never be fixed to two separate profiles!

Rivets on aluminium

Vertical cross section foundation

- 1 Load bearing wall
- 3 Insulation
- 5 Air gap min 2 mm
- 8 EPDM underlay
- 10 Fixing point profile/bracket
- 11 Rivet 4.0x20
- 15 Aluminium profile
- 16 Aluminium frame system
- 18 Foundation
- 21 Facade board
- 23 Insect grating
- c Corner distance 100-150 mm
- d Ventilation inlet min 100cm²/m
- f Overhang approx. 30 mm

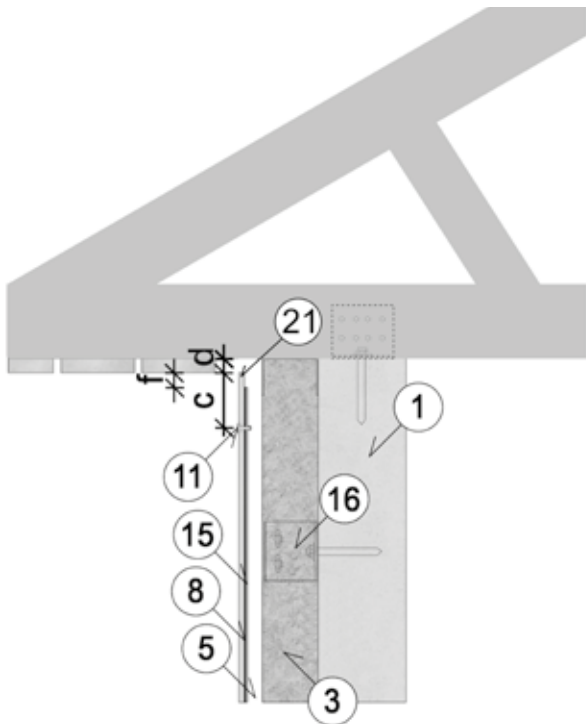
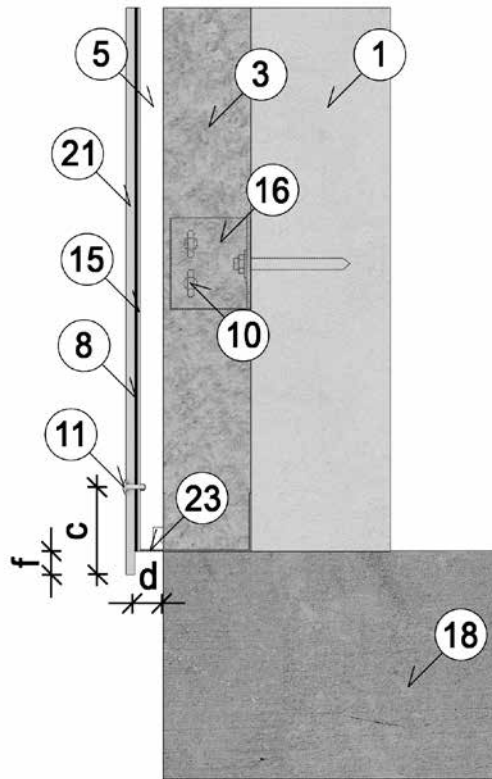

Vertical cross section roof edge

- 1 Load bearing wall
- 3 Insulation
- 5 Air gap min 20 mm
- 8 EPDM underlay
- 11 Rivet 4.0x20
- 15 Aluminium profile
- 16 Aluminium frame system
- 21 Facade board
- c Corner distance 100-150 mm
- d Ventilation outlet min 100cm²/m
- f Overhang approx. 30 mm

Rivets on aluminium

Vertical cross section window sill

- 1 Load bearing wall
- 3 Insulation
- 5 Air gap min 20 mm
- 8 EPDM underlay
- 11 Rivet 4.0x20
- 15 Aluminium profile
- 16 Aluminium frame system
- 20 Window sill
- 21 Facade board
- 22 Window
- c Corner distance 100-150 mm
- d Ventilation outlet min 100cm²/m
- f Overhang approx. 30 mm

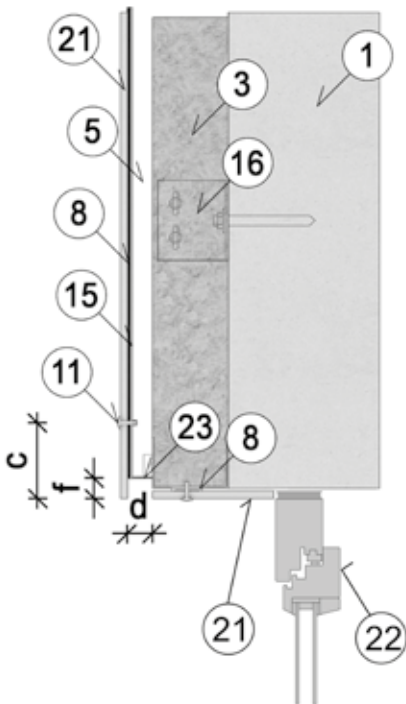
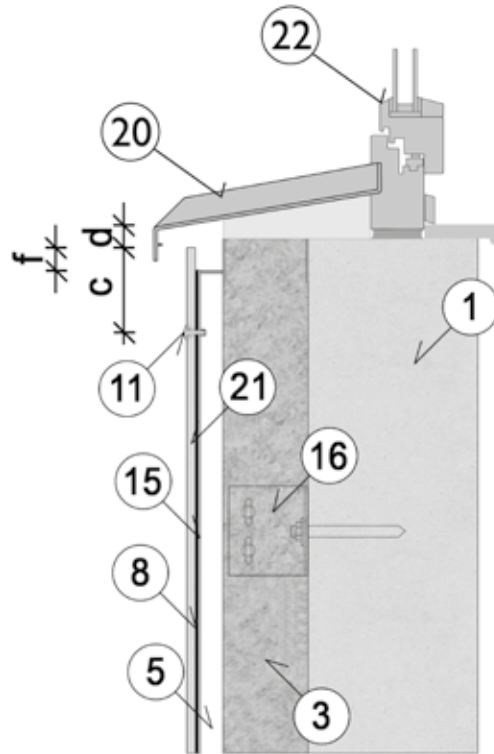

Vertical cross section window upper edge

(Window recess max 200 mm without ventilation)

- 1 Load bearing wall
- 3 Insulation
- 5 Air gap min 20 mm
- 8 EPDM underlay
- 11 Rivet 4.0x20
- 15 Aluminium profile
- 16 Aluminium frame system
- 21 Facade board
- 22 Window
- 23 Insect grating
- c Corner distance 100-150 mm
- d Ventilation inlet min 100cm²/m
- f Overhang approx. 30 mm

Screws and rivets on steel sub-construction

In order to achieve a correct and safe steel sub-construction, the supplier of the system should be consulted. However, there are a few rules to consider when it comes to the functionality of the facade boards:

- Length of the steel profiles is maximum 3000 mm (one storey)
- The steel profiles must be fixed with one fix-point at the middle or the upper end and all other fixations as sliding points
- All joints of the steel profiles must be aligned allowing them to be followed by joints of the facade boards. A board must never cross a joint in the steel profiles. A board must never cross a steel profile joint and be fixed to two separate steel profiles across a joint
- The facade boards must be fixed with a fix-point in the middle of the board. All other fixations are sliding points. In case of two intermediate supporting profiles, two fix-points at the same horizontal level are allowed
- Every 12 m of the facade a double framing must be installed in order to create a dilatation joint.
- Important! Fasten the boards at the fix-point(s), followed by the sliding points above and finally the sliding points below.

(The following illustrations show installation with screws - details are similar for rivets)

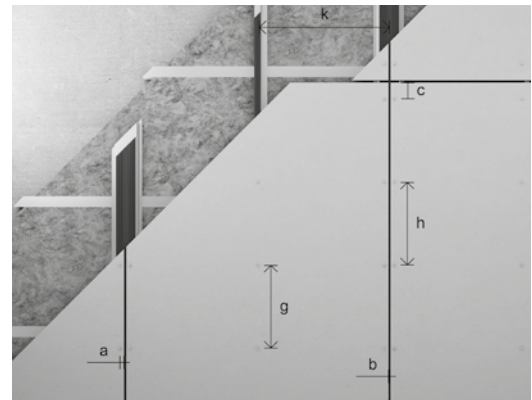
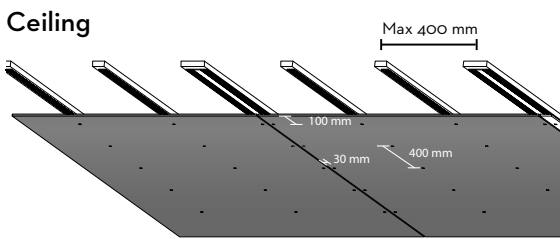

Fixing details

Vertical board orientation

Installation on steel, vertical sub-construction

Max dimensions 8 x 1250 x 1500 mm

Drill hole in the boards - rivets: Ø9

Drill hole in the boards - screws: Ø8

Wind load	Max support distance	Max fixing distance	Edge distance	Corner distance
kN/m ²	k mm	h, g mm	a mm	c mm
0.60	630	600	30-150	100-150*
0.70	630	600		
0.80	630	600		
0.90	630	600		
1.00	630	500		
1.10	630	500		
1.20	630	400		
1.30	420	500		
1.40	420	500		
1.50	420	500		
1.60	420	500		
1.70	420	450		
1.80	420	400		
1.90	420	400		
2.00	420	400		

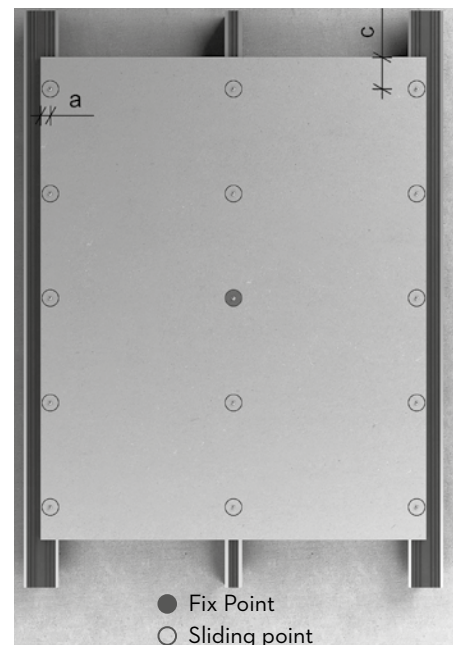

*Overhang e.g. windows max 200 mm

Screws and rivets on steel sub-construction

Horizontal orientation

Facade boards may be installed in a horizontal position on a vertical sub-structure. On metal framing, the edge distance must be $a \geq 30$ mm and corner distance $c \geq 100$ mm.

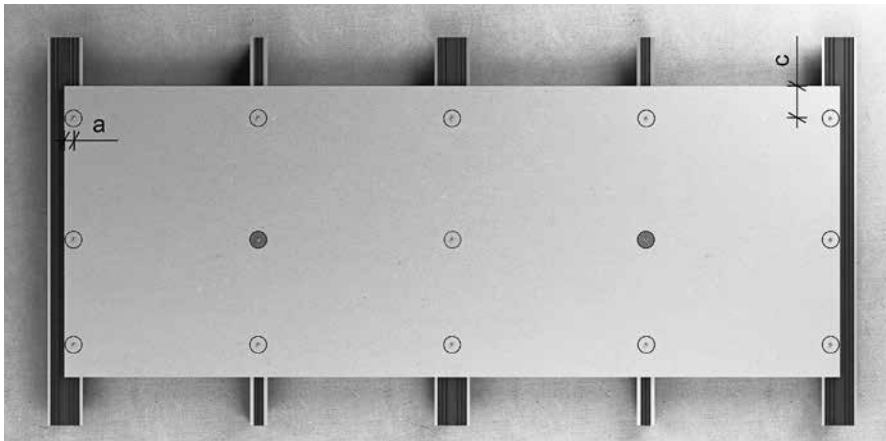

- Fix Point
- Sliding point

Horizontal board orientation

Installation on steel, vertical sub-construction

Max dimensions 8 x 1250 x 1500 mm

Drill hole in the boards: Ø8

Wind load	Max support distance	Max fixing distance	Edge distance	Corner distance
kN/m ²	k mm	h, g mm	a mm	c mm
0.60	630	600	30-150	100-150*
0.70	630	600		
0.80	630	600		
0.90	630	600		
1.00	500	500		
1.10	500	500		
1.20	500	500		
1.30	500	500		
1.40	500	400		
1.50	440	400		
1.60	440	400		
1.70	440	400		
1.80	420	400		
1.90	420	400		
2.00	420	400		

*Overhang e.g. windows max 200 mm

Screws and rivets on steel sub-construction

Horizontal cross section vertical joint

- 1 Load bearing wall
- 3 Insulation
- 5 Air gap min 20 mm
- 8 EPDM underlay
- 9 Facade screw 4.8x25
- 21 Facade board
- 24 Steel profile
- a Edge distance min 30 mm
- b Joint width 8 mm

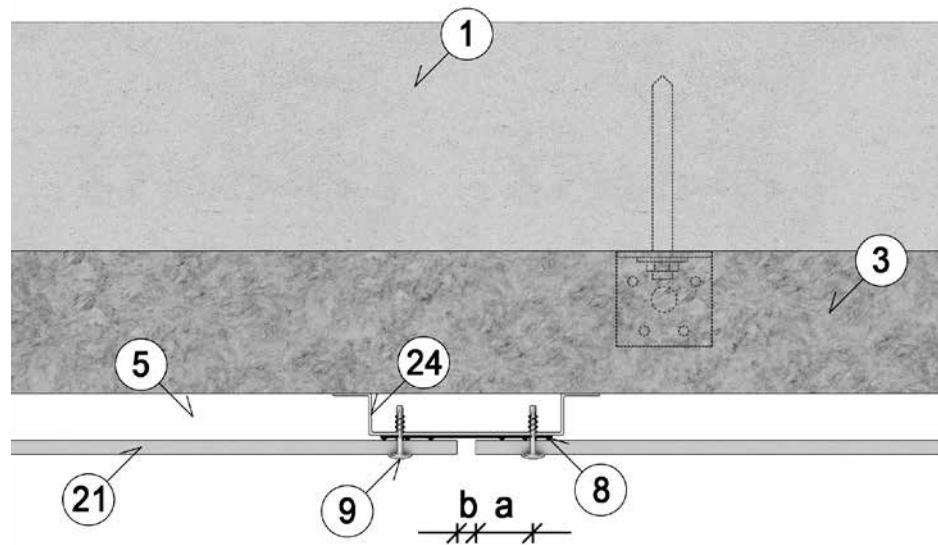

Horizontal cross section intermediate support

- 31 Load bearing wall
- 3 Insulation
- 5 Air gap min 20 mm
- 8 EPDM underlay
- 9 Facade screw 4.8x25
- 21 Facade board
- 24 Steel profile

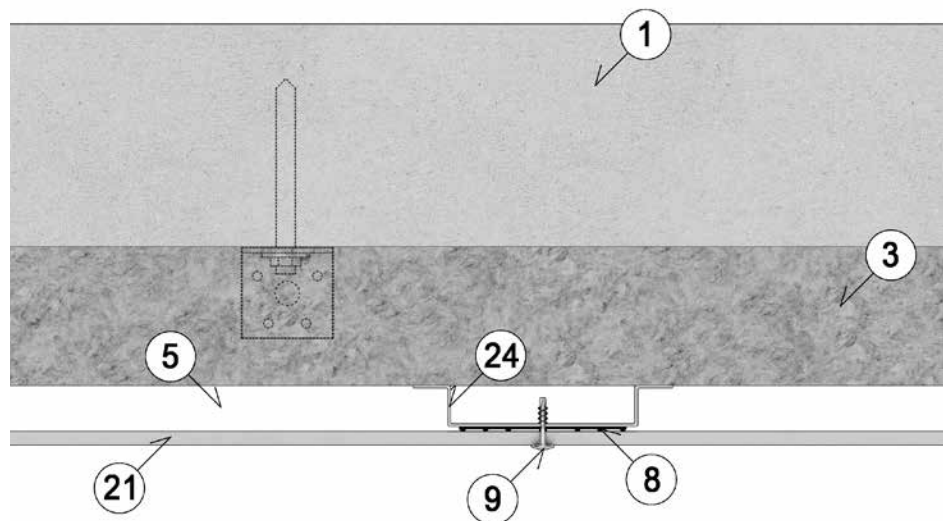

Screws and rivets on steel sub-construction

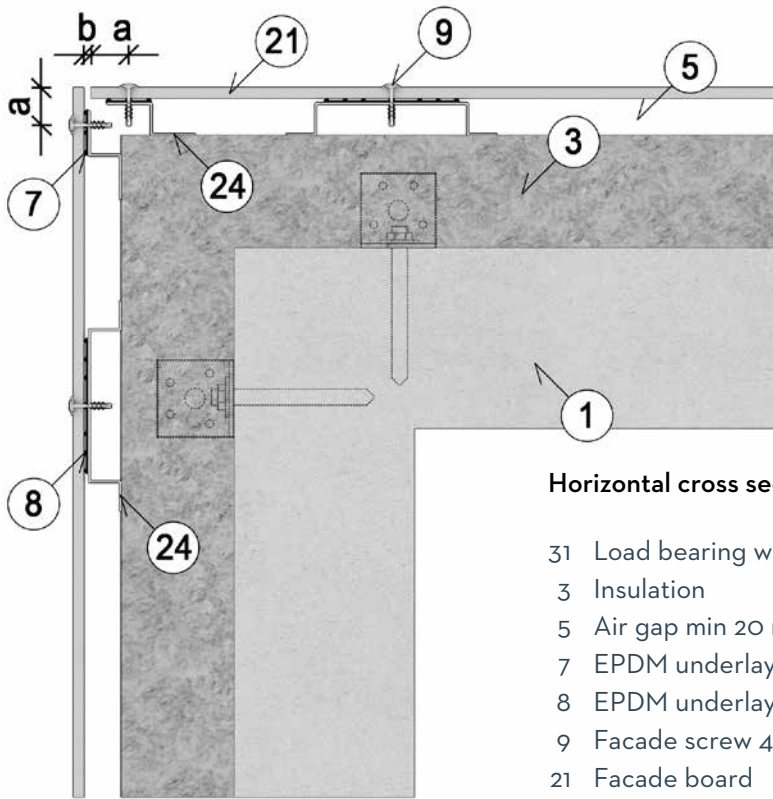

Horizontal cross section external corner

- 31 Load bearing wall
- 3 Insulation
- 5 Air gap min 20 mm
- 7 EPDM underlay
- 8 EPDM underlay
- 9 Facade screw 4.8x25
- 21 Facade board
- 24 Steel profile
- a Edge distance min 30 mm
- b Joint width 8 mm

Horizontal cross section internal corner

- 31 Load bearing wall
- 3 Insulation
- 5 Air gap min 20 mm
- 7 EPDM underlay
- 8 EPDM underlay
- 9 Facade screw 4.8x25
- 21 Facade board
- 24 Steel profile
- a Edge distance min 30 mm
- b Joint width 8 mm

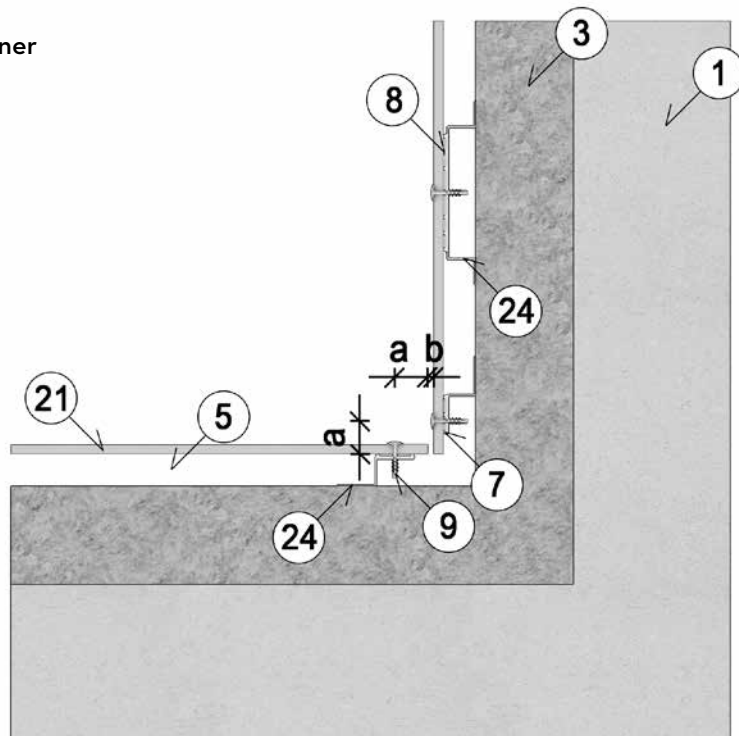

Screws and rivets on steel sub-construction

Horizontal cross section window

(Window recess max 200 mm without ventilation)

- 31 Load bearing wall
- 3 Insulation
- 5 Air gap min 20 mm
- 8 EPDM underlay
- 9 Facade screw 4.8x25
- 21 Facade board
- 22 Window
- 24 Steel profile
- a Edge distance min 30 mm
- b Joint width 8 mm

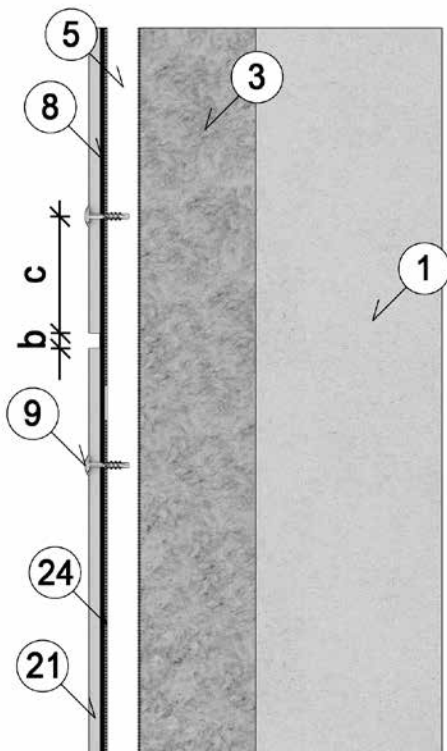
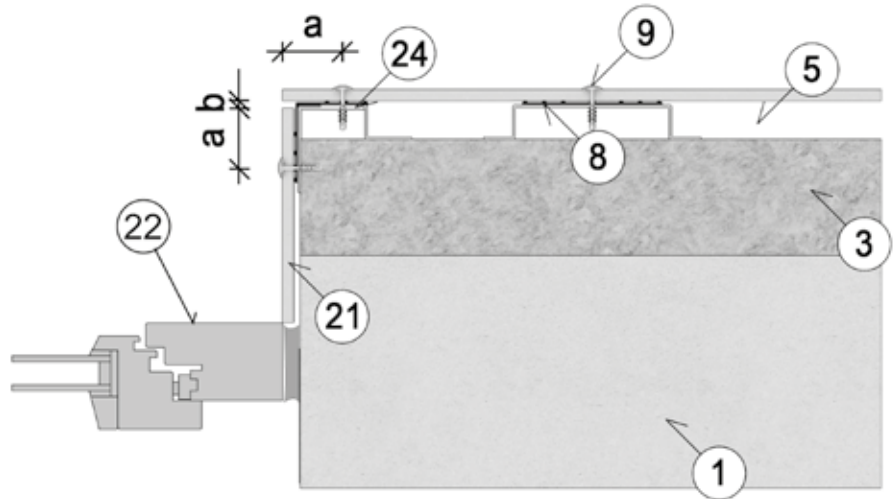

Vertical cross section horizontal joint

- 1 Load bearing wall
- 3 Insulation
- 5 Air gap min 20 mm
- 8 EPDM underlay
- 9 Facade screw 4.8x25
- 21 Facade board
- 24 Steel profile
- b Joint width 8 mm
- c Corner distance min 100 mm

Screws and rivets on steel sub-construction

Vertical cross section foundation

- 31 Load bearing wall
- 3 Insulation
- 5 Air gap min 20 mm
- 8 EPDM underlay
- 9 Facade screw 4.8x25
- 18 Foundation
- 21 Facade board
- 23 Insect grating
- 24 Steel profile
- c Corner distance 100-150 mm
- d Ventilation inlet min 100 cm²/m
- f Overhang approx. 30 mm

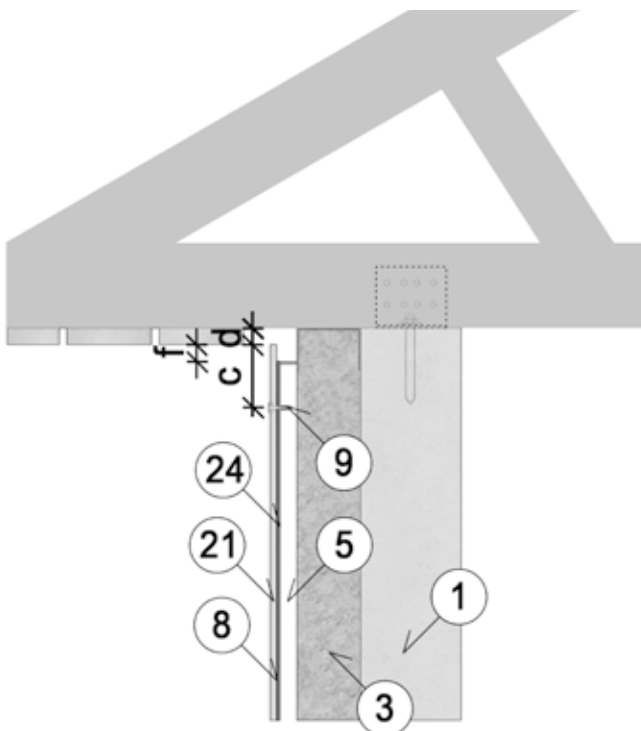
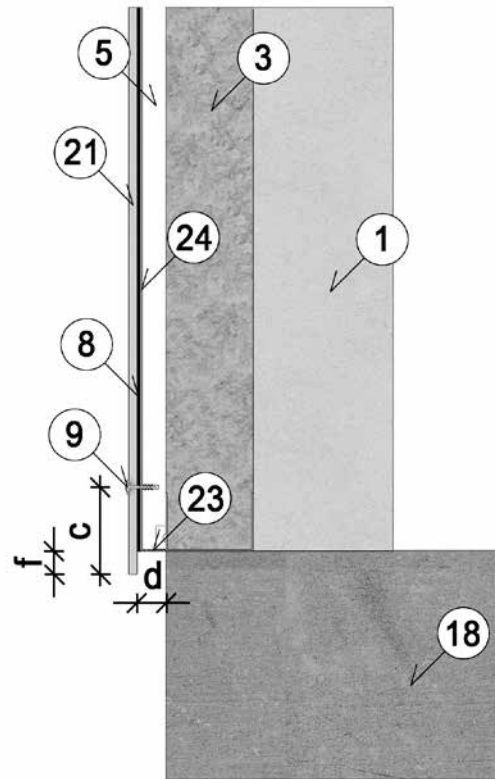

Vertical cross section roof edge

- 31 Load bearing wall
- 3 Insulation
- 5 Air gap min 20 mm
- 8 EPDM underlay
- 9 Facade screw 4.8x25
- 19 Eave
- 21 Facade board
- 24 Steel profile
- c Corner distance 100-150 mm
- d Ventilation outlet min 100 cm²/m
- f Overhang approx. 30 mm

Screws and rivets on steel sub-construction

Vertical cross section window sill

- 31 Load bearing wall
- 3 Insulation
- 5 Air gap min 20 mm
- 8 EPDM underlay
- 9 Facade screw 4.8x25
- 20 Window sill
- 21 Facade board
- 22 Window
- 24 Steel profile
- c Corner distance 100-150 mm
- d Ventilation outlet min 100 cm²/m
- f Overhang approx. 30 mm

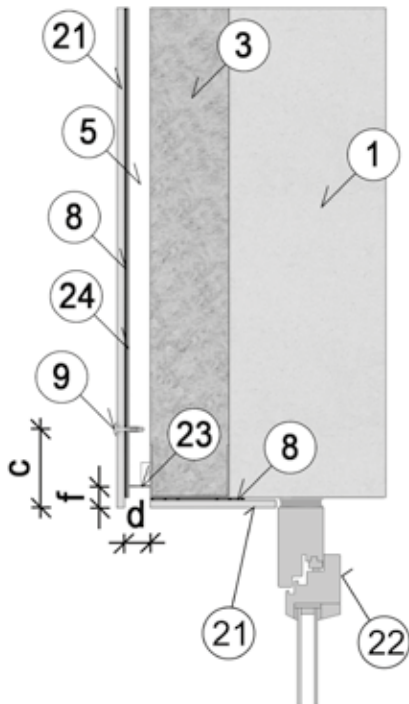
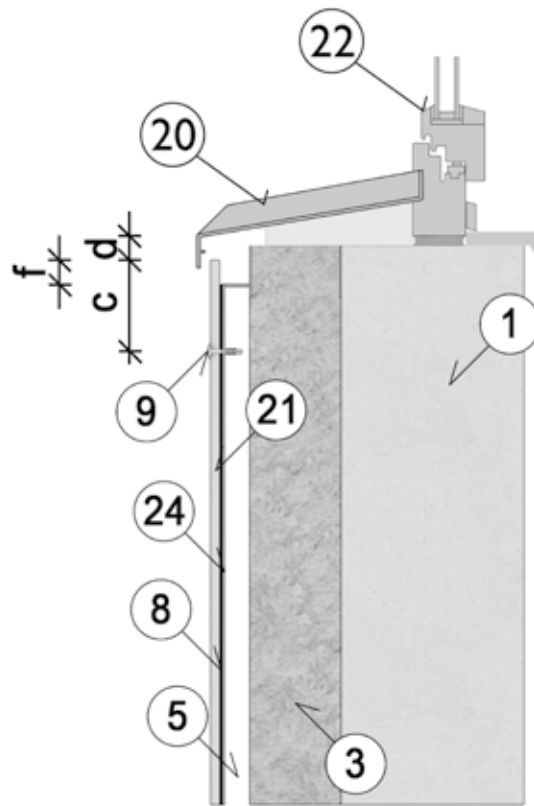

Vertical cross section window upper edge

(Window recess max 200 mm without ventilation)

- 31 Load bearing wall
- 3 Insulation
- 5 Air gap min 20 mm
- 8 EPDM underlay
- 9 Facade screw 4.8x25
- 21 Facade board
- 22 Window
- 23 Insect grating
- 24 Steel profile
- c Corner distance 100-150 mm
- d Ventilation inlet min 100 cm²/m
- f Overhang approx. 30 mm

Weatherboards

Weatherboards are very much used on dormers, eaves, gables, carports, etc. They can be fixed on vertical as well as horizontal sub-constructions. Visible fixing and invisible, concealed fixing are possible. Weatherboards can be cut to size on site, or they can be ordered cut to size from Cembrit. Note! The table below covers weatherboards up to a width of 300 mm with a single side fixing. Wider boards should be fixed with double sided fixing according to with the fixing details in the table page 9.

With this installation method, the board length is limited to max 2500 mm.

Fixing details for vertical sub-construction

Board Thickness mm	Max support distance	Min edge distances		Drill holes in board	
		a mm	m mm	Screws on wood and steel	Rivets on aluminium and steel
8	400	25 on wood 30 on aluminium and steel	40	Ø8 on wood and steel	Ø9

Front view

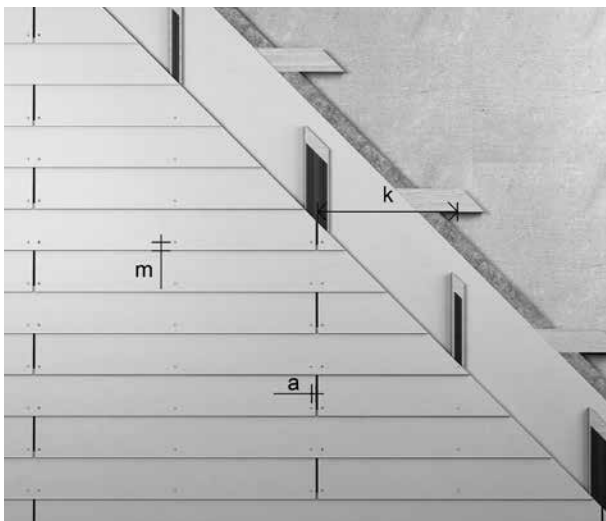

Vertical sub-construction - visible fixing

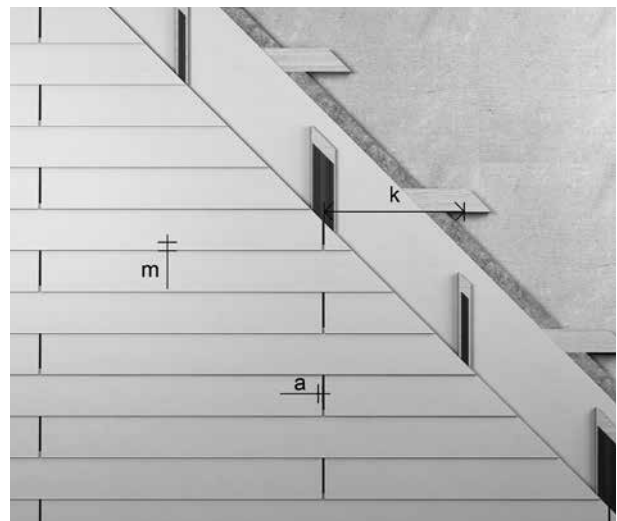

Vertical sub-construction - invisible, concealed fixing

Weatherboards

Horizontal cross section vertical joint

- 1 Load bearing wall
- 2 Insulation
- 4 Wind break
- 5 Air gap min 20 mm
- 6 Batten min 20 x 100 mm planed
- 8 EPDM underlay
- 9 Facade screw
- 21 Facade board
- a Edge distance min 25 mm
- b Joint width 8 mm

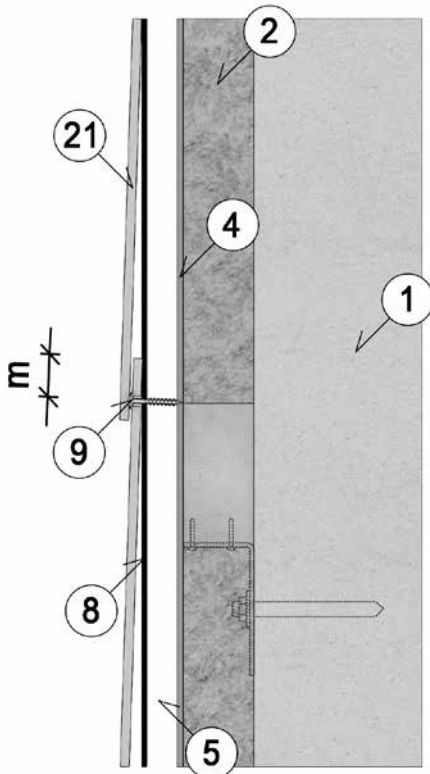
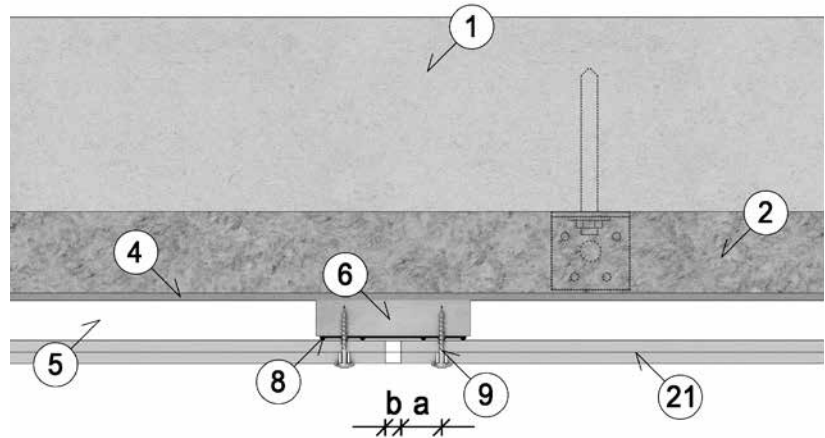

Vertical cross section invisible, concealed fixing

- 1 Load bearing wall
- 2 Insulation
- 4 Windbreak
- 5 Air gap min 20 mm
- 8 EPDM underlay
- 9 Facade screw
- 21 Facade board
- m Edge distance min 40 mm

Weatherboards

Vertical cross section visible fixing

- 1 Load bearing wall
- 2 Insulation
- 4 Windbreak
- 5 Air gap min 20 mm
- 8 EPDM underlay
- 9 Facade screw
- 21 Facade board
- m Edge distance min 40 mm

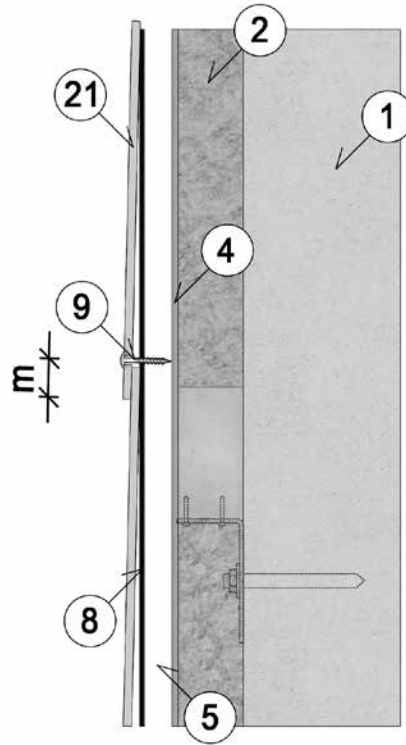

Care & Maintenance

On-site

Cleaning of boards after cutting and drilling

It is important to immediately remove dust caused by cutting and drilling from the front and rear of the boards with a soft brush/duster or a vacuum cleaner, as it otherwise might damage the boards. Ensure that the boards are properly cleaned before installation, and if necessary use clean water or water with a mild detergent and a soft sponge or brush to remove dirt and dust from the surface. Thereafter, wipe the boards with a damp cloth. It may also be necessary to wash the surface after installation, if the building site conditions have been unfavourable. This is done with lots of clean water or water with a mild detergent and a soft sponge or brush and finally wiping the boards with a damp cloth.

Removal of calcium based residues

Calcium carbonate residue may occasionally be seen on the board surface. This can be difficult to remove with water or even with detergents, because it does not dissolve in water. For cleaning purposes 10% acetic acid (>CH₃COOH) solution is used to dissolve the calcium compounds.

Note! Carefully observe safety precautions (MSDS) when working with acetic acid. R-phrase R36/R38 is valid: "Irritating to eyes, respiratory system and skin". Use proper clothing, nitrile rubber gloves, eye protection goggles and approved respirator (filter A, E or A/E).

Carry out the mixing outdoors. Apply the diluted 10% acetic acid solution evenly with a spray can to the surface of the stained board. Leave it to react for a few minutes. Do not allow the solution to dry, but rinse with lots of clean water. Repeat the process if necessary and rinse with water afterwards.

Note! Do not execute the cleaning process with acetic acid in direct sunlight or on hot surfaces. This might create permanent stains.

Cleaning of neighbouring areas

Windows and glass in particular but also other adjacent areas must be kept clean during the facade

board installation and if necessary protected with plastic film. Alkaline leaching from cement bonded materials (dust from cutting or drilling holes in structural concrete, etc.) is prone to damaging glass and other materials. Therefore, frequent cleaning during and after the construction period is needed.

Surface damages and scratches

Damages and scratches should be avoided by lifting the boards off the pallet and handling them carefully during installation. Scratches might leave white streaks on the surface which will turn dark when exposed to rain, because the board absorbs water through the scratch. In any case the dark area will diminish after 6 to 12 months, because of the carbonation reactions in the cement matrix of the board.

Behaviour in wet conditions

Since the boards are made of Portland cement, their colour may turn darker when exposed to rain if the board absorbs moisture through holes. This is natural behaviour for any cement based product and it does not affect the integrity or long-term durability of the board. The original colour is restored as soon as the boards dry out. The darkening will show after heavy rainfall for the first months after installation. It will gradually reduce within 6 to 12 months, because the cement based matrix reacts with carbon dioxide from the atmosphere – carbonation - and thereby reduces water penetration.

Care & Maintenance

After installation

Annual Inspection

Normally Cembrit facade boards do not require any maintenance. Weathering may however influence the appearance of the facade. Therefore, an annual inspection of the ventilation gaps, joints and fixings is a good idea.

Detection and repair of possible damage ensures a prolonged lifespan for the facade.

Cleaning

Cembrit facade can be cleaned with cold or luke-warm water if necessary with the addition of a mild household cleaning agent not containing solvents. Always start from below with well-defined areas. Rinse with plenty of clean water until the facade is perfectly clean. Before cleaning full scale, it is recommended to test the chosen cleaning method on a smaller area to ensure it works and does not damage the board surface.

High Pressure Cleaning

Warning! High Pressure Cleaning is a severe treatment for fibre cement facade. Exaggerated or wrong use of a high pressure cleaner may damage the surface. Therefore, High Pressure Cleaning is not recommended.

Moss & algae

Moss and algae growth can be removed with common agents available on the market. Care should be taken to ensure that the cleaning agent does not cause damage to the surface of the Cembrit facade boards.

Confirm the compatibility of your cleaning agent with your cleaning agent supplier, and ensure it is applied according to the supplier's instructions. It is advised that before conducting a large scale application a test is carried out on a small, inconspicuous area to ensure that the cleaning agent has no effect on the colour of Cembrit Facade boards.

Efflorescence

Efflorescence is a naturally occurring, white, powdery deposit that can appear on cement-based building materials (including bricks, cement walls, grout, and fibre cement). It is the result of a process in which moisture draws salt crystals to the surface, evaporates, and leaves a chalky substance behind. Efflorescence occurs when all three of the following-conditions exist:

1. Water-soluble salts are present in the building material.
2. There is enough moisture in the wall to turn the salts into a soluble solution.
3. There is a path for the soluble salts to get to the surface.

Efflorescence may also be a sign of water ingress behind the facade. Make certain that all openings are properly covered and there is no water intrusion due to over-driven nails.

While some efflorescence may weather away naturally on its own, it is best to take steps to treat it. Efflorescence can be removed with household white vinegar and water. For most cases of efflorescence, Step 1 - 3 works well. But for substantial deposits of efflorescence go to Step 4.

For best results, follow these cleaning instructions:

1. Protect areas that are not to be cleaned. Rinse all plants and vegetation around the facade with water before and after application of the vinegar.
2. Generously coat the entire surface area with vinegar. Allow the solution to sit on the surface for 10 minutes.
3. Rinse the treated area thoroughly with water from the top down and allow the area to air dry.
4. For extra tough efflorescence:
Use a 10% acetic acid solution and apply to affected area with a cotton cloth. A light scrubbing with the cotton cloth may be required. After about 20 seconds rinse with water.

Health and Safety

As with all building materials, safety precautions must be taken into account and local laws and regulations must be observed.

Cutting and drilling

When cutting, grinding or drilling, dust from the fibre cement boards is released. This dust is characterised as mineral dust. Breathing large amounts of dust may cause irritation to respiratory functions, eyes or skin. Therefore, Cembrit always recommends wearing personal protection equipment or stated by local law (Safety goggles, safety suit and a respiratory mask - P2 marked).

When cutting Cembrit facade boards ensure adequate ventilation.

If the boards are cut indoors, it may be necessary to use an extractor system or a HEPA filter vacuum attachment attached to the power saw. When cutting outdoors, you should also use a HEPA filter vacuum attachment to the power saw. If ventilation is not adequate to limit exposure, wear a disposable respirator or air purifying cartridge respirator fitted with a Class P2 filter (European EN 143 standard). To reduce exposure to dust, Cembrit recommends using Cembrit Circular Blade.

Lifting Cembrit facade boards

When lifting Cembrit facade boards, please consider your lifting methods both in terms of safety but also to avoid damaging the boards.

When lifting or moving the facade board, please make sure to lift the board by its narrow edge as it may otherwise break if handled incorrectly.

If lifting Cembrit facade board manually, make sure to adhere to any local rules. When lifting large boards, use mechanical lifting gear if possible. If this lifting gear uses suction/vacuum, be careful not to apply too much suction, as this may damage the surface or leave permanent marks.

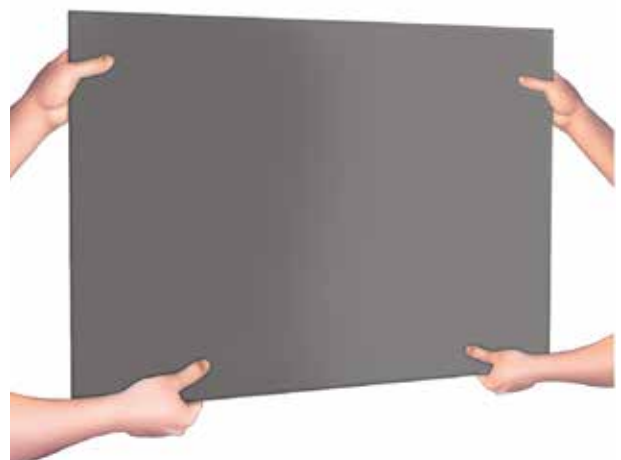
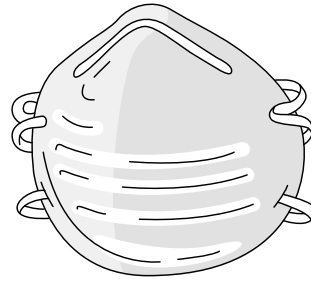

Warranty and disclaimer

Warranty

Warranty conditions are available on request from your local Cembrit office.

Disclaimer

The information contained in this publication and otherwise supplied to users of Cembrit products is based on Cembrit's general experience, best knowledge and belief. However, due to factors which fall beyond Cembrit's knowledge and control, which can affect the use of the products, no warranty is given, express or implied with respect to fitness for particular purpose or otherwise.

Cembrit's policy is one of continuous improvement. Cembrit therefore reserves the right to alter specifications at any time and without notice. Colours and textures may vary according to light and weather conditions. Owing to this and limitations of the printing process, colours in this brochure may vary.

Please, ensure that you have the latest version of this publication by checking that the publication date corresponds with the downloadable version from our website. In case of doubt, please contact your local Cembrit representative.

MARCH 2018

CENBRIT

www.cembrit.com

Please visit the local website for contact details
and further information.

Cembrit is one of the leading European manufacturers of multi-capability fibre-cement building products. Our products and solutions add exciting new design opportunities for moulding attractive, durable settings for people's lives. But Cembrit is more than mere products. We also help make all kinds of design and construction projects easier - as well as more profitable, inspiring and effective. For us, all construction also involves building relations with people, making your day better, and helping you make the day better for others. Making it a day to remember.