

Specification Guide



CELUFORM

LEAVES TREES STANDING

...the specifier's choice of
PVC-UE roofline, windowline
and cladding products

Contents

Roofline

- 3 Benefits of Celuform PVC-UE & PVC-U
- 4 Roofline Range and Colours
- 5 Fascia Installation Details
- 7 Fascia Installation Details
- 8 Bargeboard Installation Details
- 9 Soffit Installation Details
- 10 Roofline Range & Dimensions
- 11 Roofline Range & Dimensions
- 12 Boxed End Installation Details
- 13 Roofline Ventilation
- 14 Roofline Ventilation & Eaves Protection
- 15 Soffit Range
- 16-17 Typical Jointing Details
- 18 Working with Woodgrain Products: Roofline
- 19 Rafter Foot Covers
- 20 Fixing Summary - Roofline

Cladding

- 21 Specifying White Cladding Installations
- 22 White Cladding Installations
- 24 White Cladding Installations
- 26 Cladding Range
- 27 Fixing Summary - Cladding
- 28 Celuex Textured Cladding Installations
- 30 Celutex Cladding Range
- 31 Fixing Summary - Celutex Cladding

Window boards & Trims

- 32 Windowboard & Internal Trims
- 34 Windowboard Range
- 35 Trim Range

Technical

- 36 Frequently Asked Questions
- 37 Product Characteristics
- 38 Product Characteristics
- 39 Fixing Summary - General



Celuform
the UK's first
manufacturer of
PVC-UE building
products



Head Office, Scunthorpe

Benefits of PVC-UE & PVC-U

Celufarm's popularity in the new build, specification, architectural and refurbishment sector stems from its product reliability and wide acceptance amongst the trade and the general public. Refurbishment programmes by housing associations and local authorities acknowledge Celufarm products as the route to lower maintenance costs.

Key Features

Flexibility

A wide range of designs and styles to suit virtually every commercial, industrial and domestic application. With flexibility of application built in at every stage.

Durability

Long-lasting, reliable products that will not rot, split, warp or crack and that are designed to resist the elements.

Practicality

Never needs painting or preserving and will stay looking good for years to come. Easy to specify and simple to install.

Good-looking

A wide variety of colours and finishes to choose from with designs for every application.

Quality - ISO 9001

The company has a Quality Management System approved by the British Standards Institute to ISO 9001 (FM506475).



Environmental - ISO 14001

The company has a Environmental Management System approved by the British Standards Institute to ISO 14001 (EMS 533259).



Responsible Sourcing - BS EN ISO 6001

The company has a Responsible Sourcing System approved by the British Standards Institute to ISO 6001 (BES 581349).



Recovynyl

Recovynyl facilitates the collection and recycling of PVC post-consumer waste from the construction and demolition sector.



Product Guarantees

Celufarm's white products are guaranteed for 20 years and woodgrains for 10 years provided that approved installation and maintenance instructions are followed. Copies of the guarantees which relate to white and foiled products are available from the marketing team on 01724 400487.



Lead Free

Eliminating the lead content in PVC has been a matter of particular concern for responsible manufacturers in our industry. As recommended by the European Commission, UK Government and the PVC industry's Vinyl Plus initiative, some suppliers have already made the switch. Celufarm is among those leading the way. As well as future proofing the product for our customers in case new legislation on material usage does come into play, we are also doing what we can now in the global drive for environmental protection.



Fastrack Cad

Fastrack CAD is an online CAD database which gives architects and specifiers the opportunity to download DXF or DWG files. Celufarm's library of CAD drawings which is available on-line and can be accessed and downloaded by visiting www.celufarm.co.uk



NBS

The National Building Specification (NBS) is a library of clauses that can be selected and edited and used to produce project specifications. Celufarm's NBS information is available on-line and can be accessed through www.thenbs.com



CE Marking

Celufarm PVC-UE cladding is covered by a harmonised European standard - BS EN 13245:2008. A declaration of performance to this standard is available and the product packaging carries a 'CE marking' label.



Roofline Range & Colours

The roof perimeter and eaves are among the most exposed elements of a building. Where traditional timber components have been used, these typically need regular maintenance to prevent deterioration, renew paintwork and preserve appearances. These requirements are inevitably expensive, time-consuming and often disruptive.

CELUFORM makes it possible to eliminate these repetitive tasks. CELUFORM PVC-UE fascia boards, bargeboards and soffit systems provide an attractive and effective, low-maintenance alternative to timber.

VERSATILITY

- **For all building types** Domestic, commercial and industrial - new build or refurbishment
- **Flexible systems** Profiles and accessories adaptable to almost any configuration
- **Pitched and flat roof applications** Fascias and soffits suitable for all roof types

PRACTICALITY

- **Simple installation** Pre-formed trims and corners - requiring minimal cutting
- **Low maintenance** Permanent solutions which never need painting

PERFORMANCE

- **Durable material** Tough, impermeable and resistant to weather and decay
- **Insulating properties** Lower thermal conductivity than timber, concrete and brick (0.06 W/mK)
- **Solving ventilation needs** Systems which satisfy statutory roof ventilation requirements
- **Guarantee** 20 year product guarantee on white products and 10 year on woodgrain available on request

VISUAL APPEAL

- **Enhanced appearance** Clean sight lines, good detailing, and neat joints

The CELUFORM range of PVC-UE fascia and bargeboard systems provides a full range to suit all applications:

- **Appearance:** plain-faced - or with decorative features - square or bull-nosed profiles
- **Colour choice** (*subject to product range*): (see Colours/Ordering) Warm White, Ice White, Mahogany, Golden Oak, Ebony
- **Widths:** ranging from 150mm to 405mm (600mm in the DLR fascia capping range)
- **Profile:** including - to accept horizontal or inclined. Soffits - flat-backed options for ease of installation

A comprehensive selection of corners, end caps and joint trims ensures neat and complete finishing.

All profiles illustrated can be used in fascia or bargeboard configuration, providing a fully compatible finish around the roofline. Boards are supplied in 5-metre lengths as standard.

Profile options include:

ELITE

- 25mm bull-nosed flat-backed board
- Allows direct fixing of rainwater systems (without needing timber support)

ELITE GROOVED

- 25mm bull-nosed, 22mm thick flat-backed board
- Allows direct fixing of rainwater systems
- Groove will accept horizontal or inclined soffit boards

BULLNOSE FASCIA

- 16mm flat-backed board with 25mm bull-nose to support soffit board
- Co-extruded PVC-U skin on front and rear surfaces allows direct fixing of rainwater systems

CONQUEST

- 19mm square-edged board with fixed groove and return leg
- Allows direct fixing of rainwater systems
- Groove will accept horizontal or inclined soffit boards

VANQUISH

- 16mm square-edged board with fixed groove and return leg
- Allows direct fixing of rainwater systems (without needing timber support)
- Groove will accept horizontal or inclined soffit boards

EMPEROR

- 16mm flush square-edged board with fixed groove
- Allows direct fixing of rainwater systems
- Groove will accept horizontal or inclined soffit boards

DLR

- 9mm square-edged board with fixed groove and return leg
- Requires a new timber sub-fascia when used as a fascia board
- Can be used as cost effective bargeboard in conjunction with both CONQUEST and VANQUISH ranges

CONQUEST TORUS

- 18mm ogee board with fixed groove and return leg
- Allows direct fixing of rainwater systems

ESPRIT

- 10mm board with rounded edge and square ended leg
- Requires sub-fascia to support and fix rainwater system
- Widths from 150mm to 400mm
- Available with Celutex™ woodgrain effect



Fascia Installation Details



This section of the guide is intended to provide you with a brief overview of the popular products in Celuforn's Roofline range, where they can be used and the main criteria for installation.

Pre-Installation Considerations

Preparation:

- All access and works to comply with current and relevant Health & Safety and Construction Design Management Regulation recommendations
- Clear work area in-line with best practice before starting work, ensuring safe scaffolding access is available
- Remove first row of roof tiles where necessary
- Remove all existing fascia / soffit materials
- Replace any un-sound / rotten timber or felt and treat rafter ends with preservative
- Maintain air path for roof ventilation

Installation considerations

Installation considerations are intended to provide you with need-to-know information for the core processes of product installation.

They are not intended as an exhaustive installation guide. The information presented will provide you with a valuable resource when assessing how best to use our products in your selected application.

Fascia

Fit directly to rafter ends using polytop nails, 2 per fixing centre max 600mm centres - 65mm nails. Austenitic stainless steel (Grade A4 BS6105). Fascia is capable of load bearing in relation to light weight gutters and the first row of roof tiles (Eaves Tiles).

Expansion gaps of 5mm per board end must be allowed for during installation.

Cover joints and Corners to be secured using low modulus neutral cure silicone. BS5889 Type A.

Gutter brackets to be secured directly into the board using stainless steel screws - 10 gauge x 25mm long (parallel thread form).

All Celuforn fascia boards 16mm and over are capable of load bearing and may be used in new-build or refurbishment.

Typical Eaves Details

VAN Fascia & 9mm Vented Soffit

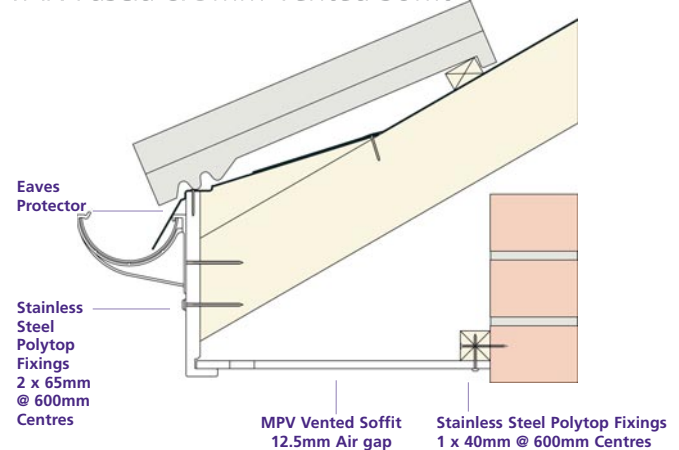

ELG Fascia & 9mm Vented Soffit

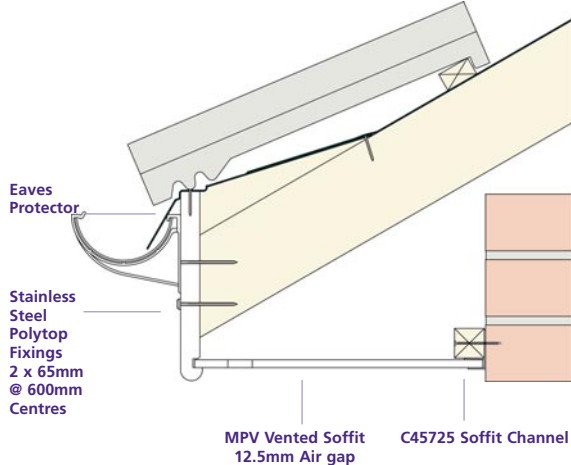

C5360 Fascia & 9mm Vented Soffit

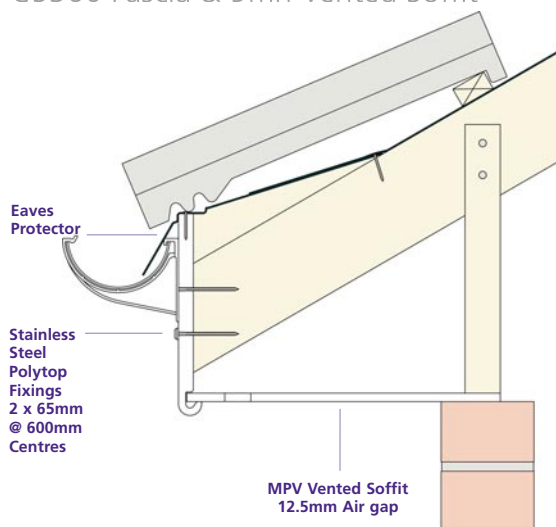

For finish options please see Current Price List.

Fascia Installation Details

CTOR Fascia & 100mm V-Joint Cladding - Vented

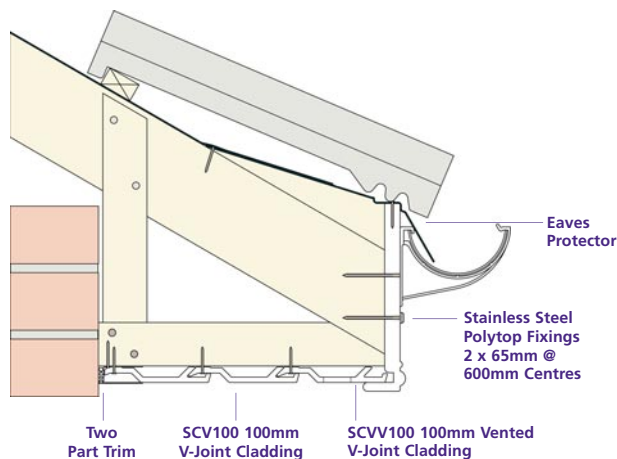

Tongue and Groove Cladding

Shiplap and Open-V cladding planks may also be used as soffit. The Open-V version is also available in a pre-ventilated form. Vented cladding planks have a 12.5mm air gap which permit 25mm continuous ventilation to be achieved via the use of two rows of vented product. Cladding planks are secured using 30mm cladding pins.

- Joints for ELG, VAN, C5360 & DLR are available in 600mm lengths in addition to shorter standard lengths.
- When using CTOR as a bargeboard the box end piece will need to be packed out to prevent the Ogee form of the bargeboard-standing proud of the box end piece.

VAN & MPV Timber Frame Detail

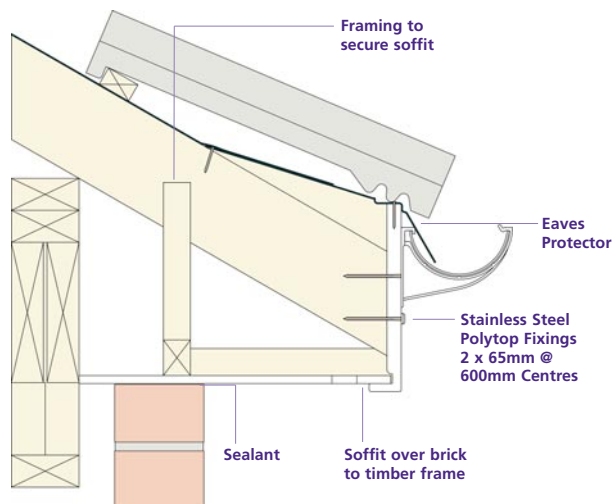

Timber Frame

When fitting to timber frame project, be aware the soffit needs to be large enough to carry over the top of the brickwork line, back to the timber frame. Soffit widths should not exceed 300mm without additional support.

Extreme Winter Fitting Guidelines

- A continuous tilting fillet must be used.
- The fillet provides screw retention for the gutter brackets and support to the top of the fascia. It should be securely nailed into the top of each rafter
- Plastic headed, 65mm long, austenitic stainless steel (grade A4) nails, are used to fix the fascia by nailing directly into rafter ends.
- 2 fixings must be used at each fixing centre, with a maximum distance of 600mm between centres.
- Fixings should utilise as much of the height of the rafter end as possible, taking care not to split the timber and ensuring full depth nail engagement.
- Gutter bracket screws should be fixed through the PVC-UE fascia into the continuous tilting fillet.
- Gutter specification and fixings should be obtained from the gutter system manufacturer.

VAN & MPV Fascia Detail for Extreme Winters

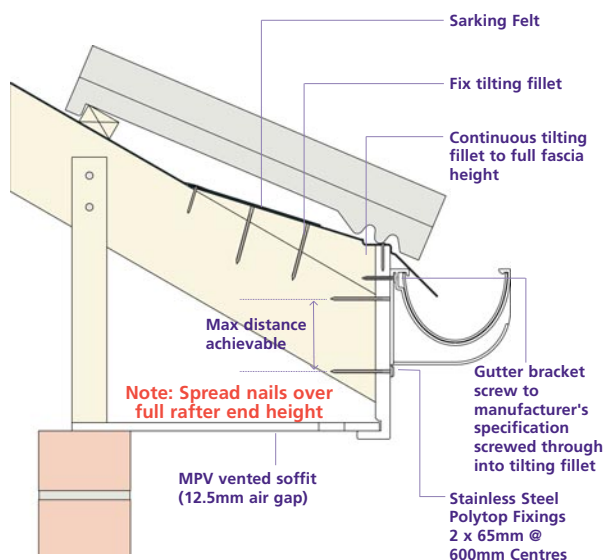

When considering the overall performance of the eaves area of a roof, it is important to include the roof design, the components and ultimately the imparted load from rain, snow and wind. The above guidance has been compiled to aid the roof designer in obtaining the maximum performance from the PVC-UE fascia element.

Fascia Installation Details

Flat Roof Installation

When fitting to a flat roof area, consideration must be given to allow adequate ventilation above the insulation in order to comply with building regulations. See ventilation section for a full explanation of ventilation requirements.

Flat Roof Detail

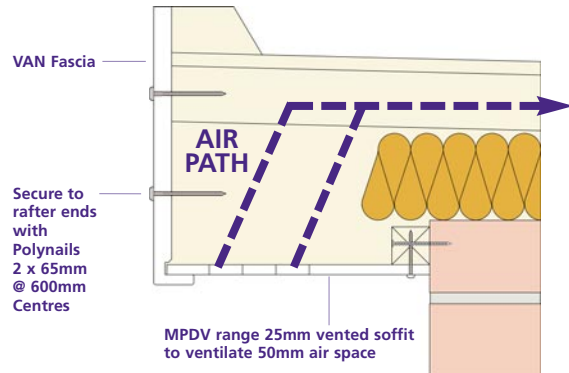

Replacement Projects

Celuform manufacture several designs of fascia capping boards which can be fitted over the top of existing timber fascias and bargeboards provided these are sound.

Any unsound or insecure timbers or rafter surfaces should be removed and replaced before overcapping.

Fascia capping boards are available in square, bullnose and ogee designs and fit flush to the existing sound fascias or backing boards.

Fascia capping boards also incorporate a return leg to cover the existing fascia and enclose the soffit leaving a neat finish.

All overcapping fascias can also be used for new-build work, but will require a minimum 12mm marine plywood backing board. (see Fixing Summary).

DLR Fascia & 9mm Vented Soffit

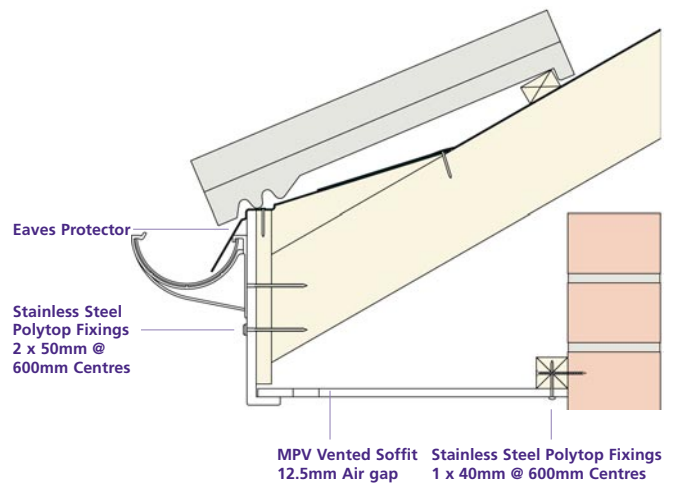

VAN Fascia & 9mm Inclined Soffit

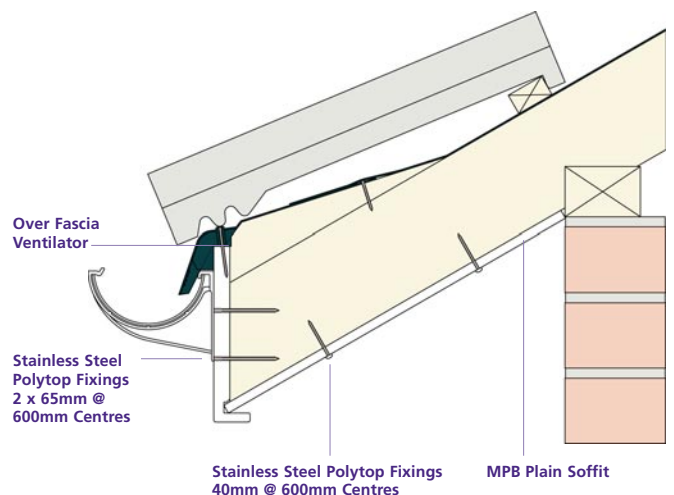

Inclined soffits

In both new-build and replacement situations, VAN or DLR fascias can be used in conjunction with inclined soffit details, as the return leg (36mm) is wide enough to provide support for the soffit board.

Soffits in this situation are normally plain, such as MPB, but can be detailed with cladding if desired.

In this instance, the use of over fascia ventilation is recommended as the ventilation slots in pre-ventilated soffits are restricted. Alternatively a soffit with increased ventilation can be selected.

The boards should be fixed to the rafters at not greater than 300mm centres across the soffit width.

For finish options please see Current Price List.

Bargeboard Installation Details

Typical Verge Details

VAN - 16mm Bargeboard & Plain Soffit

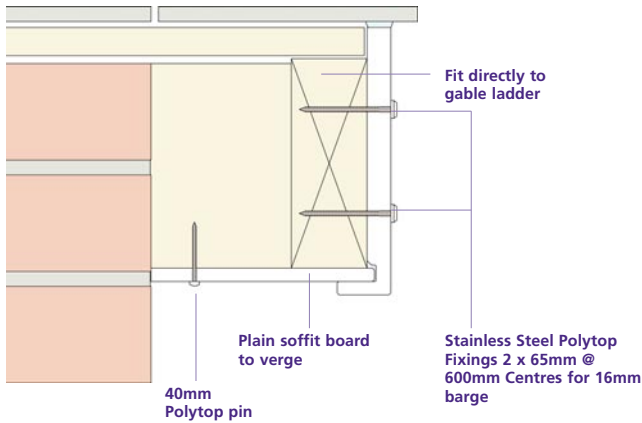

DLR - 9mm Bargeboard & No Soffit

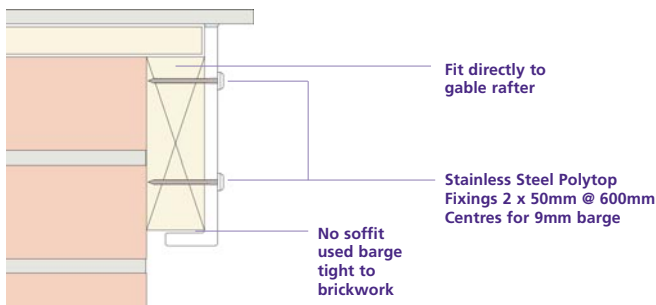

TRS - 8mm Bargeboard to Timber Frame

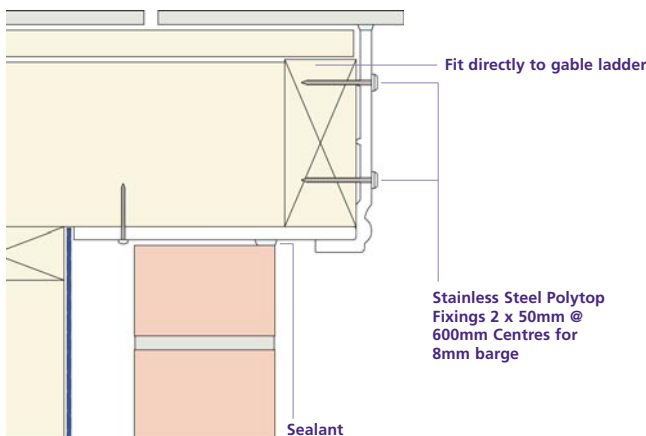

Bargeboard

VAN 16mm bargeboard should be installed using 65mm Polytop nails 2 per fixing centre at maximum 600mm centres. Austenitic stainless steel (grade A4 BS6105).

DLR 9mm bargeboard should be installed using 50mm Polytop nails 2 per fixing centre at maximum 600mm centres. Austenitic stainless steel (grade A4 BS6105).

Boards less than 16mm thick boards are required to be fully supported along their length.

The joint of bargeboards meeting at a ridge should be covered using a cover joint or feature finial and secured using Low Modulus Neutral Cure Silicone

Complementary Ranges

The VAN and DLR are complementary ranges being the same external shape.

This allows the 9mm barge to be used in conjunction with the 16mm fascia for a more cost effective solution.

The ELG and C5360 are also complementary ranges being the same external shape.

This allows the 16mm barge to be used in conjunction with the 22mm fascia, to be a more cost effective solution.

NB: C5360 barge can be run into a ELG box end piece to create a stepped box end feature.

Soffit Boards

Soffit

Celuform soffit boards are available in non-vented versions for use as verge soffit or as eaves soffit when other forms of eaves ventilation are to be used. They are also available in ventilated form and can contribute towards providing the necessary roof space ventilation.

- Soffit is secured at maximum 600mm centres to timber using 40mm Polytop pins, alternatively a wall side fix may be achieved using a Soffit Channel.
- In properties where the outer skin of brickwork is level with the bottom of the fascia board soffit groove, the soffit may be extended over the brickwork and clamped using timber battens secured to the rafter sides.
- Soffit widths should not exceed 300mm without additional support.
- H-section trim is used to join soffit boards.
- A soffit board channel (F trim or J trim) can be used to securely locate the soffit at the wall.
- Soffits can be detailed from standard soffit boards, or Open 'V'-Joint/Shiplap cladding.
- All Open 'V'-Joint and Shiplap cladded soffits should be fully supported and fixed to timber bearers at max 600mm centres along the soffit length
- It is recommended that cladding is detailed when designing extra wide soffits.
- The appropriate trims must be used in conjunction with cladded soffits (see Cladding section).

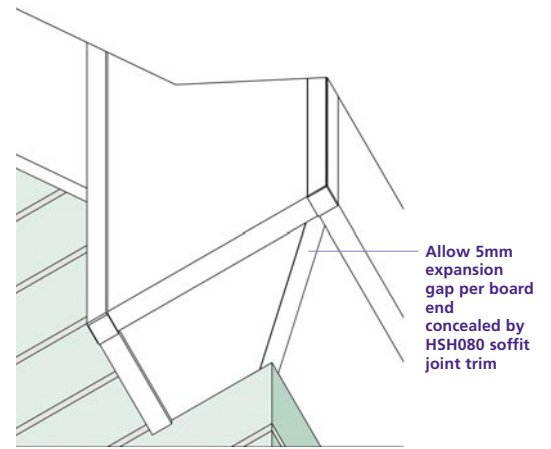

Stainless Steel Polytop Fixings
1 x 40mm @ 600mm Centres

Installation

Use Stainless Steel Polytop Fixings 1 x 40mm @ 600mm Centres. Soffit widths should not exceed 300mm without additional support and fixing.

Mitred Soffit Corner

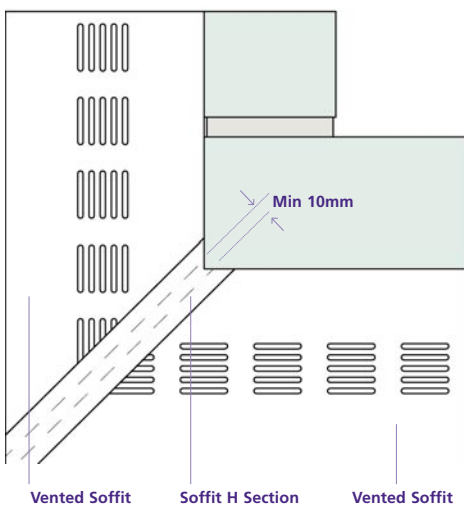

Straight Soffit Corner

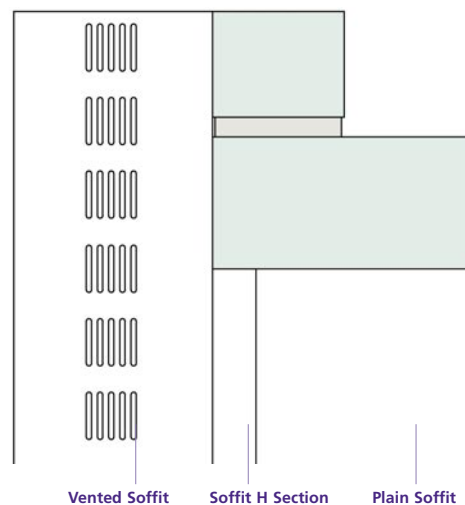

Roofline Range

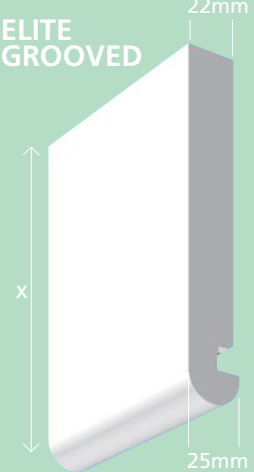
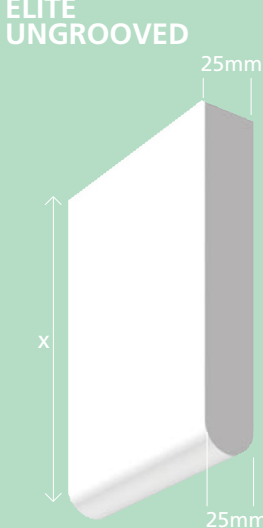
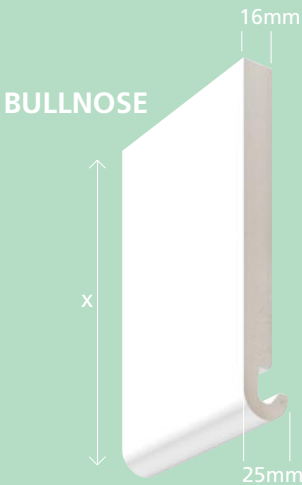
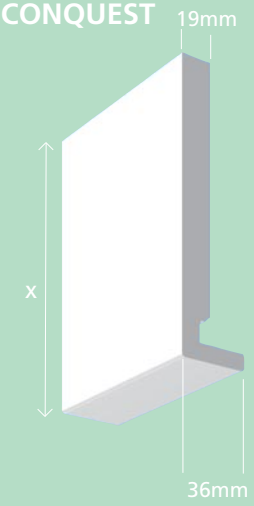
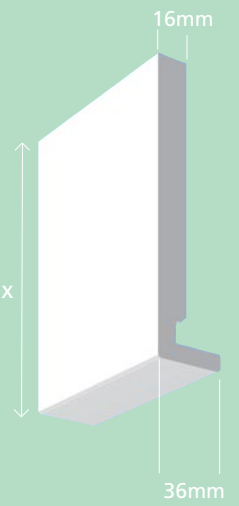
		Code	Dimension X
 <p>ELITE GROOVED</p>	 <p>ELITE UNGROOVED</p>	ELG ELG150	150mm
		ELG175	175mm
		ELG200	200mm
		ELG225	225mm
		ELG250	250mm
		ELG300	300mm
		ELG405	405mm Double Nose
		ELG405BOX	405mm Double Nose (1.25)
		ELU ELU150	150mm
		ELU175	175mm
		ELU200	200mm
		ELU225	225mm
		ELU250	250mm
		ELG300	300mm
		ELU405	405mm Double Leg
 <p>BULLNOSE</p>	C5360 C5360150	150mm	
	C5360175	175mm	
	C5360200	200mm	
	C5360225	225mm	
	C5360250	250mm	
	C5360405	405mm Double Leg	
	C5368405	405mm Double Nose (1.25m)	
			L5019 L5019150
		L5019175	175mm
		L5019200	200mm
		L5019225	225mm
		L5019250	250mm
		L5019405	405mm Double Leg
		L5019405125	405mm Double Leg (1.25m)
 <p>CONQUEST</p>	 <p>VANQUISH</p>	VAN VAN150	150mm
		VAN175	175mm
		VAN200	200mm
		VAN225	225mm
		VAN250	250mm
		VAN355	355mm Double Leg
		VAN405	405mm Double Leg
		VAN405BOX	405mm Double Leg (1.25m)

Roofline Range

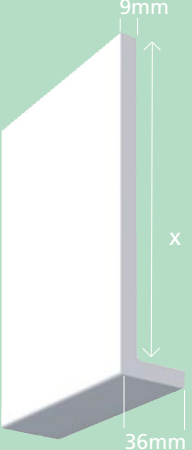
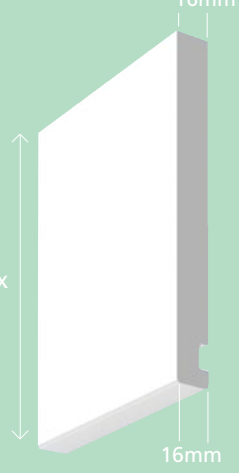
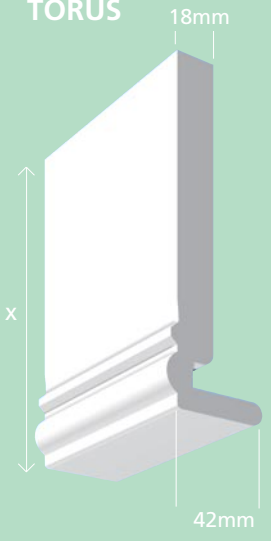
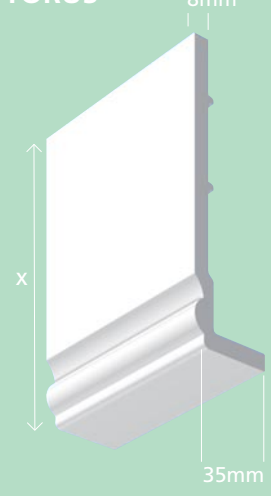
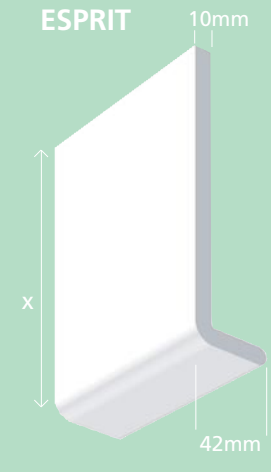
		Code	Dimension X							
DUOLINER 	DLR*	DLR100 DLR125 DLR150 DLR175 DLR200 DLR225 DLR250 DLR300 DLR400 DLR400 DLR500 DLR550 DLR600	100mm 125mm 150mm 175mm 200mm 225mm 250mm 300mm 405mm 450mm Single Leg (1.25m) 500mm 550mm 610mm							
	EMPEROR 	EMP	EMP150 EMP175 EMP200 EMP225 EMP250 EMP405 EMP405BOX	150mm 175mm 200mm 225mm 250mm 405mm Double Leg 405mm Double Leg (1.25m)						
			CONQUEST TORUS 	CTOR	CTOR150 CTOR175 CTOR200 CTOR225 CTOR250 CTOR405	150mm 175mm 200mm 225mm 250mm 405mm Double Leg				
					TORUS 	TRS*	TRS150 TRS175 TRS200 TRS225 TRS250 TRS300 TRS405	150mm 175mm 200mm 225mm 250mm 300mm 405mm Double Leg		
							ESPRIT 	ESP*	ESP110 ESP160 ESP185 ESP210 ESP235 ESP260 ESP310 ESP400 ESP454	110mm 160mm 185mm 210mm 235mm 260mm 310mm 400mm 454mm Double Leg

*These products can be used as fascia boards with a minimum 12mm marine ply backing board

Box End Installations

Boxed Ends

To provide a neat and weathertight area at the point where Fascia and Bargeboard meet, it is necessary to construct a box end.

A box end piece is cut from wide Bargeboard material (nominally 405mm) to suit the roof pitch and overhang requirement. When using DLR bargeboard large box end details may be obtained by using the extra wide product of 600mm width.

The soffit forming the base of the box end must match the eaves soffit and is mitred at the joint, using H-section as a jointing trim.

Box ends are supported using a preservative treated timber framework.

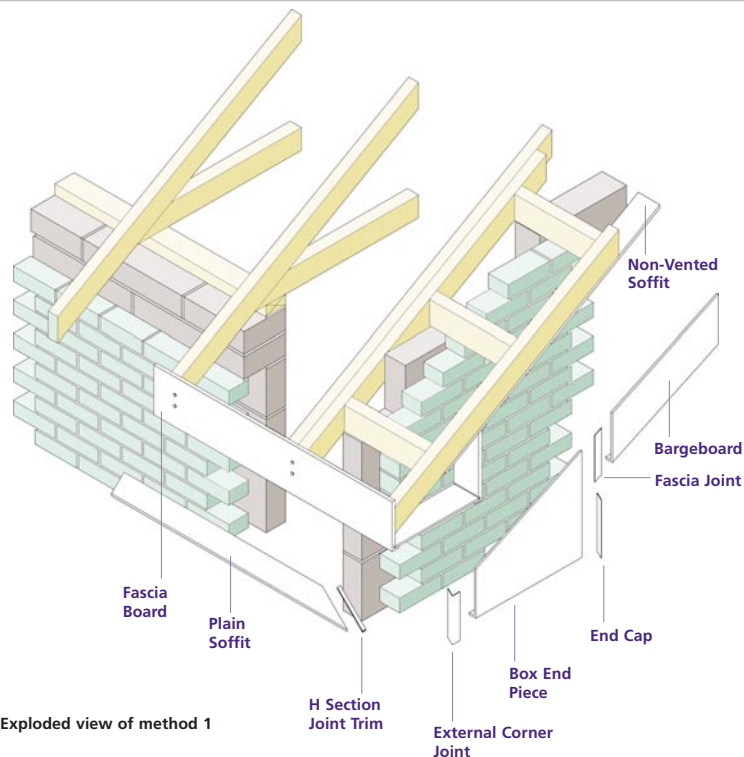

Boxed End Methods

The jointing of the bargeboard into the box end piece can be achieved in two ways.

Method 1

The bargeboard is cut plumb directly above the back edge of the box. A fascia joint with a piece removed is then used to cover the vertical joint. The exposed rear corner is then covered using the relevant end cap.

Method 1

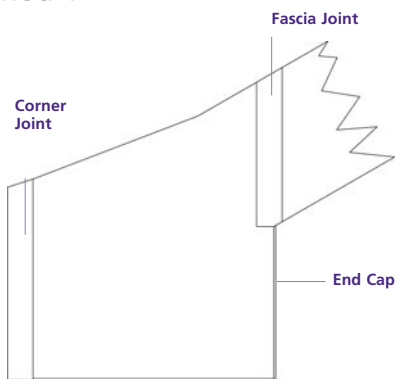

Method 2

The bargeboard is cut plumb directly above the back edge of the box. A corner joint with a piece of one face removed is then used to cover the back corner and bargeboard-box end piece joint.

Method 2

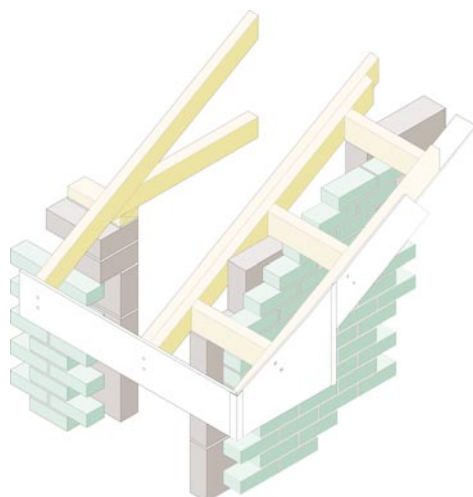
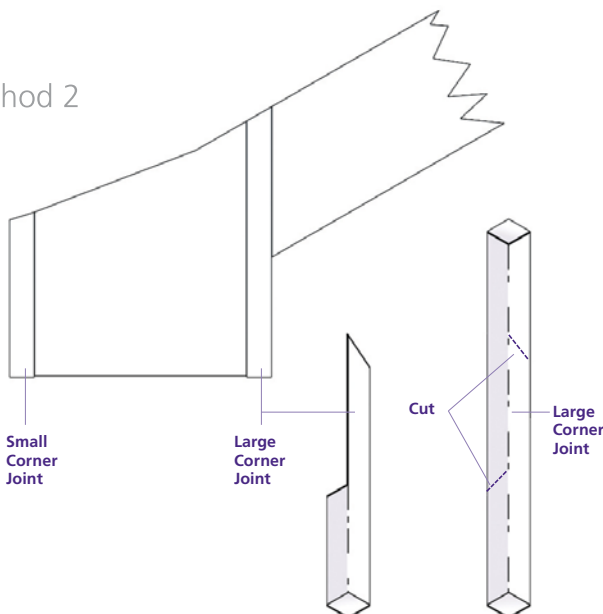

*Unexploded view of method 1

Roofline Ventilation

The requirement to ventilate the roof space of a building to protect the building and people who use it from the harmful effects caused by condensation is covered by 'The Building Regulations 2000.'

Guidance on the provision of adequate ventilation is given in Approved Document C2 Resistance to Moisture (2004 edition) and detailed in BS5250: 2011 Code of practice for control of condensation in buildings.

Celuform provides a comprehensive range of products designed to comply with the requirements of these regulations.

Celuform 9mm soffit boards are available in non-vented versions for use as verge soffit or as eaves soffit when other forms of eaves ventilation are to be used.

They are also available in ventilated form and will contribute towards providing the necessary roof space ventilation.

These pre-ventilated soffits are available in 12.5mm air gap up to 600mm wide and 25mm air gap up to 425mm wide.

All soffits are covered by Celuform's British Board of Agreement Certificate No. 11/4835.

Provision of Ventilation

The illustrations opposite reflect the basic ventilation requirements normally applicable for impermeable underlays (Type HR). For additional information including the use of vapour permeable underlays (Type LR) please refer to BS5250: 2011.

Strip Ventilators

Celuform also provides a continuous ventilator strip for eaves ventilation.

This strip is manufactured from PVC-U in 5m lengths giving ventilation equivalent to a 25mm air gap.

Provision of Ventilation

Cold Roofs

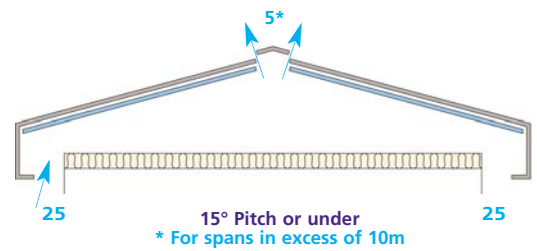
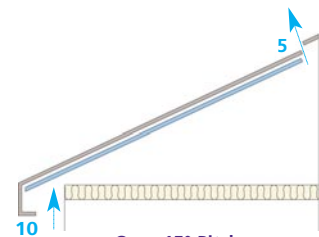
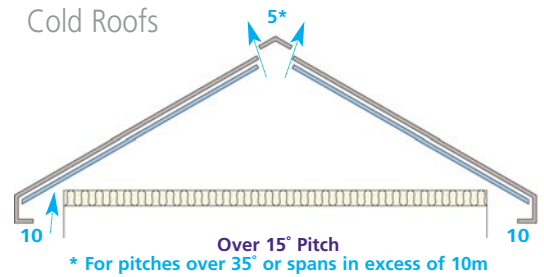

Warm Roofs

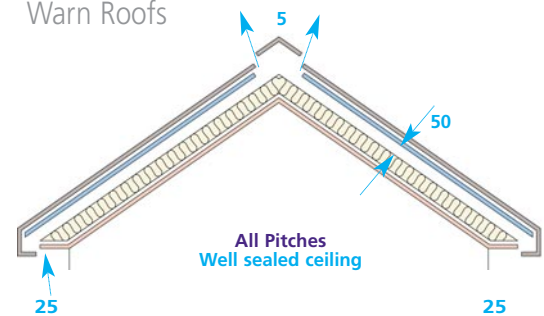

Dimensions in millimetres.

Ventilation Products

MPV

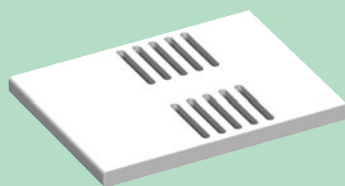

12.5mm Air Gap

MPDV

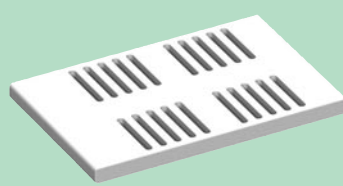

25mm Air Gap

C57975

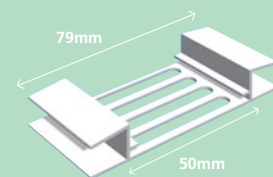

Equivalent 25mm Air Gap

Roofline Ventilation

Ventilation and Eaves Protection

C5530EPS Eaves Protector

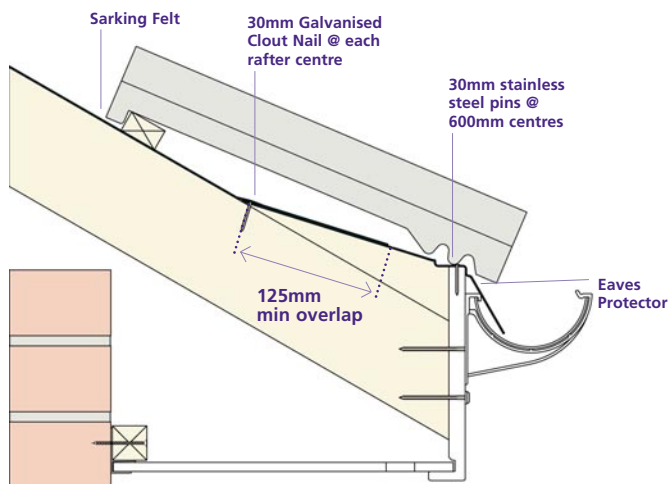

Eaves Protection

The Celufarm Eaves Protector C5530EPS has been designed to provide a long-term solution to the problems associated with eaves decay under the roof, including the degradation of sarking felt and the secondary rotting of rafter timbers and other roof structures.

Available in 2.5m lengths the Celufarm eaves protection profile consists of a durable black pigmented PVC-U profile located between the roof tiles and the PVC-UE fascia system.

Whether used on refurbishment projects or in new-build installations, the traditional sarking felt finishes before the fascia and is lapped over the eaves protector. Therefore it is not exposed to the elements and is not subject to decay.

Ventilation and Eaves Protection

A further enhancement of the idea of the eaves protector comes in the form of UNIOFV an eaves protector combined with over fascia ventilation and bird comb. The ventilation of the roof void at eaves level is provided by an upstand on the underside of the eaves protector which sits on the top edge of the fascia board.

The UNIOFV product provides ventilation equivalent to a 10mm continuous slot.

The provision of an integral bird comb provides an effective barrier against bird infiltration into the roof void when using profiled roof tiles. If flat slate tiles are to be used the comb is readily removed.

The durability and rigidity of the eaves protectors and the load bearing features of Celufarm fascia boards are such that no tilting fillet is needed.

UNIOFV Over Fascia Ventilator & Eaves Protector

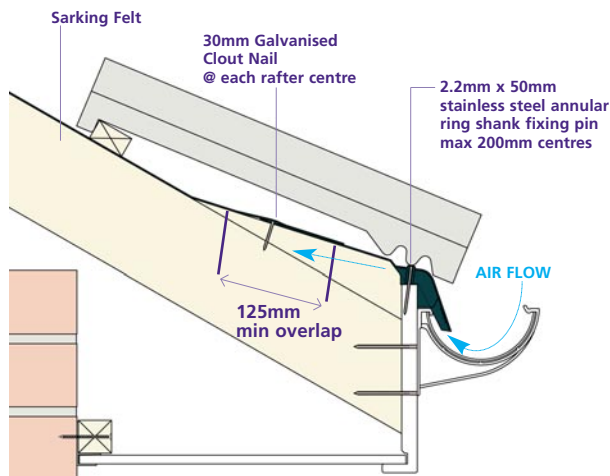

C5540250FV Over Fascia Ventilation Strips

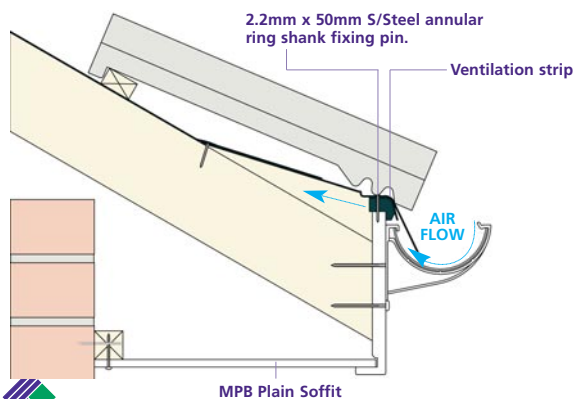

Eaves Ventilation

A simple means of providing ventilation over the fascia is also available in the form of Celufarm over fascia ventilation strips.

This product is available as C555601225 to provide ventilation equivalent to a 10mm continuous slot and as C5540250FV to provide ventilation equivalent to a 25mm continuous slot.

As with the UNIOFV, this product is designed to sit directly on top of the fascia board. Fix with 2.2mm x 50mm stainless steel annular ring shank fixing pin at every fixing centre.

Soffit Range

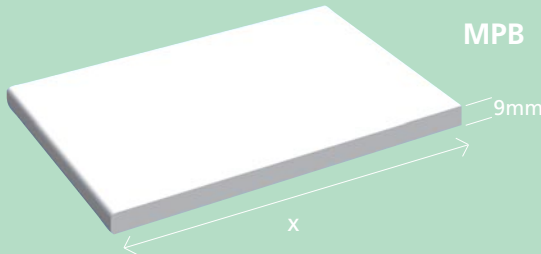
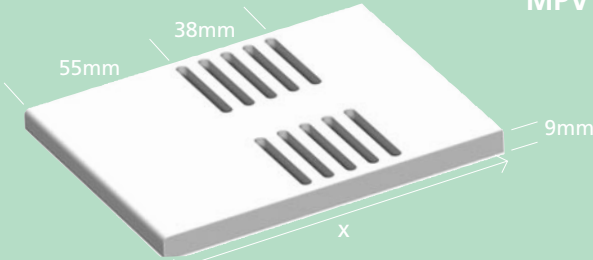
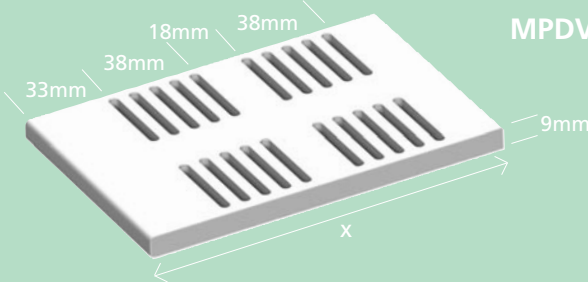
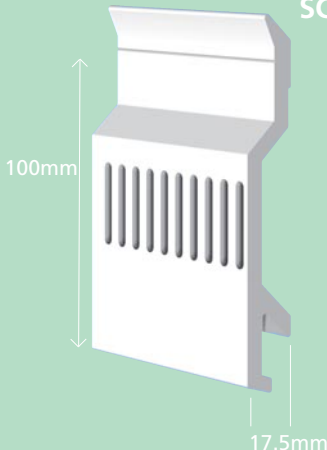
		Code	Dimension X
<p>Non-ventilated Soffit</p>  <p>MPB</p>		<p>MPB</p> <p>MPB100 MPB125 MPB150 MPB175 MPB200 MPB225 MPB250 MPB275 MPB300 MPB325 MPB400 MPB425 MPB500 MPB550 MPB600</p>	<p>100mm 125mm 150mm 175mm 200mm 225mm 250mm 275mm 300mm 325mm 400mm 425mm 500mm 550mm 600mm</p>
<p>12.5mm Air Gap Pre-Ventilated Soffit</p>  <p>MPV</p>		<p>MPV</p> <p>MPV100 MPV150 MPV175 MPV200 MPV225 MPV250 MPV300 MPV325 MPV375 MPV400 MPV425 MPV600</p>	<p>100mm 150mm 175mm 200mm 225mm 250mm 300mm 325mm 375mm 400mm 425mm 600mm</p>
<p>25mm Air Gap Pre-Ventilated Soffit</p>  <p>MPDV</p>		<p>MPDV</p> <p>MPDV200 MPDV225 MPDV275 MPDV300 MPDV325 MPDV375 MPDV425</p>	<p>200mm 225mm 275mm 300mm 325mm 375mm 425mm</p>
<p>12.5mm Air Gap Pre-Ventilated Cladding</p>  <p>SCVV100</p>		<p>Cladding</p> <p>Code SCVV100</p>	<p>Coverage 100mm</p>

Typical Jointing Details

Soffit Joint Installation

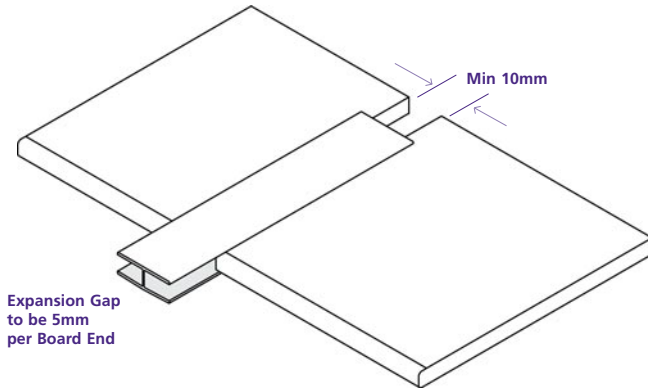

Jointing of Fascia & Bargeboard

All Celuform fascia board ranges have a series of specifically designed accessories to complement the size and shape of the fascia board.

These include some of the following:

- Extra Large Corner Joints (Typically 600mm for Box ends)
- Standard Corner Joints
- Fascia Joints
- Internal Corner Joints
- End Caps

All joints should be secured using Low Modulus Neutral Cure Silicone.

Gaps to increase to 8mm per board end for foiled products

Fascia Joint Installation

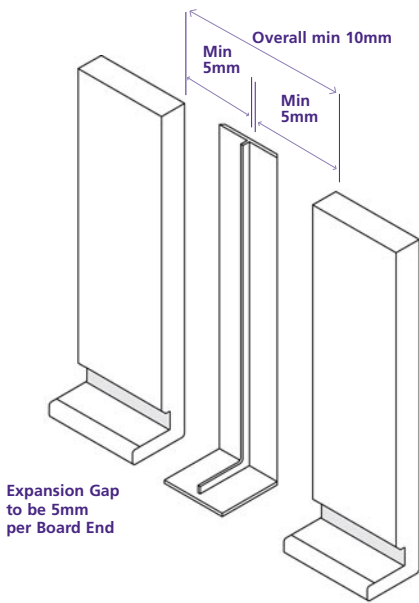

Corner Joint Installation

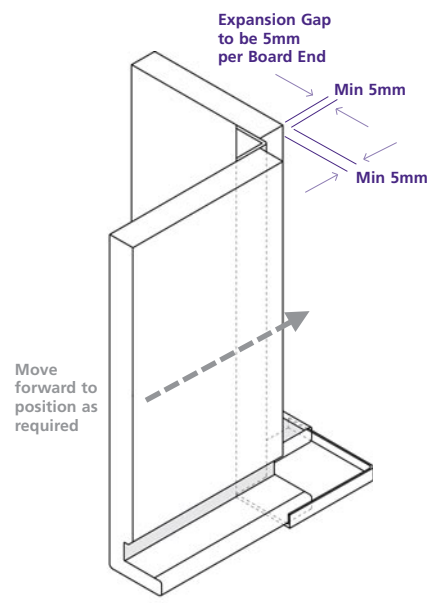
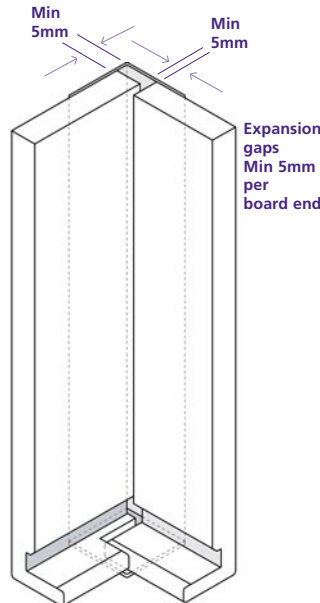

Butt Joint - Plan View

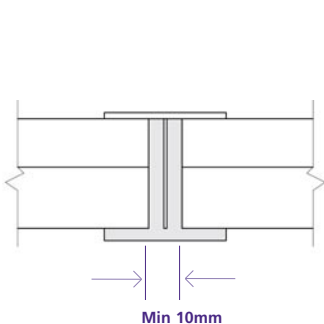

Corner Joint - Plan View

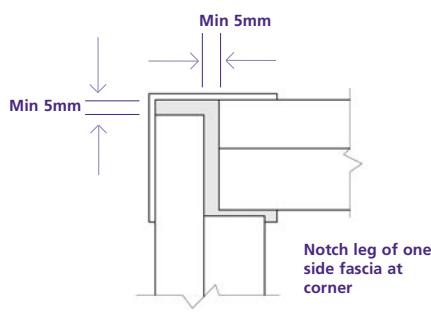

Internal Joint Plan View

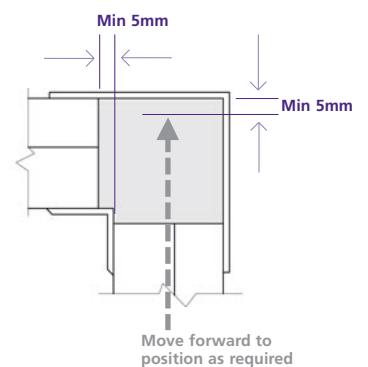

Typical Jointing Details

Apex Joint

Apex joints are made utilising a standard fascia joint from the main fascia range cut to suit. e.g. for the VANQUISH range, item CSQ JNT.

Alternatively, a decorative finial can be used to give a more aesthetically pleasing finish.

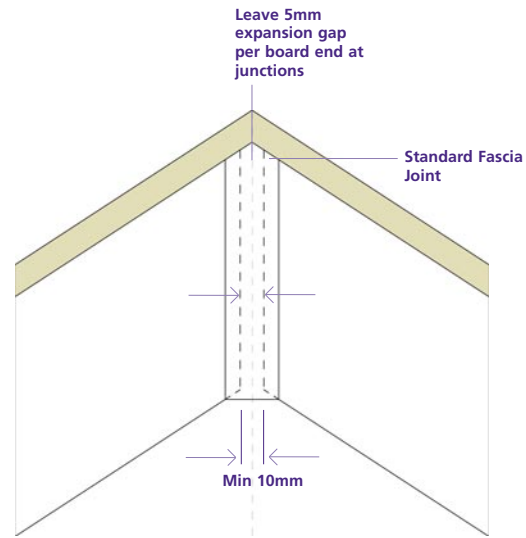
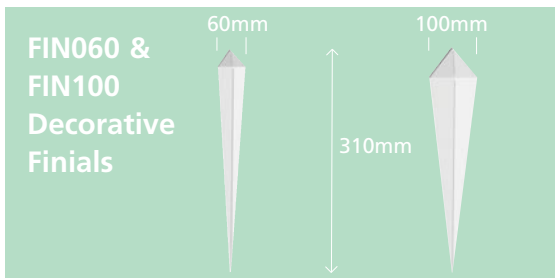

Method 1

Method 2

Running Gables / In-Line Pikes

Where fascia meets barge along a running gable, it is important that the same range of fascia and bargeboard is used. This will prevent a step being created.

Four typical methods are shown to the right. The exact method used will be dependent on roof pitch, layout etc.

In-Line Pike Junctions

- In-line pike junctions can be created using standard joints from the relevant ranges.
- Joints and bargeboards will need cutting to suit.
- Fascia and bargeboard material will need to be the same type.

In-Line Box End Options

In-line boxends can be created using the same construction methods as shown previously.

It is important that the same material is used on the barge as is used on the fascia.

This configuration is often used to a side gable where the gable meets a roof projection.

Fascia and bargeboard material will need to be the same type.

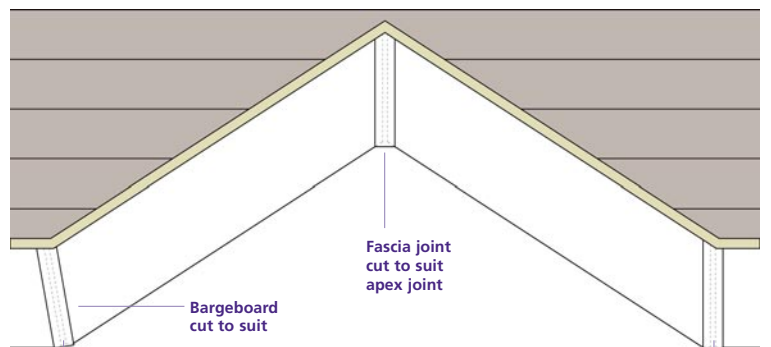

Method 3

Method 4

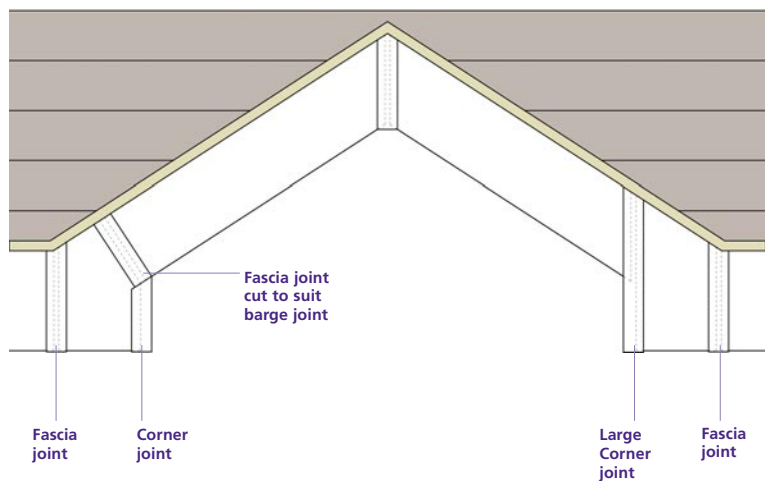

Working with Woodgrain Products - Roofline

Working with Woodgrain products requires slightly modified procedures and installation processes. Overall, woodgrain products are as easy and convenient to fit and use as most other products in the Celuform range. However, with a little extra knowledge and care at the preparation stage, you can save yourself potential difficulties later on.

Celuform's Woodgrain foiled profiles have been extensively tested to ensure long term weatherability and are guaranteed for use both internally and externally for a period of 10 years. However, non-white systems have a different potential for heat absorption, with resultant risk of excessive expansion and contraction. In particular, with a Woodgrain foiled coating, this heat absorption can be significant, with potentially detrimental effects on long term installation. Special consideration needs to be given when installing Woodgrain products to minimise the amount of heat build up and provide for greater amounts of expansion.

The following additional fixing details must be followed when installing Woodgrain products:

Fascias/Bargeboard

1. Increase expansion gap from 5mm for white to 8mm.
2. All installations to take place at ambient temperatures - between 5°C and 25°C.
3. All pre-installed products to be kept away from direct sunlight, preferably indoors, at all times.
4. All joints to be made with Woodgrain corners and butt joints.

Foiled Fascia Joint Installation Details

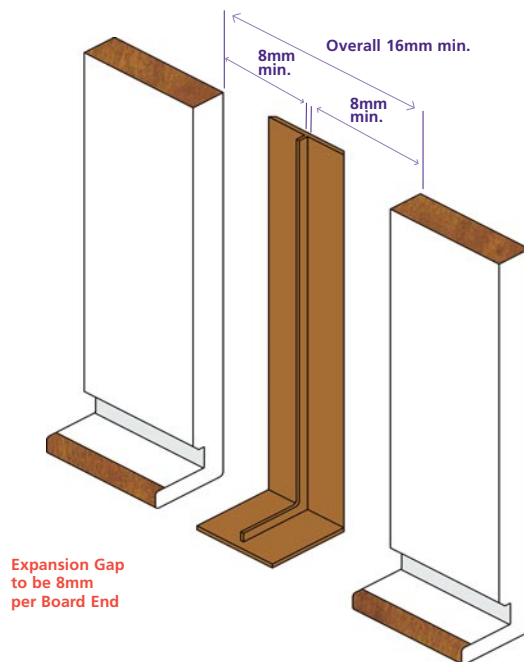

Foiled Soffit Joint Installation Details

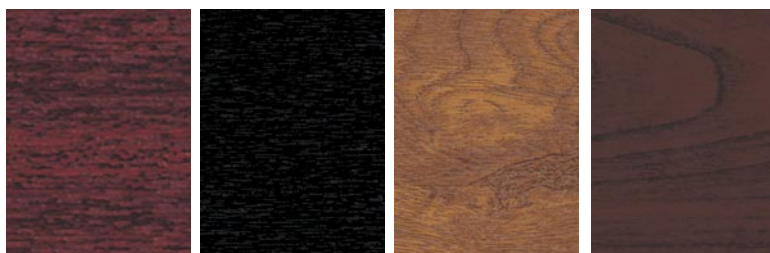
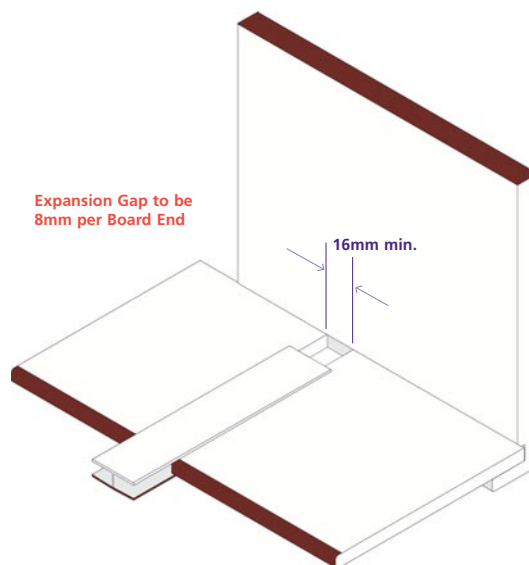

Mahogany

Ebony

Golden Oak

Piedmont

Rafter Foot Cover



Where the roof design incorporates exposed rafter feet Celuforn offers the ability to extend the low maintenance characteristics of our roofline products to these features which are susceptible to weathering. In addition the components are coloured warm white to match our most popular roofline profiles providing a coherent finished appearance.

RAFTER FOOT COVER PACK

Three part maintenance free PVC- U packs incorporating flat hinged sleeves, end caps and joint trims. Sleeves and caps are fixed to the sides and front of the exposed feet protecting them from weathering. A 4mm slot is incorporated during installation to allow moisture to escape. The joint trim is used for rafters with a thickness above 35mm.

Components are supplied in convenient single dwelling packs. Use of rafter foot covers avoids the need to prime undercoat and top coat exposed rafters on new build projects.

Installation

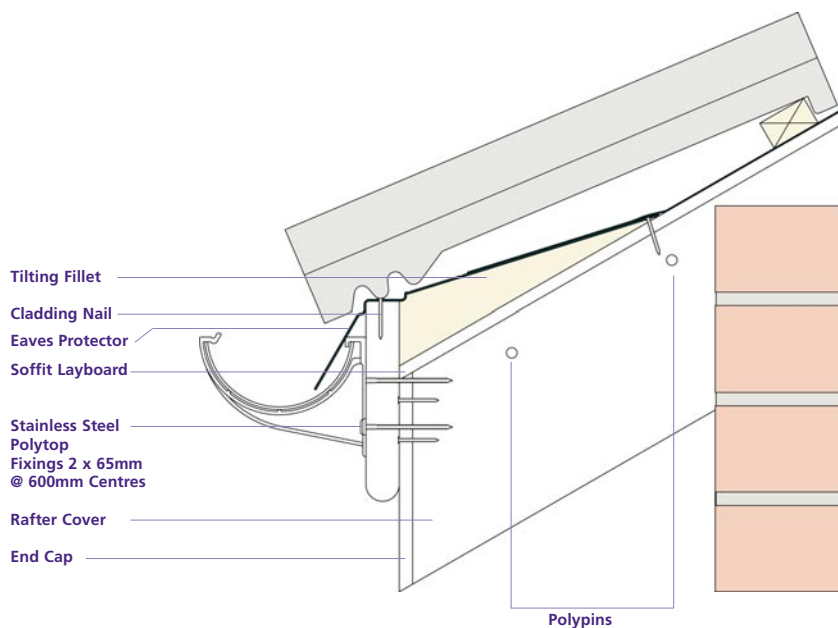

RAFTER FOOT COVER PACK

3 part pack containing: 10 x Hinged Cover
1 x Joint Trim
5 x End Cap

Code

RAFTFTCOVER

Hinged Cover

(supplied flat)

Finish:White

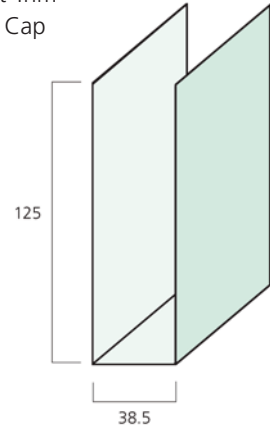

Joint trim

Finish: White

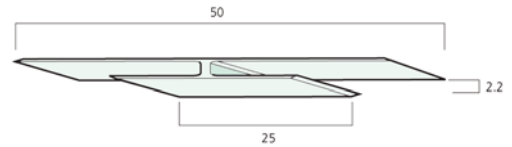

End cap

Finish: White

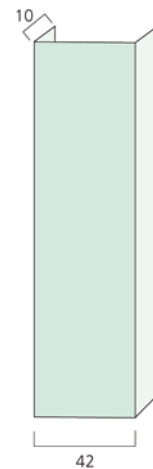

Fixing Summary - Roofline

Fascia (thickness)	Fixing detail	Fixing type	Product ref.
8 - 10mm Fascia Capping	Detail with marine/ WBP plywood backing board (12mm min)	50mm Polytop Nails 50mm Polytop Screws	SS-50N
16mm - 25mm Fascias	Full replacement	65mm Polytop Nails 65mm Polytop Screws 50mm Polytop Screws	SS-65N SS-65S
Soffit	Fixing detail	Fixing type	Product ref.
9mm Soffit	Soffit bearers recommended	40mm Polypins	SS-40P
Cladding boards used as Soffit	Fixing detail	Fixing type	Product ref.
100mm Open V Joint 150mm Sniplap Cladding	Timber soffit bearers	30mm Cladding Nails or Pin	SS-30-CN or SS-30-CP
150mm Open V Joint 150mm Shiplap Cladding 300mm Shiplap Cladding		20mm Cladding Trim Nails for cladding trims Application as cladding system	SS-20-CN
Eaves Protection & OFVS systems	Fixing detail	Fixing type	Product ref.
UNIVENT & AEROVENT	600mm centres	30mm Cladding Nails	SS-30-CN
TOPGUARD	200mm centres	30mm Cladding Nails	SS-30-CN
TOPVENT MAX	200mm centres	50mm stainless steel annular ring shank	SS-50N

NOTE: Unless otherwise stated, all fascia/soffit fixing centres should not exceed 600mm centres

General		
Expansion Gap	White Foils & Colours	5mm per board end 8mm per board end
Fixing Centres	Replacement Fascia - 16mm+	2 per fixing centre, max 600mm centres, 65mm polytop nails (or 65 / 50mm x 4mm shank screws), austenitic stainless steel (grade BS6105).
	Overcap fascia - 8mm+	2 per fixing centre, max 600mm centres, 50mm polytop nails (or 40mm x 4mm shank screws), austenitic stainless steel (grade BS6105).
Soffit	Soffit	Per fixing centre, max 600mm centres, 40mm polytop pins (or 40mm x 4mm shank screws), austenitic stainless steel (grade BS6105).
	Soffit wider than 300mm	Soffits up to 300mm wide require no additional fixing. Soffit boards over 300mm wide should be fixed at maximum 600mm centres along their length and 300mm centres across their width. Fix to adequate timber bearers.
Load Bearing	Fascia 16mm+	16mm - 25mm boards will support all eaves tiles in common usage in the UK (up 10kg load per 1m length of fascia) provided that the boards are installed within the requirements of the BBA certificate.
	Fascia <16mm	All fascia less than 16mm require a minimum 12mm marine plywood backing board.
Joint Fixing		Low modulus neutral cure silicone BS5889 Type A.
Gutter Fixing	For 16 - 25 mm boards	Fix gutter brackets directly into the board using, for each bracket, at least 2 x 10 gauge x 25mm long (parallel thread form) austenitic s/steel screws, ensuring that the screws penetrate the rear face of the board and that the bracket spacings do not exceed one metre.
Gutter Fixing	For 9mm boards	For the 9 mm board, gutter brackets are screwed through the fascia board onto rafter feet or other timber support.



Specifying White Cladding Installations



Celufarm's cladding systems are ideal for a wide variety of internal and external applications. The system is offered complete with all trims, fixings and components to ensure a high quality, aesthetically appealing finish. Cladding is an ideal means of covering large areas with a durable, maintenance free solution which will stay looking good for years. It never needs painting and is highly suitable for areas where future access could prove difficult or costly. The design features within the system mean that cladding offers a visually appealing alternative to traditional materials, whether in domestic or commercial applications. Popular products within the cladding range and the principal elements of installation are detailed here.

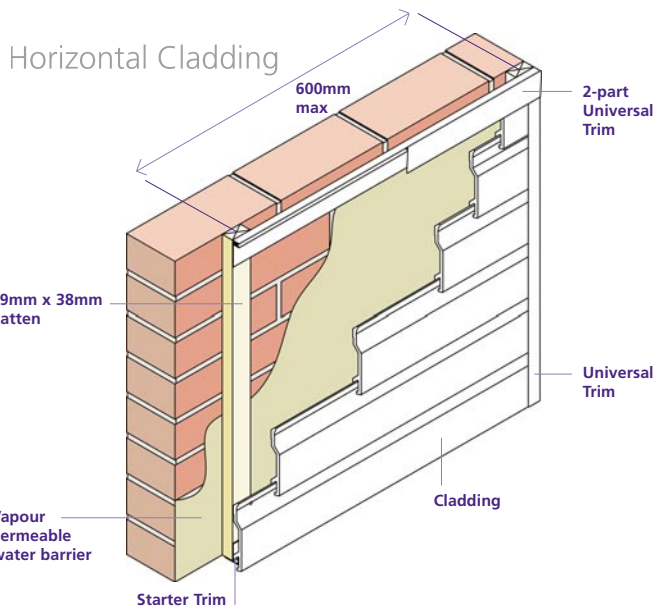

TECHNICAL CONSIDERATIONS - Installation

The Celufarm co-extruded PVC-UE cladding system is suitable for horizontal, vertical and diagonal fixing, as a decorative & protective external facing, over a timber stud or masonry wall.

When used over a sheathed timber stud frame or over a masonry or block substrate, the cladding should be fixed to preservative treated, good quality timber battens (measuring not less than 19mm by 38mm) rigidly fixed to the substrate at 600mm centres or closer.

Installation takes place by fixing trims around the periphery of the area to be clad followed by installation of the cladding planks.

Planks are fixed using stainless steel annular ring shank nails positioned in the groove which runs along the length of the cladding plank. Nailing takes place from the centre of each plank working outwards.

Subsequent planks are fitted over the preceding planks ensuring that the tongue-and-groove joint is firmly closed so that the nail heads are concealed by the overlap. To avoid distortion in service, care should be taken not to install the cladding in extremes of temperature (i.e. below 5°C or above 25°C) and to allow adequate expansion gaps of 5mm per plank end for expansion.

The cladding must be installed to provide a minimum ventilated air space of 19mm between the cladding and the backing wall. This satisfies both NHBC requirement for a minimum 10mm wide ventilation cavity and the Foundation 15 clause for a minimum 19mm cavity to be maintained between claddings and sheathing.

Horizontal battens used to support trims at the base of installations or at window heads, require 10mm diameter drainage holes at 1000mm centres.

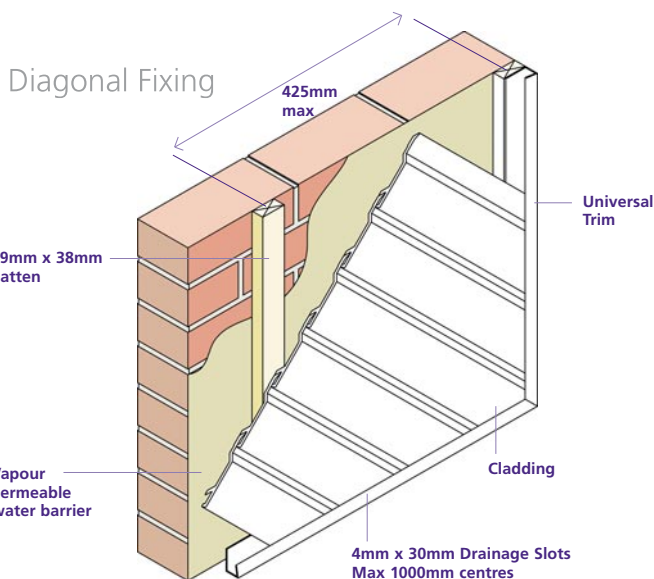

White Cladding Installations

When cladding is used in exposed locations (eg buildings above 10 metres in height, buildings on unprotected sites or in open countryside) it is recommended that batten spacing be reduced, particularly at the corners of the building, in order to increase the resistance to wind suction. the cladding is suitable for use above ground-floor level, and at ground-floor level in private areas where there is some incentive to exercise care.

It is not recommended for use at ground-floor level in public areas where it may be exposed to vandalism and general misuse. PVC-UE cladding installations are not air, water or water vapour tight. When used on timber stud walls the product must be backed by a breather membrane acting as a vapour-permeable water barrier, incorporated behind the cladding under the supporting battens.

This barrier must meet the requirements of BS4016: 1972 and have a vapour resistance less than 0.6 MNsg-1 when calculated from results carried out at 25°C and a relative humidity of 75%, in accordance with BS3177: 1959.

Where the product is used as a decorative facing attached to weathertight masonry walls, a water barrier is not necessary as the amount of water that will penetrate the cladding will be small and will not have an adverse effect on the wall.

Behaviour in relation to fire

When tested to BS476: Part 6: 1981 Celufarm white PVC-UE cladding planks achieved a fire propagation index of 15.4 with sub indices and of 7.6, 6.4 and 1.4 respectively.

Celufarm PVC-UE cladding is suitable for use as cladding on the external walls of buildings less than 20m in height (England & Wales) or 15 metres in height (Scotland) provided that the wall is 1 metre or more from the relevant boundary.

The product is suitable for use on the external walls of buildings in Northern Ireland less than 15 metres in height provided the wall is 1 metre or more from the relevant boundary, but excluding use on buildings of purpose group VII (assembly buildings) having more than one storey, at situations up to 7.5m above the finished surface of any adjoining roof or other part of the building to which persons have access.

The product is suitable for use as a cladding on the external walls of buildings 20 metres or more in height (England & Wales) or 15 metres or more in height (Scotland) provided that the wall is 1 metre or more from the relevant boundary and the cladding does not extend higher than 20 metres (England & Wales) or 15 metres (Scotland).

Vertical Cladding

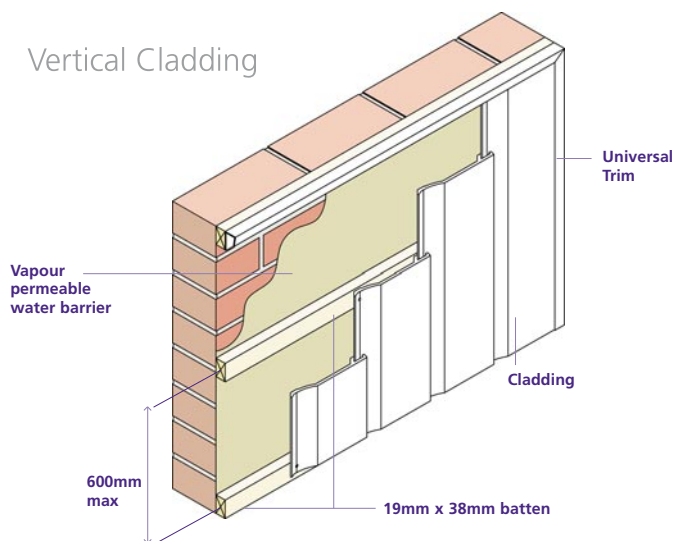

The product is suitable for use on external walls of buildings in Northern Ireland which are 15 metres or more in height provided the wall is 1 metre or more from the relevant boundary and the cladding does not extend higher than 15 metres, but excluding use on buildings of purpose group VII (assembly buildings) having more than one storey, at situations up to 7.5 metres above the finished surface of any adjoining ground, or of any adjoining roof or other part of the building to which persons have access.

When tested in accordance with BS476: Part 7: 1987, the white co-extruded material achieved a Class 1Y rating.

Although the surface spread of flame across the surface of the PVC is limited, the material does tend to char and may fall away when exposed to fire. Due consideration should always be given to any combustible material behind the cladding, which may become exposed in the event of a fire.

CE Marking

CE Marking requires that cladding be tested for its reaction to fire. Celufarm PVC-UE cladding with PVC-U skin achieves a Classification of Reaction to Fire Performance: D-s3, d2/AVM.

PVC cladding installed over timber framing now carries BRE A+ rating. This allows the specifier to claim the maximum three points available under the CSH for just such an external wall system.

Permissible dynamic wind pressures (Pa)

Length of fixing nail (mm)	Cladding Profile	
	100mm Open-V	150mm Shiplap
30	2650	1750
25	1750	1150

White Cladding Installations

Trim Locations and Installation

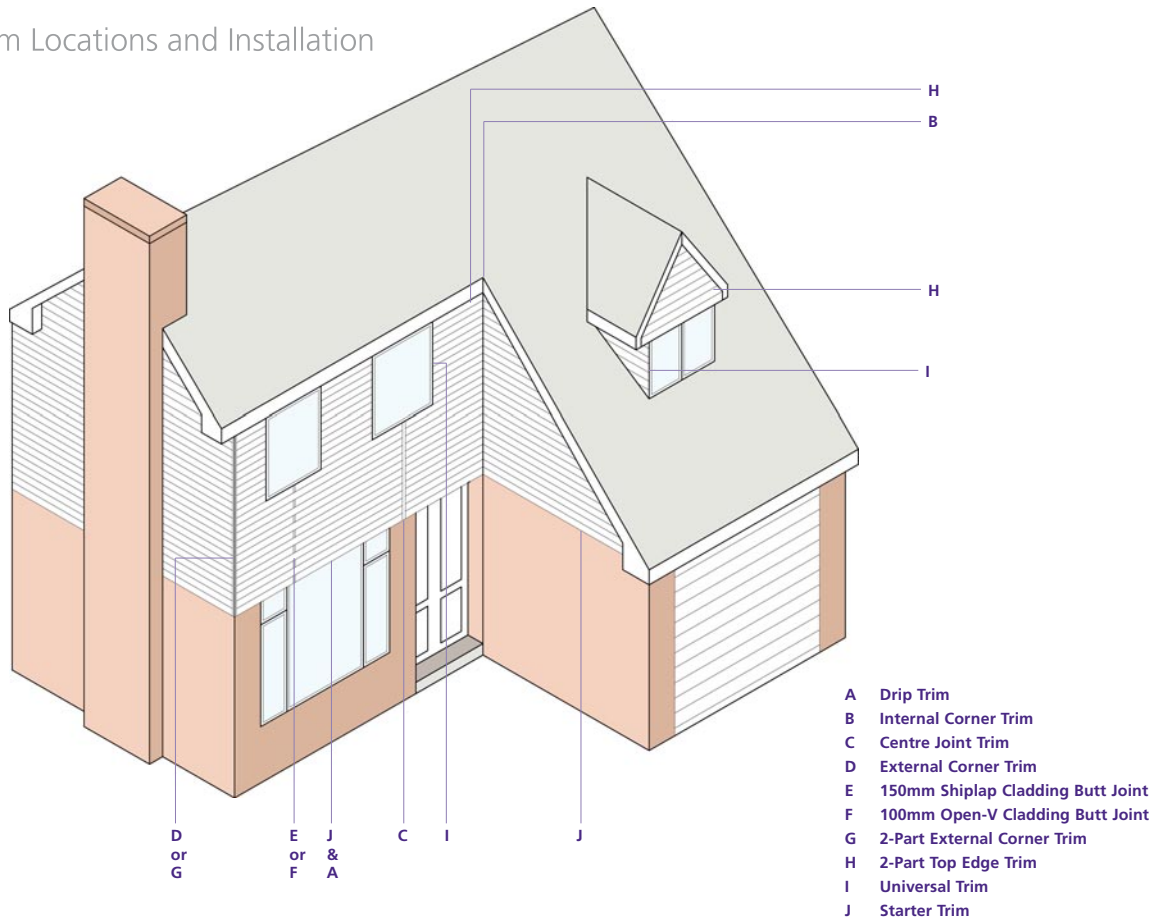

Trims Installation

Starter Trim - Horizontal Installation

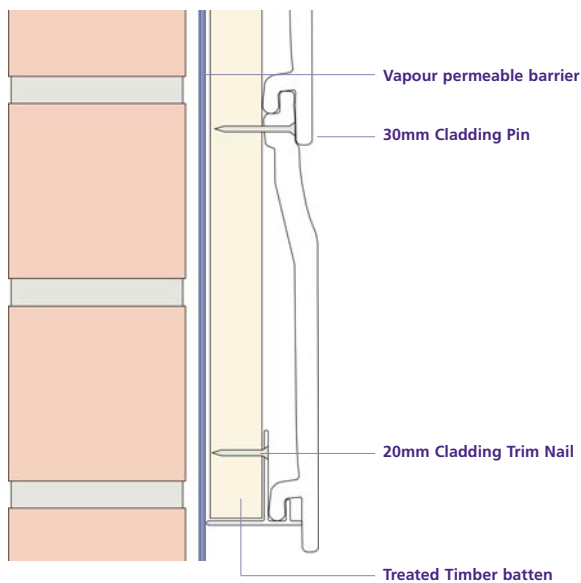

Starter Trim - Vertical Installation

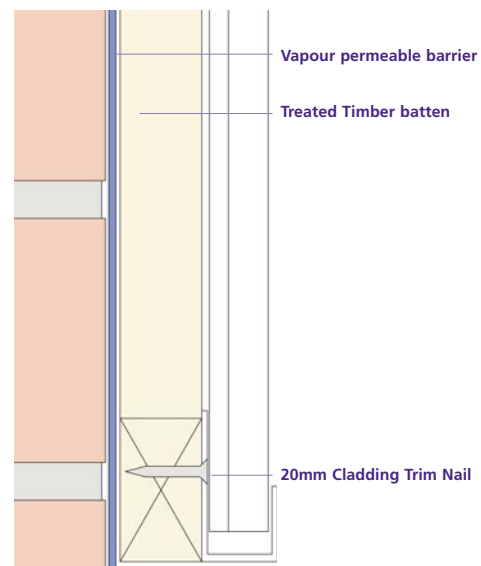

NB. Universal channel must be pre-slotted to allow for drainage

White Cladding Installations

Trims Installation

Universal Channel- General Edge Installation

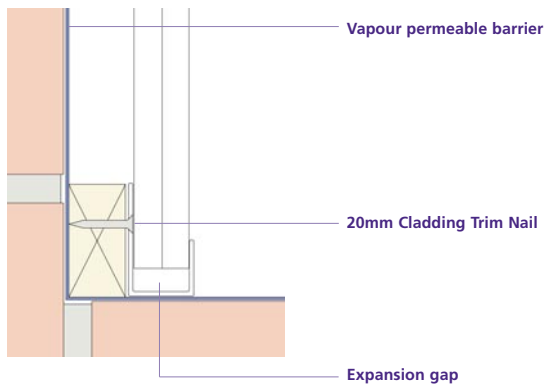

2-Part Top Edge Trim - Vertical Installation to Soffit

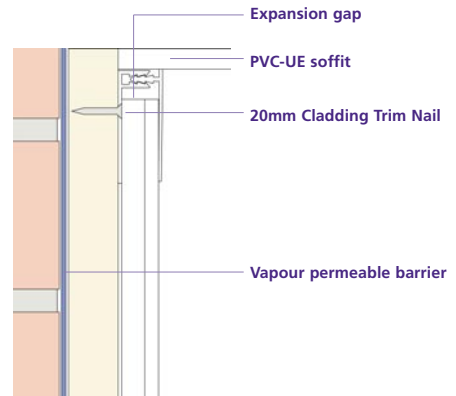

Centre Joint Trim Installation

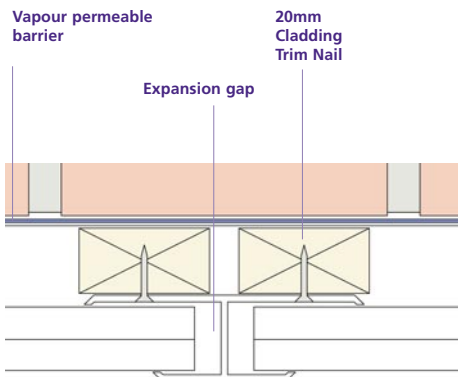

Universal Edge - Vertical Installation

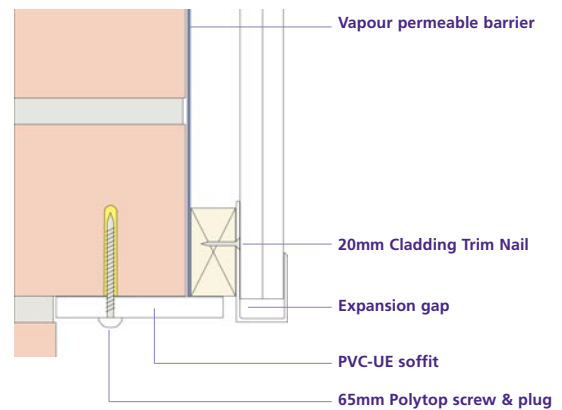

2-Part Top Edge Trim - Horizontal Installation

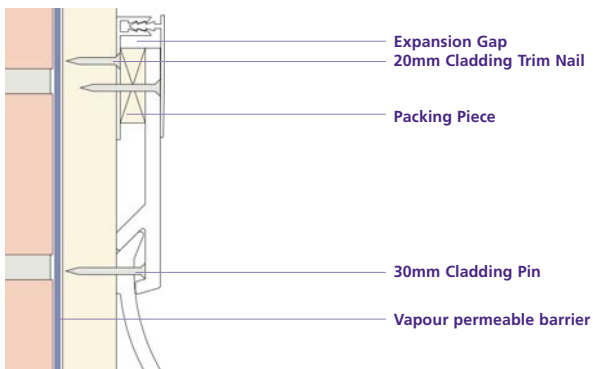

2-Part Top Edge Trim Installation to Window Cill



White Cladding Installations

External Corner - Horizontal Installation

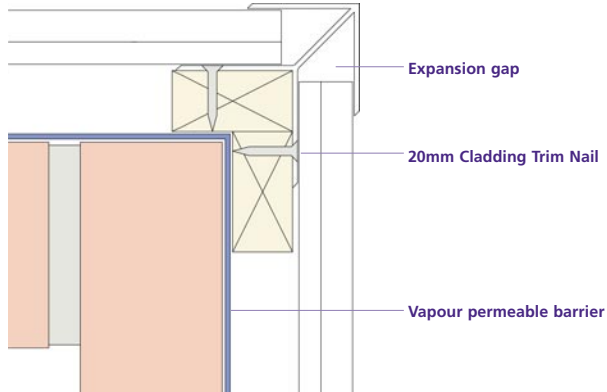

External Corner - Vertical Installation

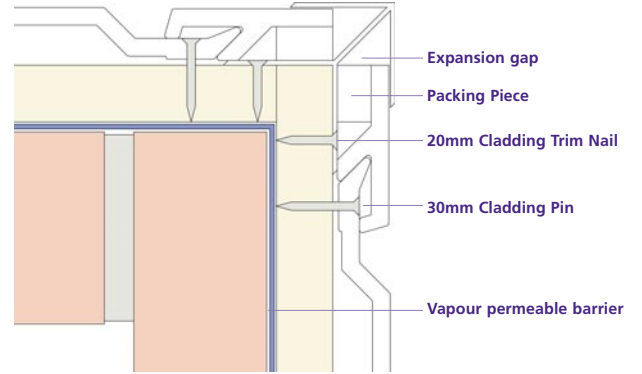

2-Part External Corner - Horizontal Installation

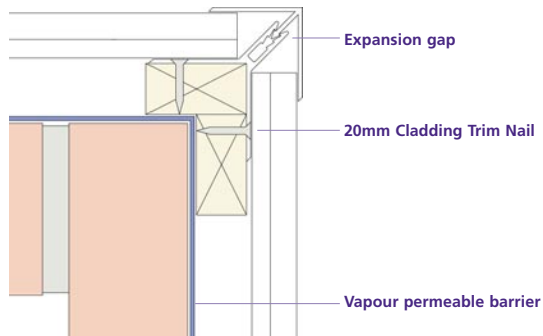

2-Part Corner - Vertical Installation

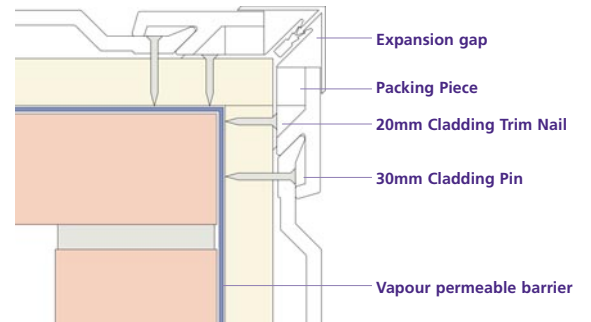

Internal Corner - Horizontal Installation

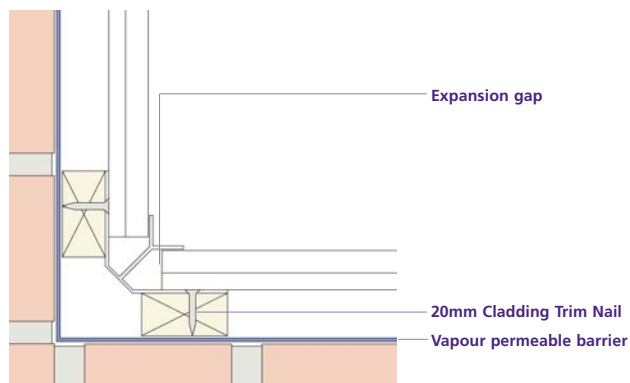

Internal Corner - Vertical Installation

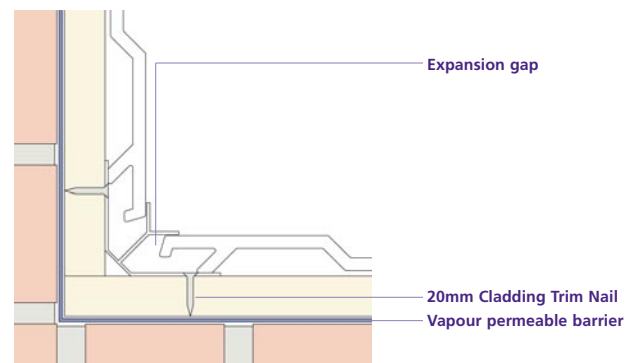

White Cladding Installations

Cladding System

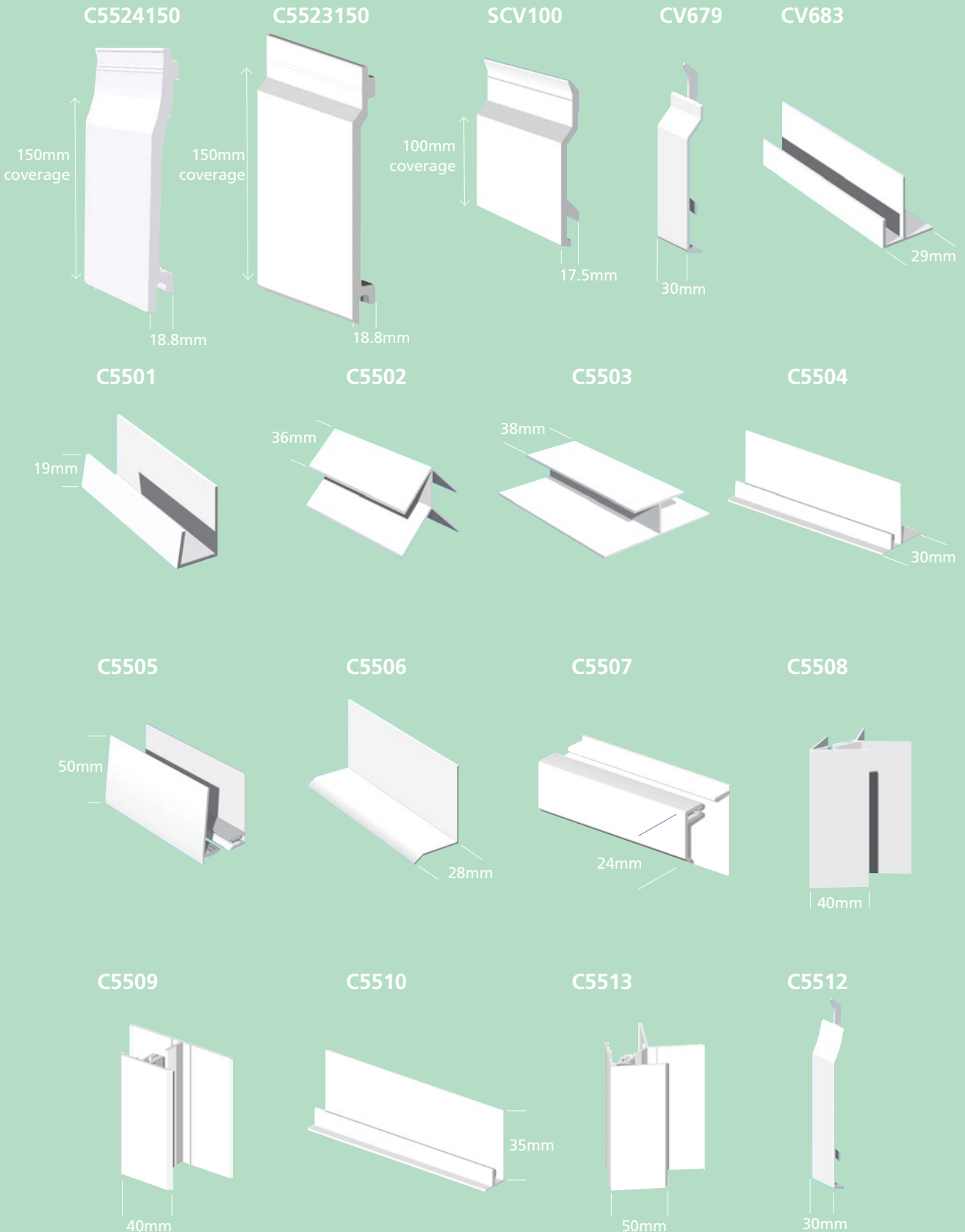

Fixing Summary - White Cladding

Fixing Details		
Batten fixings	into masonry: into steel: into timber:	Hammer screws Self-tapping screws Plated woodscrews.
Cladding fixings	30mm stainless steel Cladding Nails.	SS-30-CN or SS-30-CP
Trim fixings	20mm stainless steel Nails.	SS-20-CN
Breather membrane substrate.		To be positioned behind the batten system against the

- If Fixing Insulation Behind Important Points Which Must Always Be Observed:**
- Ensure cladding batten system is fully supported cladding system
 - Fix at recommended fixing centres
 - Always detail a suitable secondary waterproofing material e.g.vapour permeable breather membrane to maintain a watertight structure
 - The membrane should be positioned on the external face of the insulation between the insulation and the cladding
 - Maintain the correct statutory airspace behind the cladding system

Area Calculations			
Cladding:	Product Code:	5m Lengths Required Per Square Metre:	Coverage Per Linear Metre:
Open V Joint Cladding (100mm)	SCV100	2.0	0.1m ²
Open V Joint Cladding (150mm)	C5523 150	1.4	0.15m ²
Shiplap Cladding (150mm)	C5524 150	1.4	0.15m ²

Fixing Centres			
Cladding:	Product Code:	Batten / Fixing Centre:	Product Code:
Single Plank	SCV100, C5223 150 & C5224 150	1 per fixing centre, max 600mm centres	SS-30-CN or SS-30-CP
Double Plank	C5224 300	1 per fixing centre, max 300mm centres	SS-30-CN

All fixings to be A4 marine grade, austenitic stainless steel (grade BS6105)

General		
Battens	White plain cladding Foiled cladding	Minimum 19mm x 38mm (25mm x 38mm recommended) Minimum 50mm x 38mm (or 2 x 25mm x 38mm)
Ventilation	White Foils	Allow a minimum of 19mm ventilated air space behind the back of all cladding installations. This satisfies the NHBC requirement for a minimum 10mm wide ventilation cavity to be maintained between claddings and sheathing. Allow a minimum of 50mm ventilated air space behind the back of all cladding installations
Expansion Gap	White Foils	5mm per board end 8mm per board end
Joint Fixing Installation Temperature		Low modulus neutral cure silicone BS5889 Type A To be installed between 5°C & 25°C temperatures

Fire Rating			
	Finish	Thickness (mm)	Class
BS476 Part 7	White	6mm	1Y
BS476 Part 7	White / Coloured	7mm	2Y
EUROCLASS BS EN 13823 & BS EN ISO 11925-2	White / Coloured	6 / 7mm	D-s3, d2

Celutext Textured Cladding Installations



For Celutext textured cladding, standard fitting instructions can be followed. However, due to the differing sizes and colours available in the Celutext range, slightly modified batten fixings are required. Where required, ensure breather membrane is positioned beneath the batten system against the substrate.

Battens

- Set out and fix 25mm x 38mm tannalised battens vertically.
- Ensure battens are parallel straight and level.
- Fix battens to the substrate at 300mm maximum centres. (600mm for 150mm single planks)
- Fix a tannalised batten along the top of the installation.
- No batten is needed along the base of the cladding system because it relies on this opening to dispel excess moisture and to be used as a point of ventilation.

Trim Installation and Order of Work

- Fix the starter trim to the battens at the base of the installation with 20mm A4 stainless steel nails.
- The starter trim is designed to locate the first cladding plank.
- Measure and cut to size the vertical universal trim or corner trim notch out at the rear of the trim.
- Ensure that the trim is straight and plumb and fix onto batten with A4 20mm stainless steel fixings at 250mm-300mm intervals.
- **Trims are designed to take up expansion - ensure a 5mm gap between board edges/ends and trim stops for White cladding and 8mm for RAL9001, RAL1015, RAL7035 and X002.**
- Note there are two part versions of the vertical trims for use with horizontal and vertical cladding applications.
- Measure, cut and fix the top edge trim male extrusion to the top of the installation between the two vertical trims. Ensure you notch out the rear of the vertical trim to accommodate the male top edge extrusion.
- The installation is now ready to accept the first cladding plank.
- Measure first cladding plank ensuring that there is the correct gap left on either end of the plank for expansion.
- Before fixing plank locate groove section of the cladding plank into the location lip of the starter trim.
- Ensure plank is straight and level using a spirit level.
- Fix plank to each batten centre using A4 30mm stainless steel nails or 8-gauge x 30mm stainless steel countersunk headed screws.
- Ensure fixings pass through nail/screw guideline groove as the boards are a concealed fix.
- Locate second board, ensure groove of second board covers the tongue of the first board fully as not to show nail/screw heads.
- Follow this procedure until you reach the top of the installation, ensuring that each board is located properly.
- Ensure the installation is checked for level every three boards.
- Measure width of last board.
- Cut down last board and use the off cut tongue of the board as packing material. This will be spot glued (Cynoacrylate adhesive) to the back of the last cladding plank and then nailed through into the top batten once located.
- Locate top cladding plank & fix through plank into top batten.
- Cut and snap on female part of trims to the vertical male extrusion ensuring that the trim finishes at the top of the installation.
- Measure cut and snap on the top edge trim ensuring that the trim is fixed between the two vertical trims.

Batten Installation - Celutext Only

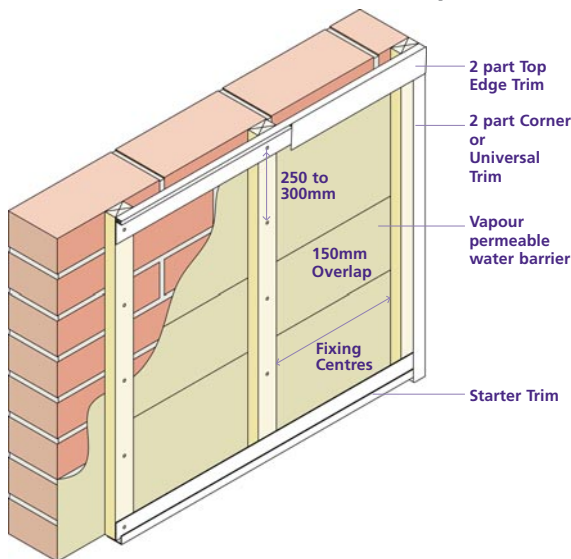

White - W

Cream - RAL9001

Sand - RAL1015



Light Blue - X002

Light Grey - RAL7035

Celutex Textured Cladding Installations

Vertical cladding

The same preliminary work as a horizontal cladding application will need to be completed before cladding can commence.

Preliminary work

- Secondary waterproofing membrane.
- Batten orientation and spacing.
- Battens to be installed horizontally for a vertical cladding application.
- A top batten and bottom batten are required.

Method

- Fix battens at the correct 300mm centres. (600mm for single planks)
- Pack out battens where necessary to ensure they sit straight & level.
- Measure, cut and fix drip trim to base of installation to act as a first location for the cladding plank.
- It is important to use two part trims on a vertical cladding application.
- Measure, cut and fix universal trim male extrusion to vertical edges of installation (flat section panel application).
- Measure, cut and fix universal trim to top of cladding installation.
- Measure and cut first cladding plank ensuring that there is 5 / 8mm removed from each end of the plank for expansion.
- Fix first plank with A4 30mm stainless steel nails or A4 – 8 gauge x 30mm A4 stainless steel screws ensuring that the plank sits neatly inside the vertical end trim to start the cladding line. The female part of the trim when snapped on will locate the groove intersection of the cladding board. It is advisable to nail through the base of the board to hold it in position, then snap on the trim female part to hide the fixings.
- Ensure the cladding board is plumb using a spirit level.
- Nail/screw the first board through the nail/screw groove guide lines on the board at every batten centre.
- The boards are a concealed fix so ensure the nail/screw heads are flush with board and through the nail/screw groove guide.
- Work from left to right of the installation and measure cut and fix each board in turn.
- The boards should be checked for plumb every three boards.
- Also check that each board is located properly.
- Measure and cut the last board allowing for the correct expansion gap & engage it into the trim. The tongue of the board will be used as a packing piece to ensure the board is fixed securely into the trim.
- Cut and spot glue the tongue of the board (Cynoacrylate adhesive) to the rear of this last board.
- Fix the board with A4 grade 30mm stainless steel nails or A4 - 8 gauge x 30mm stainless steel screws through the face beneath where the finishing trim is being located.
- Measure, cut and snap-on vertical trims.
- Measure, cut and snap-on the horizontal top edge trim to finish installation.

Diagonal cladding

The same preliminary work & installation techniques as a horizontal cladding installation will need to be observed with a few differences.

Method

- Reduce batten centres to 210mm.(450mm for 150mm single planks).
- Measure, cut and fix drip trim or universal trim to base of installation to act as a first location for the cladding plank.
- Use 2-part Centre Joint Trim fixed on twin battens if cladding is to be mirrored.
- Use first plank as a template to mark out second plank and so on.

Wall Starter Trim Installation

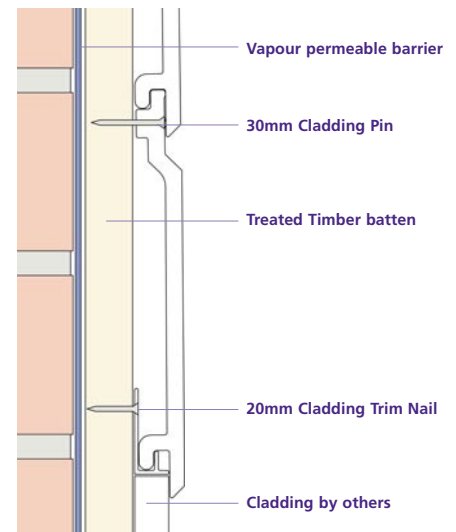

2pt Centre Joint Trim Installation

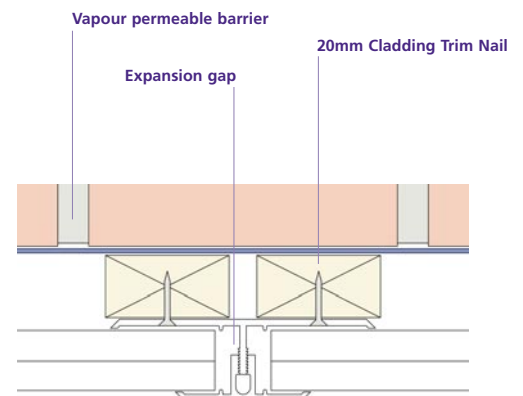

2pt UniversalTrim Installation

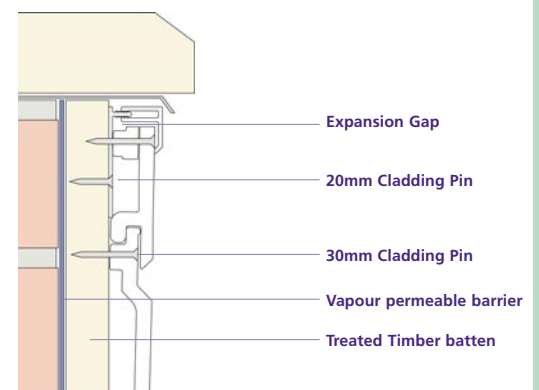

Celutex Textured Cladding Installations

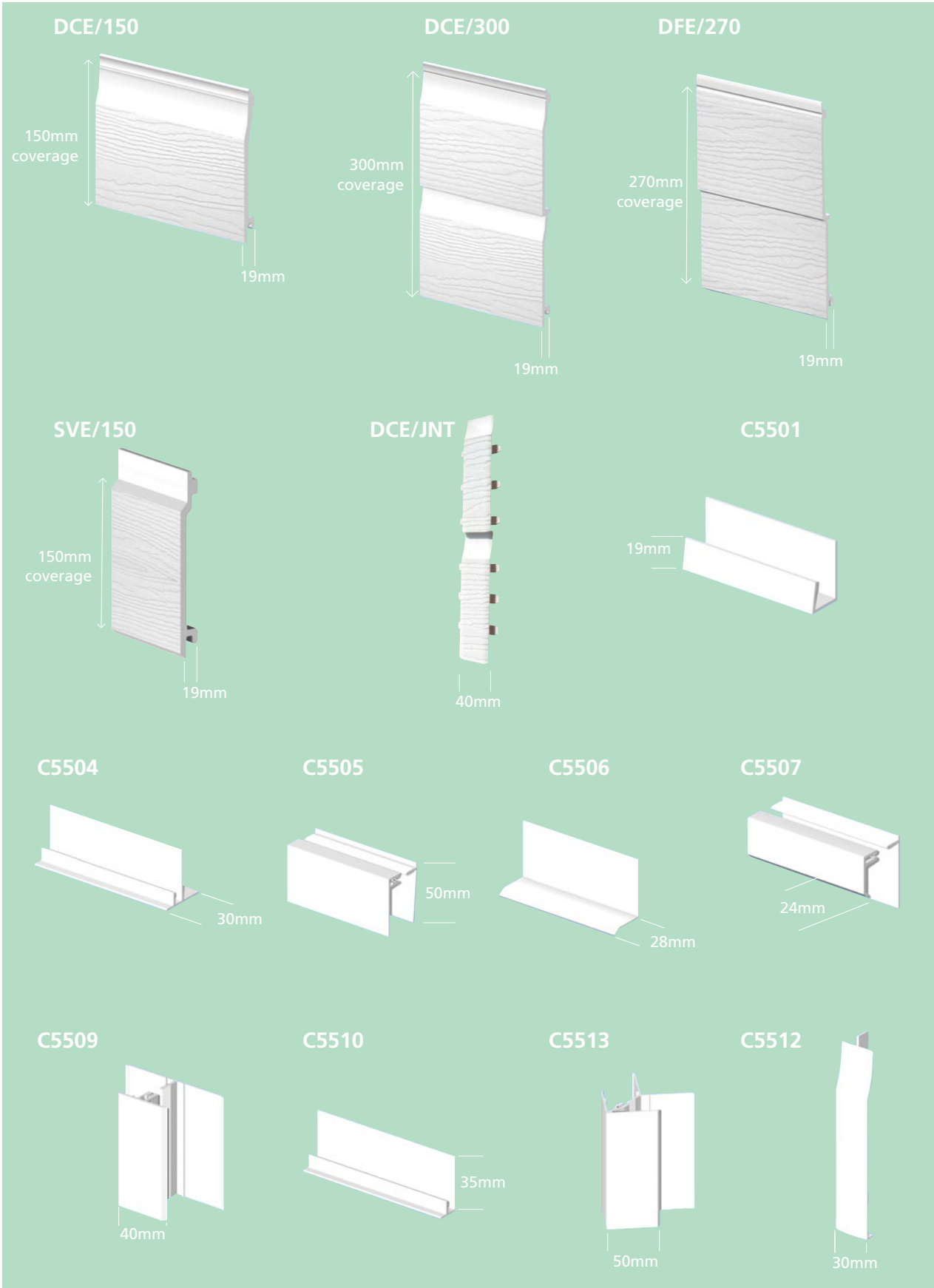

Fixing Summary - Celutex Textured Cladding

Fixing Details		
Batten fixings	into masonry: into steel: into timber:	Hammer screws Self-tapping screws Plated woodscrews.
Cladding fixings	30mm stainless steel Cladding Nails.	SS-30-CN or SS-30-CP
Trim fixings	20mm stainless steel Nails.	SS-20-CN
Breather membrane		To be positioned behind the batten system against the substrate.

- If Fixing Insulation Behind Important Points Which Must Always Be Observed:**
- Ensure cladding batten system is fully supported cladding system
 - Fix at recommended fixing centres
 - Always detail a suitable secondary waterproofing material e.g.vapour permeable breather membrane to maintain a watertight structure
 - The membrane should be positioned on the external face of the insulation between the insulation and the cladding
 - Maintain the correct statutory airspace behind the cladding system

Area Calculations			
Cladding:	Product Code:	5m Lengths Required Per Square Metre:	Coverage Per Linear Metre:
Textured Open V Joint Cladding	SVE/150	1.4	0.15m ²
Textured Shiplap Cladding - 150mm	DCE/150	1.4	0.15m ²
Textured Shiplap Cladding - 300mm	DCE/300	0.7	0.3m ²
Textured Feather Edge Cladding	DFE/270	0.75	0.27m ²

Fixing Centres			
Cladding:	Product Code:	Batten / Fixing Centre:	Product Code:
Celutex Textured Single Plank	SVE/150 & DCE/150	1 per fixing centre, max 600mm centres	SS-30-CN or SS-30-CP
Celutex Textured Double Plank	DFE/270 & DCE/300	1 per fixing centre, max 300mm centres	SS-30-CN or SS-30-CP

All fixings to be A4 marine grade, austenitic stainless steel (grade BS6105)

General		
Battens	Celutex	Minimum 25mm x 38mm
Ventilation	Celutex	Allow a minimum of 25mm ventilated air space behind the back of all cladding installations
Expansion Gap	White Colours	5mm per board end 8mm per board end
Joint Fixing		Low modulus neutral cure silicone BS5889 Type A
Installation Temperature		To be installed between 5°C & 25°C temperatures

Fire Rating			
	Finish	Thickness (mm)	Class
BS476 Part 7 EUROCLASS BS EN 13823 & BS EN ISO 11925-2	White / Coloured White / Coloured	7mm 7mm	2Y D-s3, d2

Internal Applications for Celuform Products

Celuform makes a wide range of products for interior applications and to support the window fitting industry. This range includes window boards, reveal liners, trims, architraves and skirtings.

PVC-UE products used in interior and window application offer several key advantages over traditional building materials. PVC-UE products:

- are durable and long lasting
- are lightweight, quick and easy to install
- do not need painting or any other form of treatment
- can be worked with conventional tools by traditional trades

GENERAL

Installation Conditions

Celuform internal trim profiles should only be fixed within the recommended installation temperatures of 5°C and 25°C. Boards should not be sprung between fixed points. A gap of 1mm/m at each board end should be allowed for thermal expansion on white boards and 1.3mm/m on Woodgrain foiled boards. It is recommended that products are only used in circumstances where the maximum internal temperature will not exceed 30°C.

Prior to installation it should be ensured that the substrate is sound, level and free from dust or moisture. The relevant profile should be cut to size and mitred if required.

Cutting The Material

Workability of PVC-UE and PVC-U is similar to that of timber. All Celuform products can be sawn, drilled and planed using traditional joinery tools. Hand saws should have a fine tooth blade. Power tools should be run at speeds similar to, or in excess of, those used for timber. When using power tools, a coarse particle dust mask, eye protection and light industrial gloves should be worn.

Repairs and Remedial Work

In the event of a profile becoming damaged in service, it is recommended that the damaged profile be removed and replaced to ensure full product performance.

In-Service Maintenance

In order to maintain the as-new finish it may be necessary to wash the profiles occasionally to remove surface dirt. This can be done easily with soap and water. When wiping over, use a soft cloth and never use solvent-based or abrasive cleaners.

Storage

Products should be stored on a clean level surface in stacks not exceeding 1m in height and restrained from collapse. If stored externally, the product must be kept under cover.

Woodgrain

It is not recommended to use Cyanoacrylate adhesive (Super Glue) on foiled products.

Selection of Boards

Celuform's 9mm thick boards are suitable for the majority of applications. However in certain applications, it may be necessary to consider the use of thicker boards, e.g. VAN & ELG, with their superior strength and rigidity. Consideration should be given in the following circumstances:

- New Build type applications where a board is required to bridge a cavity.
- Fixing over irregular or uneven substrates.
- Situations where boards may be subject to above average loading.

Esprit reveal liner, silicone fix with window board channel

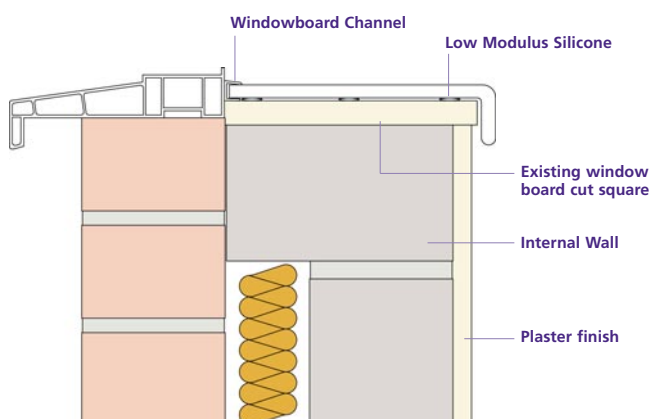

ELU windowboard, silicone fix with varitrim

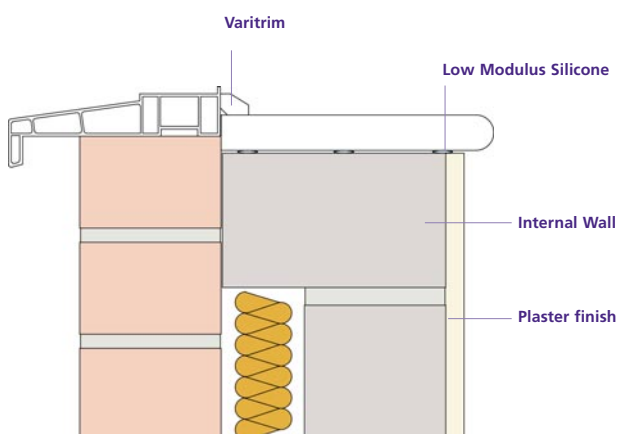

Windowboard and Internal Trims

INSTALLATION

Reveal Liner

Window board channel should be fixed to the inner surface of the window frame using fixing screws suitable for the window frame material, in lengths corresponding to the reveals to be cloaked. Reveal liner may also be installed without the use of window board channel by butting up directly to the inner window frame.

Packing pieces should be introduced under the board to level it out if required. Continuous 6mm wide beads of Low Modulus Silicone should be applied to the front, middle and rear of the underside of the board.

The board should be bedded into the substrate and, where used, located into the window board channel. The product may require to be held in place to allow the silicone to skin.

The installation should be finished by filling all gaps with acrylic Sealant. Internal reveal corners can be trimmed using a slimline internal corner joint, applied after installation of the boards and secured using Low Modulus Silicone. Exposed board ends are trimmed using end caps secured with Low Modulus Silicone or Cyanoacrylate adhesive.

Window Boards

Internal window boards may be fixed over existing window board or directly to the internal building construction, using either of the methods detailed. On New Build or when fixing over uneven substrates, thicker boards such as ELG and VAN are recommended.

Window board channel should, if required, be fixed to the inner surface of the window frame/cill, using fixing screws suitable for the window frame material. Where required, packing pieces should be placed under the window board channel for support. Window board may also be installed without the use of window board channel by butting up directly to the window frame/cill. Packing pieces should be introduced under the board to level it out if required. Window board channel is the recommended option due to its positive location and the lack of a need for further trimming.

Continuous 6mm wide beads of Low Modulus Silicone should be applied to the front, middle and rear of the underside of the board. The board should be bedded onto the substrate and where used, located into the window board channel. The board may require to be held in position to allow the silicone to skin. The installation should be finished by filling all gaps with Acrylic sealant. Visible window board ends are finished using end caps which may be applied with Low Modulus Silicone or Cyanoacrylate adhesive. Note: It is recommended that the overhang on all window board installations be kept to a minimum.

Skirting and Architraves

Low Modulus Silicone should be applied in a continuous 6mm bead to the upper part of the back of the profile, and peaks of the same silicone applied at maximum 250mm centres to the lower part of the profile. The profile is then bedded into position. The profile may require holding in position to allow the silicone to skin. The installation should then be finished by filling gaps with acrylic sealant.

Finishing Trims

To provide a finished appearance to installations, PVC-UE trims should be used. Trims are installed using Low Modulus Silicone. Following application of silicone to the rear of the trims, they are bedded into position and when required held in position to allow the silicone to skin.

ELG windowboard to timber frame with quadrant

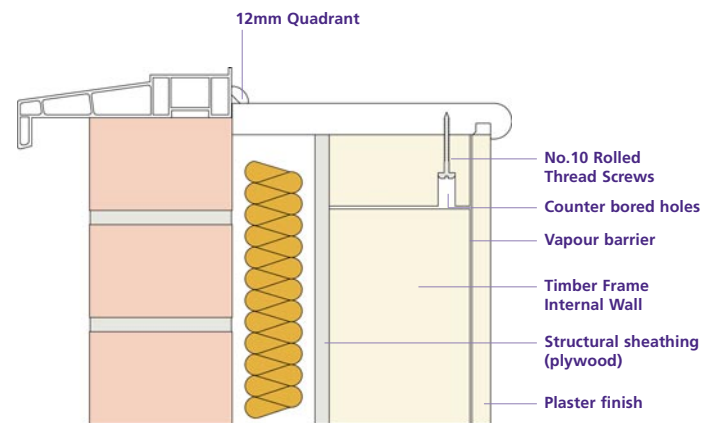

Supaboard, silicone fix to new / existing window board

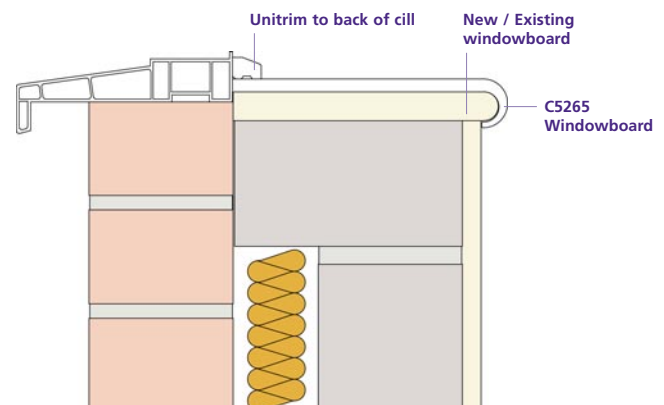

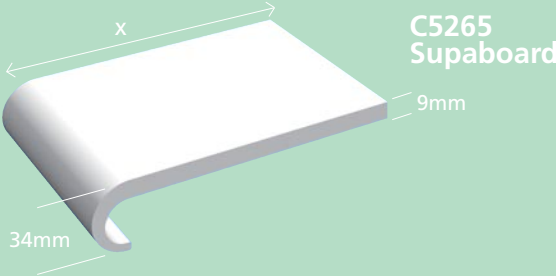
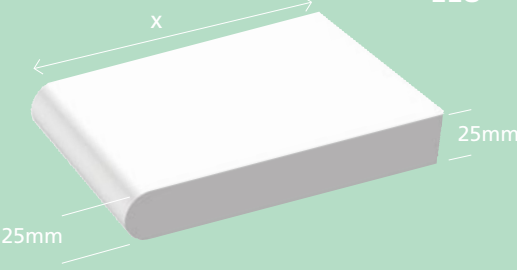
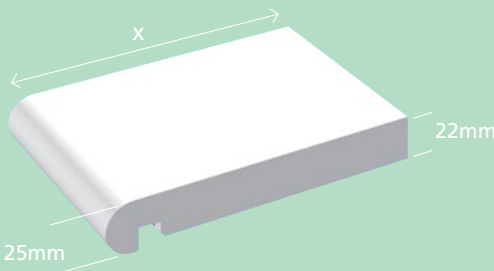
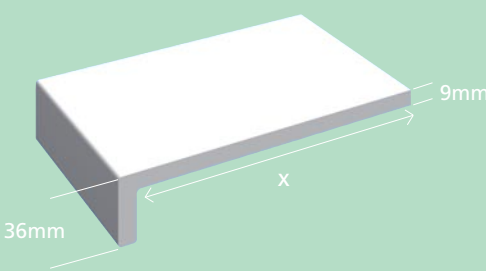

Windowboard Range

	Code	Dimension X
 <p>C5265 Supaboard</p>	C5265 C5265150	150mm
	C5265175	175mm
	C5265200	200mm
	C5265225	225mm
	C5265250	250mm
	C5265405	405mm Double Leg
 <p>ELU</p>	ELU ELU100	100mm
	ELU175	175mm
	ELU200	200mm
	ELU225	225mm
	ELU250	250mm
	ELU300	300mm
	ELU405	405mm Double Nose
 <p>ELG</p>	ELG ELG150	150mm
	ELG175	175mm
	ELG200	200mm
	ELG225	225mm
	ELG250	250mm
	ELG300	300mm
	ELG405	405mm Double Nose
 <p>DLR</p>	DLR DLR100	100mm
	DLR125	125mm
	DLR150	150mm
	DLR175	175mm
	DLR200	200mm
	DLR225	225mm
	DLR250	250mm
	DLR300	300mm
	DLR400	405mm
	DLR450	450mm
	DLR500	500mm
	DLR550	550mm
DLR600	610mm	

*For full list of trims please see current price list.

Trim Range

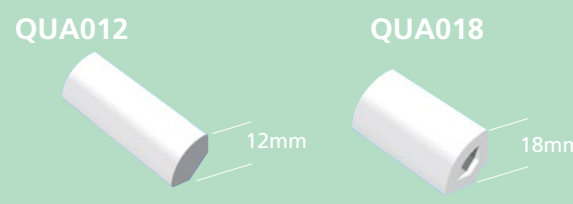
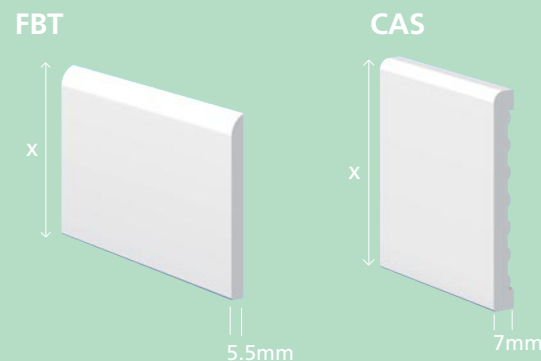
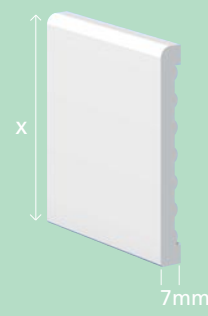
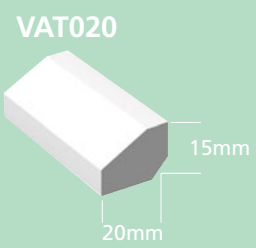
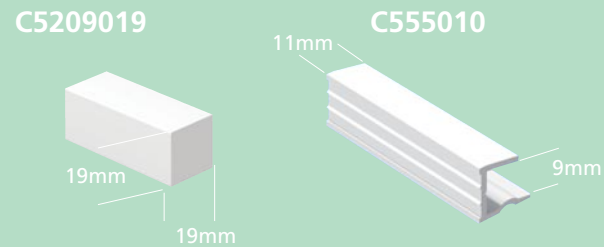
		Code	Dimension X
 <p>DSN028</p>		<p>DSN028 DSN028</p>	<p>28mm x 6mm D-section</p>
 <p>CRECT028</p>		<p>CRECT028 CRECT028</p>	<p>28mm x 6mm Rectangle</p>
 <p>QUA012 QUA018</p>		<p>QUA* QUA012 QUA019</p>	<p>12mm quadrant 18mm quadrant</p>
 <p>FBT CAS</p>		<p>FBT* FTB045 FTB065 FTB095</p>	<p>45mm Flat Back Architrave 65mm Flat Back Architrave 95mm Flat Back Architrave</p>
 <p>CAS*</p>		<p>CAS040 CAS060 CAS080 CAS090 CAS100</p>	<p>40mm Castellated Architrave 60mm Castellated Architrave 80mm Castellated Architrave 90mm Castellated Architrave 100mm Castellated Architrave</p>
 <p>VAT020</p>		<p>VAT020 VAT020</p>	<p>20mm x 15mm Unitrim</p>
 <p>C5209019 C555010</p>		<p>C5209019 C5209019</p> <p>C555010 C555010</p>	<p>19mm Square Trim</p> <p>9mm Window Board Channel</p>

*For full list of trims please see current price list.

Frequently Asked Questions

Celuform's technical team is always willing to offer advice and practical assistance with planned installations. Our team can guide you as to the most appropriate products, expected product life, ease of installation and more. We are also able to provide estimates in terms of bills of quantities and to supply full health and safety information about each product in the range. Where you have a particularly large or complex installation, please call on us at the planning stage. One of our area sales managers can then visit you to advise on the best options for your application.

In the meantime, here are the answers to the ten most frequently asked questions about Celuforms products and PVC-UE applications in general

1. With what do you recommend fixing cover and corner joints to fascia board?

A: Low Modulus Neutral Cure Silicone.

2. Has hollow soffit got a Class 1 Fire Rating?

A: No, whilst PVC-UE products in the Celuform range have, hollow soffit has not.

3. Are Woodgrain products guaranteed for external use?

A: Yes for 10 years and white products are guaranteed for 20 years.

4. Does Celuform supply vented soffit with an insect mesh?

A: Celuform does not recommend the use of mesh. The soffit vent slots comply with BS5250 with regard to minimum slot size. Further reduction in slot size via the use of mesh may result in the vent area becoming blocked by airborne dust and debris.

5. What expansion gaps are required when installing Celuform products?

A: For white products there should be an expansion gap of 5mm per board end (eg. 2 boards butting up to each other in the same plane = 10mm gap). When installing Woodgrain product this gap is increased from 5mm to 8mm per board end.



6. Are PVC cladding products suitable for use in swimming pool buildings?

A: Yes, contact with swimming pool water is not detrimental to PVC.

7. Is it better to install the thickest board available?

A: For a replacement installation, a 16mm fascia board will perform equally as well as thicker products, requiring no additional support and taking both gutter and tile loading. If the 16mm board chosen is VAN, it can be teamed with 9mm DLR bargeboard to give a cost effective performance installation.

8. What is the coverage of Celuform Shiplap and Open-V Cladding boards?

A: C5224 150 Shiplap = 150mm, C5224 150 Open V = 150mm, SCV100, Open-V = 100mm

9. What is the length of the leg on Celuform 'L Boards'?

A: Both VAN and DLR have the same length of leg, which is 36mm.

Product Characteristics

A) TECHNICAL DATA

Many of the applications for PVC foam profile are for wood-replacement products due to its ease of installation and the advantages of a low maintenance product. The principal products in the Celuform range are manufactured by co-extruding a highly weather-able PVC-U compound (skin) onto a PVC-UE compound (core), cooling and forming into the desired section.

In order to obtain a high quality product with the required stiffness, strength and impact performance, it is important to control foam density, skin thickness, surface finish and cell size distribution. Formulations contain a mixture of processing aid, thermal stabilisers, lubricants, pigment and filler in addition to the blowing agents required for foaming. The cellular structure is generated by the decomposition of chemical blowing agents, e.g. sodium bicarbonate (baking powder). The latest calcium organic stabiliser technology is utilised to provide optimal performance. Other products in the Celuform range (rigid profile and joints) are manufactured using conventional extrusion or injection moulding techniques.

OPTICAL PERFORMANCE

Colour

The surface colour of the profile shall be uniform and be within the optical limits as specified by Celuform's test procedure and specification for each particular colour.

Appearance and Finish

The profile shall be free from foreign bodies, cracks or sink marks when viewed by normal corrected vision at 90° to the surface and at a distance of 1 metre in normal diffused north light.

Subject to normal wear and tear, Celuform's PVC-UE and PVC-U profiles will retain their optical and mechanical properties for a period of at least 20 years for white and 10 years for Woodgrain foiled, with only minor changes in surface appearance. Additional care should be taken with foiled and colour finishes to ensure that correct installation procedures are followed.

CLEANING & MAINTENANCE

Celuform products are low maintenance and with the required care and attention will stay looking good for years to come. However, there are some external factors which may adversely affect the appearance of any PVC, especially after extended weathering:

- Solvent based cleaners
- Abrasive cleaners
- Environmental contamination e.g. dirt / pollen

In order to maintain the appearance, it will be necessary to wash the installation with warm soap and water to remove surface dirt. The frequency of this will depend upon the local environmental conditions. This cleaning should be carried out with copious amounts of soapy water to avoid any chance of scratching of the surface.

When wiping over **ALWAYS** use a soft cloth or sponge.

NEVER use solvent-based cleaners.

NEVER use abrasive cleaners.

Repairs and Remedial Work

In the event of a profile becoming damaged in service it is recommended that the damaged profile is removed and replaced to ensure full product performance.

DURABILITY

Colour Fastness

Accelerated weathering tests and natural exposure trials indicate that Celuform products are at least as durable as conventional window grade PVC-U profiles. White Celuform PVC-UE profiles are Kitemarked and satisfy UV stability and UV aged impact resistance requirements to BS7619:2010.

PHYSICAL PERFORMANCE

Flatness

When measured in accordance with BS7619:2010 the surface flatness over any 100mm distance does not exceed +/- 0.6mm.

Bowing

When measured in accordance with BS7619:2010 test procedure the maximum permitted bowing is 25mm over a 5 metre length. This is not applicable to products which, under their own weight, lie flat.

PHYSICAL PERFORMANCE

Dimensions (in mm)

Width (as cut)	Tolerance
0 - 50	±0.5
51-150	±1.1
151- 250	±1.7
251- 350	±2.2
Over 350	±3.3
Thickness	Tolerance
5 -12	+/- 0.5
Over 12	+/- 0.75
Length	Tolerance
5.0	+10 / - 0

Water Absorption

The PVC-U surface skin of Celuform Roofline profiles is unaffected by moisture. Due to the closed cell structure of the material cut ends are non-absorbent.

Thermal Movement

Linear thermal expansion when measured to BS4370 Part 3 Method 13 is less than 7 x 10⁻⁵/°C similar to that of rigid PVC-U.thermal movement.

Product Characteristics

Thermal Conductivity

Cellular foam profiles have a very low co-efficient of thermal conductivity, resulting in insulation properties better than timber boarding or gypsum plasterboard (K=0.06W/mC).

Chemical Resistance

Staining will result from contact with creosote or bitumen. Organic solvents and solvent based cleaning solutions will damage the surface finish.

Celuform PVC-UE profiles are liable to damage if attacked by aromatic solvents, ketones and esters. PVC-UE profiles are resistant to insect attack but may need protection during storage from vermin.

Fire Resistance

Celuform white cellular foam profiles do not support combustion and conform to the following specifications: Surface spread of flame BS476 Part 7 1997. Fire Propagation BS476 Part 6 1989 (see Fixing Summary table on opposite page). CE Marking requires that cladding be tested for its reaction to fire. Celuform PVC-UE cladding with PVC-U skin achieves a Classification of Reaction to Fire Performance: D-s3, d2/AVM.

Impact Resistance

All white Celuform PVC-UE profiles are Kitemarked and comply with the BS specification for falling weight impact resistance as specified by BS7619:2010.

Softening Point

The foamed PVC-UE material has a softening point of approximately 75°C.

STORAGE

Profiles are protected on the co-extruded surface by polythene lo-tac film, which should be removed immediately prior to installation. Celuform PVC-UE profiles are delivered in packs sealed in polythene sleeves, using coloured cellotape for ease of identification of the product shades. Pack quantities vary according to the profile and all packs carry a Celuform product code indicating product, quantity and date of manufacture.

All packs not in stillages should be unloaded by hand, stored flat in their protective packaging on a clean, level surface in stacks not exceeding 1 metre high and restrained from collapse.

Where the packs are stored externally, additional protection should be provided against the weather and accidental damage.

B) PVC AND THE ENVIRONMENT

PVC RESIN SYNTHESIS: PVC is one of the world's oldest plastics. It has evolved since the 1940s to become a much used, cost-effective, safe, adaptable and environmentally efficient material. In essence, salt and oil derivatives are combined to produce a plastic material specified for a broad range of applications across various market sectors.

Production processes are being continually improved. For this reason, the European industry, under the auspices of the European Council for Vinyl Manufacturers (ECVM), has signed a European Industry Charter, committing us all to tighter limits on emissions from PVC production plants.

PVC RESIN WASTE MANAGEMENT:

Plastics represent only 6% of municipal solid waste, of which the PVC component is about one tenth and is mainly composed of used packaging. It is known that the presence or absence of PVC in the municipal solid waste stream makes no difference to the levels of dioxins produced during incineration.

Developed countries generate some 500 kg of waste per person per annum. In the EU this represents 100 million tonnes of household waste annually. Plastic materials account for 6%, of which PVC itself accounts for 0.6% in total, i.e. 600,000 tonnes. In Western Europe only 30% is incinerated, most going to landfill.

A study of PVC undertaken by the TNO Institute of Environmental and Energy Technology in Holland on behalf of the European Commission's Director General emphasises that PVC can be incinerated safely and cleanly.

REPROCESSING PVC-U AND PVC-UE:

During any manufacturing process, a small percentage of scrap is generated. Celuform reprocesses this back into the manufacturing cycle without losing any of the excellent characteristics of our finished products. Long term durability, aesthetics, colour fastness and weather resistance are not affected. Celuform reprocesses 99.8% of all its incoming materials. The small amount of unusable scrap is disposed of, off site, at locally authorised and registered incinerators or land fill sites.

C) STANDARDS AND CERTIFICATION

Celuform's principal product ranges have all the necessary approvals for wide use in the majority of common domestic and commercial building applications.

British Board of Agreement

PVC-UE Roofline System :Certificate No.11/4835

PVC-UE Cladding System :Certificate No.11/4839.

BS Kitemark:

Celuform products are manufactured in accordance with British Standard 7619: 2010. License no. KM51726.

Company Standards:

Celuform's business and manufacturing resources have been assessed to and are operated under ISO 9001:2008, ISO 14001:2004 and BES 6001.

D) PRODUCT GUARANTEES

Celuform's white products are guaranteed for 20 years and woodgrains for 10 years provided that approved installation and maintenance instructions are followed. Copies of the guarantees which relate to Celuform products are available from the marketing team on 01724 400487.



General Fixing Summary

Roofline		
Expansion Gap	White	5mm per board end
	Foils & Colours	8mm per board end
Fixing	Replacement Fascia - 16mm+	2 per fixing centre, max 600mm centres, 65mm polytop nails (or 50mm x 4mm shank screws), austenitic stainless steel (grade BS6105)
	Overcap fascia - 9mm+	2 per fixing centre, max 600mm centres, 50mm polytop nails (or 40mm x 4mm shank screws), austenitic stainless steel (grade BS6105)
	Soffit	Per fixing centre, max 600mm centres, 40mm polytop pins (or 40mm x 4mm shank screws), austenitic stainless steel (grade BS6105)
Soffit Boards	Soffit wider than 300mm	Soffits up to 300mm wide require no additional fixing. Soffit boards over 300mm wide should be fixed at maximum 600mm centres along their length and 300mm centres across their width. Fix to adequate timber bearers.
Load Bearing load	Fascia 16mm+	16mm - 22mm boards will support all eaves tiles in common usage in the UK (up to 10kg per 1m length of fascia) provided that the boards are installed within the requirements of the BBA certificate.
	Fascia <16mm	All fascia less than 16mm requires a minimum 12mm marine plywood backing board.
Joint Fixing		Low modulus neutral cure silicone BS5889 Type A
Gutter Fixing 25mm	For 16 - 22 mm boards	Fix gutter brackets directly into the board using, for each bracket, at least 2 x 10 gauge x long (parallel thread form)austenitic s/steel screws, ensuring that the screws penetrate the rear face of the board and that the bracket spacings do not exceed one metre.
Gutter Fixing	For 9mm boards	For the 9 mm board, gutter brackets are screwed through the fascia board onto rafter feet or other timber support.

Cladding		
Expansion Gap	White	5mm per board end
	Foils & Colours	8mm per board end
Joint Fixing		Low modulus neutral cure silicone BS5889 Type A.
Fixing Centres	White	1 per fixing centre, max 600mm centres, 25 or 30mm x 2mm shank nails, austenitic stainless steel (grade BS6105)
	Foils	1 per fixing centre, max 400mm centres, 30mm x 2mm shank nails, austenitic stainless steel (grade BS6105).
	Celutex Embossed	1 per fixing centre, max 300mm centres for twin plank, (600mm for single plank) 30mm x shank nails, austenitic stainless steel (grade BS6105).
Battens / Ventilation ventilation	White	19 x 38mm battens. Allow a minimum of 19mm ventilated air space behind the back of all cladding installations. This satisfies the NHBC requirement for a minimum 10mm wide cavity to be maintained between claddings and sheathing.
	Foils	50 x 38mm battens. Allow a minimum of 50mm ventilated space behind the back of all cladding installations.
	Celutex	25 x 38mm battens. Allow a minimum of 25mm ventilated air space behind the back of all cladding installations.

General		
Installation Temperature		To be installed between 5°C & 25°C temperatures

Fire Rating				
	Range	Finish	Thickness (mm)	Class
BS476 Part 7	Roofline	White	16 - 25	1
BS476 Part 7	Roofline	White	9, 10	1Y
BS476 Part 7	Cladding	White	6	1Y
BS476 Part 7	Cladding	White / Coloured	7	2Y
EUROCLASS BS EN 13823 & BS EN ISO 11925-2	Cladding	White / Coloured	6, 7	D-s3,d2



This document is printed on environmentally friendly paper



Customer Services

For further enquiries or to place your orders please contact:

Tel: 08705 920930
Fax: 08700 720930

Estimating Department

Celuform, Suite 20, 70 Churchill Square, Kings Hill, West Malling, Kent ME19 4YU

Tel: 01732 897791
Fax: 01732 897795

Technical Department

Email: info@celuform.co.uk

Web site: www.celuform.co.uk

