

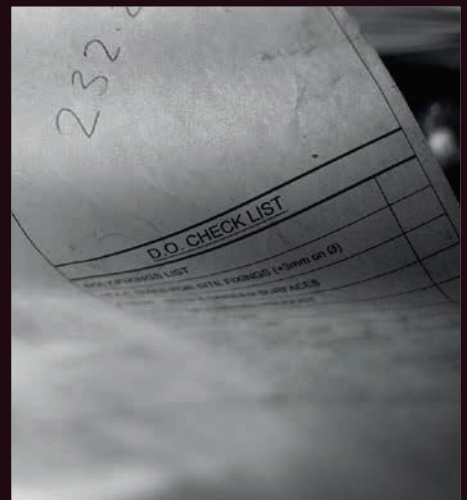

CANAL

www.canal.eu.com

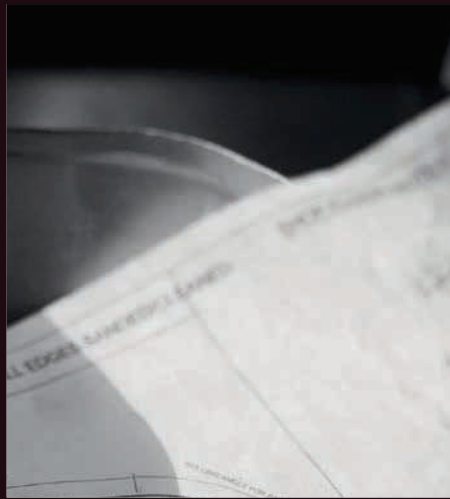

| ARCHITECTURAL METALWORK



I am proud to introduce you to a selection of stunning architectural metalwork projects designed, engineered, manufactured and installed by the skilled and expert team here at Canal Engineering.

When it comes to transforming contemporary design ideas into metalwork structures; architects and specifiers choose us as their partner for British made, bespoke architectural metalwork because we have all the knowledge and engineering expertise required.

Working with us and our own engineering drawing office in Nottingham we will contribute to your design process; ensuring the result is magnificent, as well as structurally sound and compliant with building regulations.

Once under construction, the team will use its portfolio of quality suppliers to source all materials required, undertake the project management and communicate progress at every step of the journey. Visit our workshop and you'll see for yourself the transition from drawing to structure that truly demonstrates the expertise that is CANAL Architectural.

A handwritten signature in black ink, which appears to read 'M. Price'.

Martin Price
Managing Director

| RESIDENTIAL PROJECTS

Modern homes with their sleek features and stunning good looks demand admiration, so when a design vision presents a structural challenge CANAL Architectural is the perfect contract partner.

We have worked with home owners, developers, architects and designers to produce this portfolio of bold, unique and enviable staircases and balustrades that form the heart of many contemporary homes and buildings; with their permission, we are now able to share them with you.

FEAT



URE



PROJECT |
VILLAISE
LOCATION |
JERSEY
FABRICATION |
STAIRCASE &
SCULPTURE

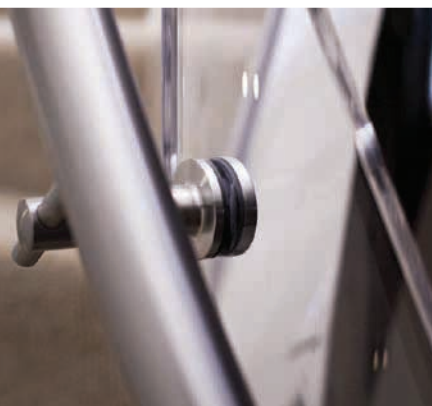
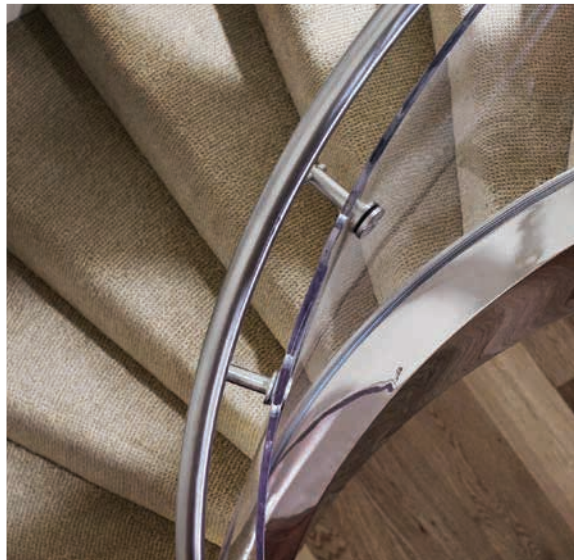

In simple terms, the Villaise staircase is a helical built up the inside of a turret, the outer stringer is fixed to a semi-circular wall, and then plastered over, making it invisible. The inner stringer is a helical stainless steel box section; ribbon fabricated using individual plates. The plate sections were laser cut, rolled then fully welded together before being mirror

polished and installed.

For added impact and artistic effect, the helical ribbon continues past the top of the stair, passing through a cut-out in the acrylic balustrade panel and then tapers to a point creating a sculptural piece of art.

| MATERIALS

HIDDEN MILD STEEL

POLISHED STAINLESS STEEL

ACRYLIC PANELS



| You really need to see this stunning staircase creation to fully appreciate its form as a work of art.

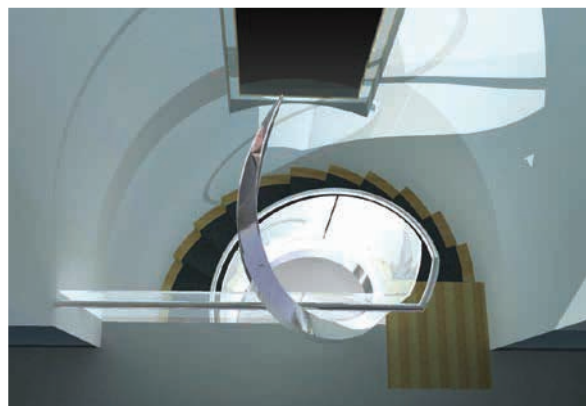
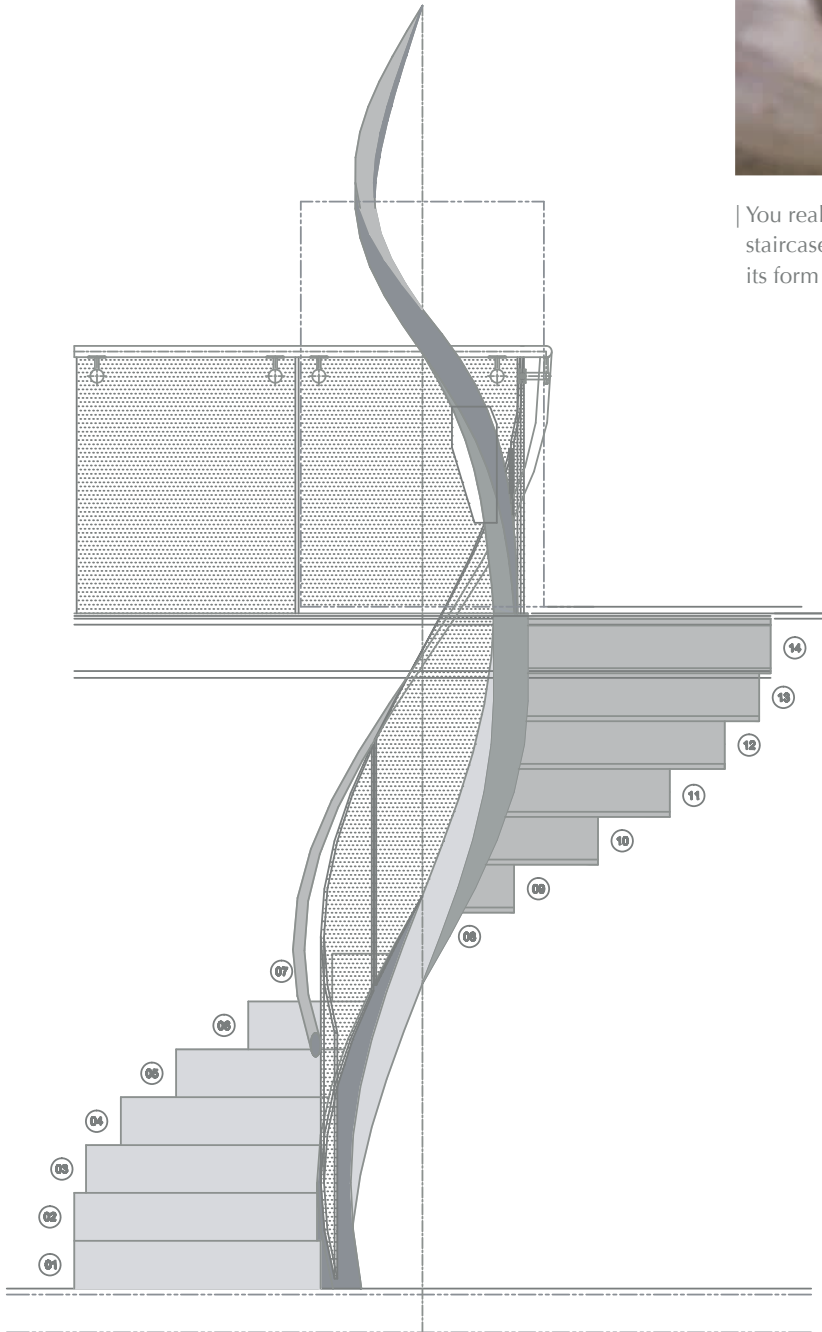

PROJECT |
PIPIN
LOCATION |
BIRMINGHAM
FABRICATION |
TWIN STAIRCASE

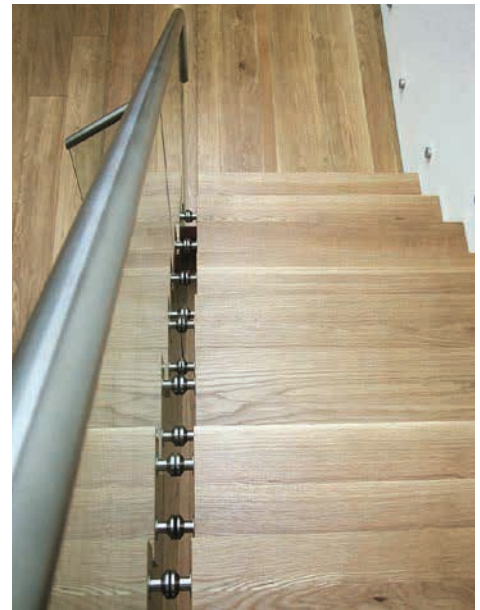

The Pipin cantilever staircase is adaptable for many environments.

The secret to this staircase's success is in hidden cantilever metalwork. The first fix involved embedding a structural steel stringer into the wall with protruding, welded cantilever steel channels. The stringer was then sandwiched behind

a supporting wall and plastered, completely hiding the stringer: Beautifully formed timber box treads were then sleeved over the channels.

Finishing touches included stainless steel bosses affixing the glass balustrade panels to the treads and a complementary satin polished stainless steel slotted tubular handrail.

| MATERIALS

HIDDEN MILD STEEL

STAINLESS STEEL

TIMBER

15MM TOUGHENED GLASS

SCOPE





EX

PROJECT |
 CLIFF
 LOCATION |
 JERSEY
 FABRICATION |
 INTERIOR &
 EXTERIOR
 BALUSTRADE



PAND



Making the most of the stunning sea views from the full height windows on all floors, each exterior balcony has toughened frameless glass balustrades running the full width of the house finished with side fixed mirror polished grade 316 stainless steel handrails.

Continuing inside to retain the sense of light and space, the interior staircases and balustrades were also created using toughened frameless glass with satin polished stainless steel handrails.

| MATERIALS

MIRROR POLISHED STAINLESS STEEL

SATIN POLISHED STAINLESS STEEL

15MM TOUGHENED GLASS

PROJECT |
STORMONT
LOCATION |
LONDON
FABRICATION |
MULTI-FLOOR
STAIRCASE



STRUCT

The simple lines dominate the overall effect of this four-flight staircase rising from the open-plan ground floor of this stunning family house.

To achieve the simplicity the design demanded, the staircase has been manufactured using laser-cut profiled steel stringers,

combined with suspended half-landings, and then finished with European oak. Cleverly, the glass balustrade has been mechanically fixed to the stringer then cloaked with a rebated/mitred oak fascia.

| MATERIALS

LASER CUT STEEL

TOUGHENED GLASS

EUROPEAN OAK





URE



DISTINCTION

PROJECT | MEAT FACTORY
LOCATION | NOTTINGHAM
FABRICATION | STAIRCASE & BRIDGE



Photos: Hannah Marsh



This low-energy home has been recognised for its architectural excellence by both the Royal Institute of British Architects (RIBA) and the Civic Trust. The eco-credentials of the build meant CANAL used many different steel sections and plates which had very different raw finishes. The finished

staircase and bridge had to look totally uniform and naturally rusty; presenting a very difficult engineering and fabrication challenge. With time on their side, a combination of natural weathering, artificial weathering and lacquering achieved the desired effect.

"I chose CANAL to fabricate the stair and gallery bridge because of their ability to precision fabricate and install within a complex and awkward geometry."

**Professor Julian Marsh MA Dip.
Arch RIBA FRSA**

| MATERIALS

LACQUERED STEEL

FROSTED GLASS

PROJECT |
MOLE HILL
LOCATION |
SOUTH LONDON
FABRICATION |
EXTERIOR
STAIRCASE &
BALUSTRADE

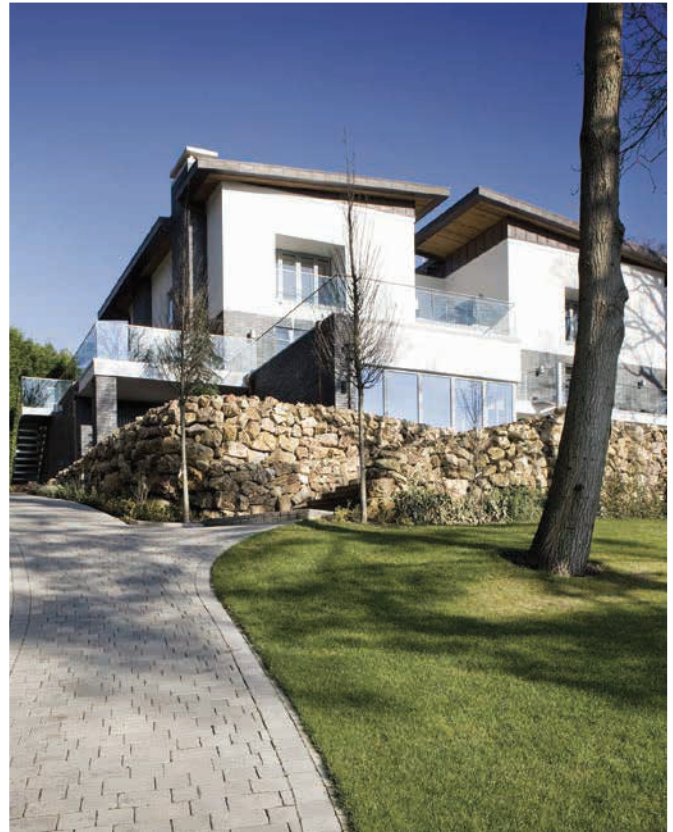

This large contemporary home in Surrey wished to retain uninterrupted views of the garden from the first floor balcony and rooms. The seemingly simple, clean lines of the design meant the quality of the drawings, close attention to every detail and excellent communication between CANAL, the main contractor,

Octagon Developments, and the client were critical to the overall success of the project.

A simple slotted stainless steel handrail atop 15mm toughened glass panels fitted the bill perfectly: Complementing the house and landscape and making a lasting impression.

| MATERIALS

SLOTTED STAINLESS STEEL

15MM TOUGHENED GLASS

STREN



GTH

BALANCE

| PROJECT / NORTH AUDLEY

As with many projects, design and budget need to balance: This concept design was detailed by the architect and approved by the client, but then required the skills and expertise of the CANAL team to work out how to value engineer it to bring it in on budget.

A pre-manufacture sample showing the connection between glass, timber and steel without any visible fixings was able to satisfy everyone and secure the deal.









PROJECT |
NORTH AUDLEY
LOCATION |
LONDON
FABRICATION |
STAIRCASE

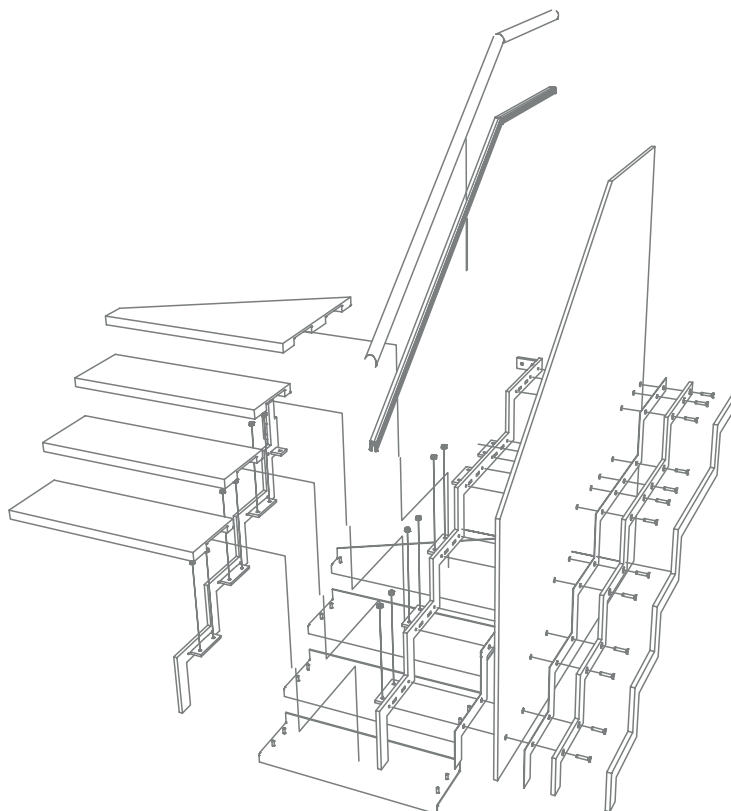

The staircase structure was powder coated mild steel with 15mm toughened low iron glass forming the balustrade. All the treads and handrails were finished in American white oak. Open risers are tricky to accommodate within

building regulations; the solution was to create short steel risers by extending the mild-steel tread carriers, resulting in an unobtrusive framework and providing strength to the structure.

- | MATERIALS
- POWDER COATED MILD STEEL
- 15MM TOUGHENED LOW IRON GLASS
- AMERICAN WHITE OAK



BE

PROJECT |
 BASIN APPROACH
 LOCATION |
 LONDON
 FABRICATION |
 SPIRAL STAIRCASE



SPOKE



When the design calls for a joint free, smooth effect the CANAL installation team take control. All the stainless elements of this spiral stair were manufactured in Nottingham before being delivered in manageable sized component parts to site. Once assembled,

they were fully welded together and polished back to give the continuous ribbon effect passing through the property that was in the brief. To add to the elegance, the treads and balustrades were formed using low iron glass; to give that gin clear look.

| MATERIALS

SATIN POLISHED STAINLESS STEEL

TOUGHENED LOW IRON GLASS

PROJECT |
BUTTERY
LOCATION |
DERBYSHIRE
FABRICATION |
STAIRCASE



In order to leave unobstructed views from the full length glass windows much of the structure of this staircase is in the wall. Lots of glass and what appears to be very little structural support make this staircase a triumph.

With no edging on the treads this staircase appears to float: To complete the illusion, the first floor landing is

edged with a 300mm glass border around the stair void.

The stair is finished with satin polished stainless steel tubular, handrails side fixed from the 15mm structural glass panels.

Offering value engineering; we installed post and infill balustrade using 10mm glass on the landing area and staircase to the second floor.

| MATERIALS

SATIN POLISHED
STAINLESS STEEL

LAMINATED & SANDBLASTED
39MM GLASS

TUBULAR STAINLESS STEEL

TOUGHENED GLASS

ENDUR



ANCE



CONTEMPORARY

PROJECT |
 ENDSLEIGH GARDENS
LOCATION |
 NOTTINGHAM
FABRICATION |
 BALUSTRADE

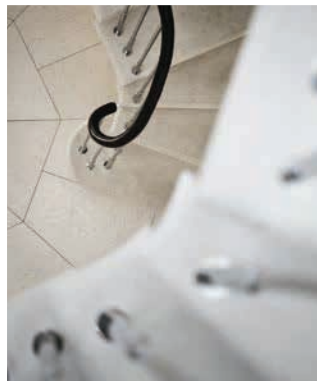

This contemporary home with its helical concrete staircase and mirror polished surroundings deserved a simple but elegant balustrade. CANAL manufactured individual mirror polished stainless steel spindle rods that were staggered to follow

the line of the staircase. The rods were secured into the concrete at different intervals to ensure the symmetry and flow of the staircase through the home. To complete the sense of opulence, the balustrade was topped with a dark brown leather handrail.

| MATERIALS

MIRROR POLISHED
 STAINLESS STEEL

CONCRETE

LEATHER

PROJECT |
MOLE HILL
LOCATION |
SOUTH LONDON
FABRICATION |
STAIRCASE
& ATRIUM
BALUSTRADE



"From the start we found CANAL's approach to what was a complex project; very professional, efficient and attention to detail extremely good. My Client did, on numerous occasions, refer to CANAL as the best contractor working on the project, I would agree."

Mr Rob Stone, Octagon Developments Ltd

PRE

Whilst all the detailing of this contemporary stair and atrium was done by the CANAL drawing team; as on many large projects, many sub-contractors were involved. Good communication and a professional approach were imperative to achieving the overall impact of this fantastic practical intelligent and considered design.

The main stair structure is a stainless steel box section

acting as a centre spine with concrete filled, steel tread carriers, clad in marble. The balustrade is fully fabricated from stainless box sections, creating a harp like effect, and finished with an elliptical timber handrail.

The atrium glass balustrade was constructed from low iron glass with a custom made glass track.

| MATERIALS

STAINLESS STEEL

CONCRETE

MARBLE

TIMBER

LOW IRON GLASS



STIGE



PRO

PROJECT |
 FLORÉAL
 LOCATION |
 JERSEY
 FABRICATION |
 EXTERIOR
 BALUSTRADE



“Where other companies only highlighted problems, CANAL Architectural offered us solutions and in some cases showed us how much further we could take our designs in staircase and handrail design: CANAL is our first port of call when designing bespoke metalwork.”

Mr George De Sousa,
PAGE Architects



MINENCE

This gorgeous house on Jersey is complemented by 17.5mm toughened laminated glass balustrades around the many balconies to make the most of stunning views from the full height windows on all floors.

Each balustrade has an elliptical mirror polished stainless steel handrail running along the top and terminates in the wall to finish the detailing of this transparent masterpiece.

| MATERIALS

17.5MM TOUGHENED,
 LAMINATED GLASS

MIRROR POLISHED ELLIPTICAL
 STAINLESS STEEL

PROJECT |
CARLTON
LOCATION |
JERSEY
FABRICATION |
EXTERIOR
BALUSTRADE



GR



On the site of the former 48 room Carlton Hotel, exclusive apartments now stand.

Antler Homes finished the interiors to the highest possible standard with air conditioning and luxurious kitchens and bathrooms and with each apartment commanding breathtaking sea views from

the generous balconies, the balustrade needed to be something special.

CANAL manufactured large glass and mirror polished stainless steel balustrades for the Art Nouveau and nautical inspired softly curving wrap around balconies.

| MATERIALS

MIRROR POLISHED
STAINLESS STEEL

10MM TOUGHENED GLASS

AND







From concept to completion, our philosophy is based on offering clients the very best technical solution for every project; always making sure the integrity of the original design concept is preserved.

With a heritage of British design innovation, use of the finest materials, quality manufacture to exacting specifications and efficient installation, we have developed an enviable reputation; as demonstrated by our strong and loyal client base both in the UK and abroad.

| COMMERCIAL PROJECTS

Whilst many CANAL projects are for staircases and balustrades, our experience extends to all aspects of architectural metalwork including; canopies, balconies, bespoke railings and sculptures.

On large commercial projects we demonstrate our size and strength; tendering, securing and successfully delivering multi-million pound projects on time and on budget. Time and again the pro-active attitude of the CANAL team secures the confidence of all professionals and contractors.



"CANAL is incredibly helpful, knowledgeable and professional. CANAL would always be our first point of contact for architectural metalwork."

Annette Peters Design Limited

MAGNIFIC



ICENT

PROJECT |
OGIER
LOCATION |
JERSEY
FABRICATION |
STAIRCASE

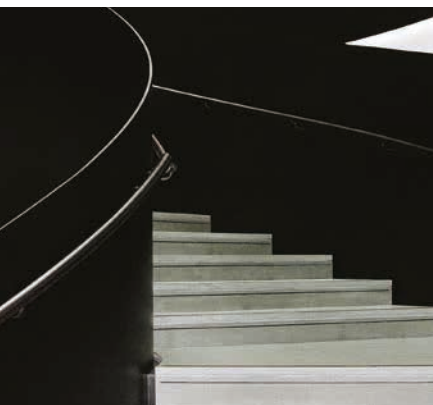

The architects, ORMS of London, set a tough task; their design was for a magnificent helical staircase totally unsupported from below. This incredible staircase is now complete and taking pride of place in the Jersey office of International Corporate and Finance Law company; Ogier.

To get the right combination of gorgeous lines and required strength, the first floor

balustrade and the staircase balustrade were all constructed using 15mm thick steel plate which needed to be fully welded together on site to prevent any defects occurring: This will give you some idea of the enormous task faced by the CANAL installation team.

| MATERIALS

GREY STONE

15MM STEEL PLATE

STAINED OAK

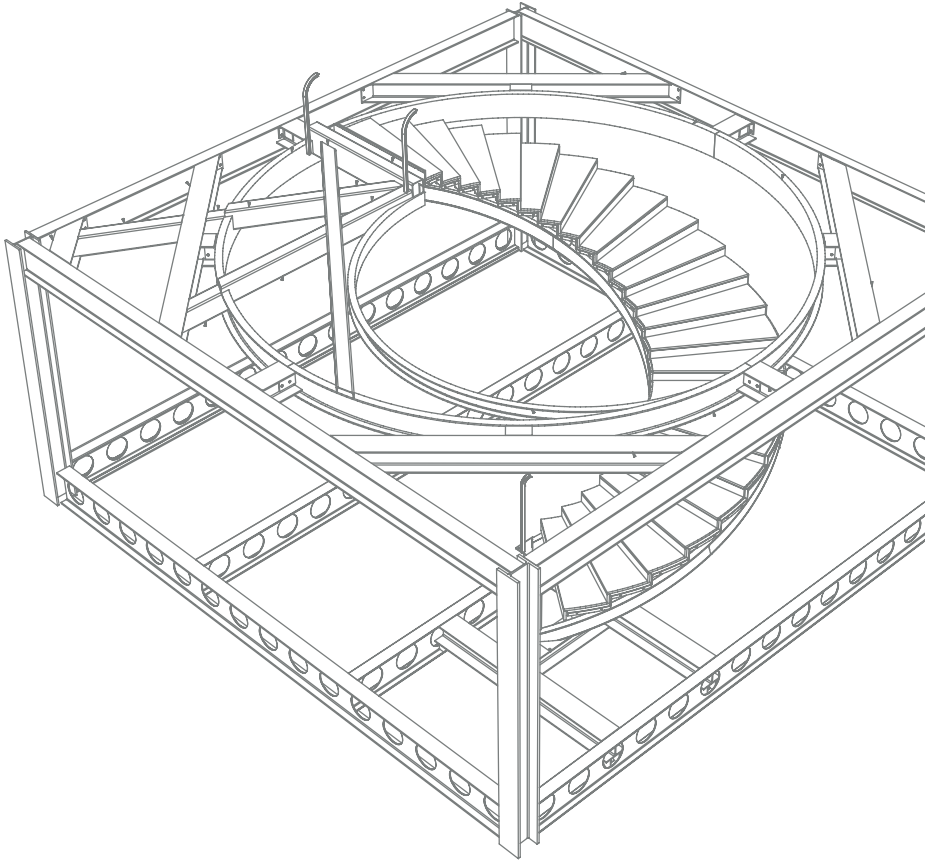
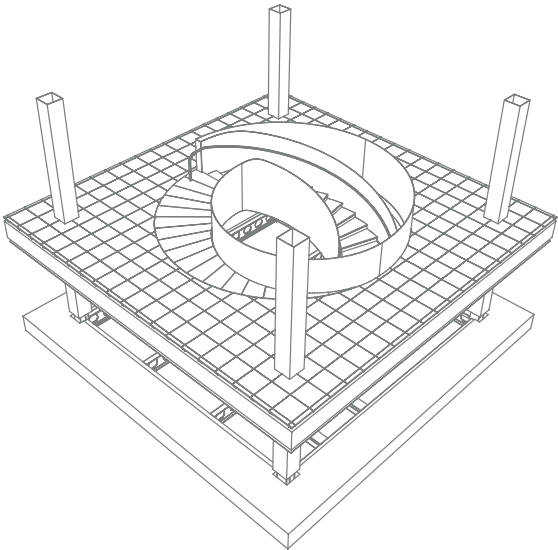

Structurally this was made even more difficult as the atrium it ascended through was a square opening; much bigger than the staircase diameter. Without compromising the integrity of the design the upper floor needed to be decked out with structural steel; creating a circular opening strong enough to support the load of the floating staircase.



AD

PROJECT |
 HARBOURSIDE
 LOCATION |
 BRISTOL
 FABRICATION |
 STAIRCASE &
 ATRIUM
 BALUSTRADE

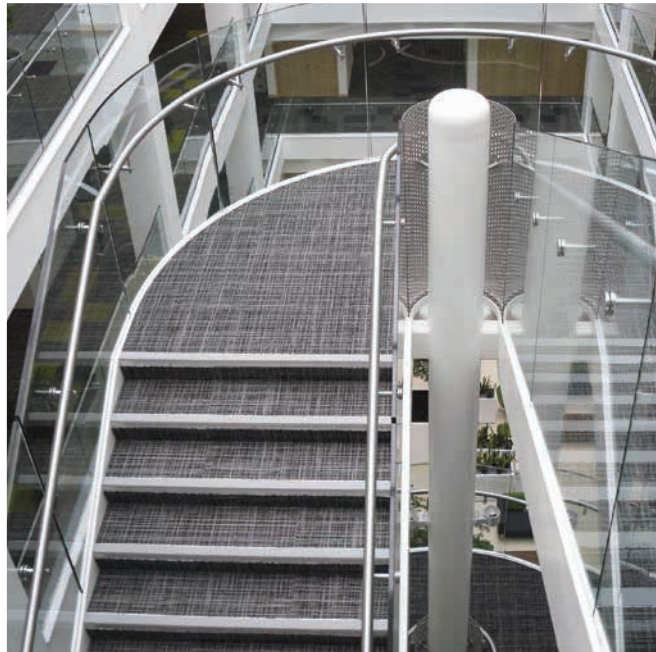

MIRABLE



This four storey balustraded atrium is an impressive feature of the building: Each staircase flight and each semi-circular landing was constructed in a single piece off site and transported to site: The large sections of stairs were then hoisted into position.

Although, logistically, this was a tremendous challenge;

off site construction dramatically reduced the installation time on site. The staircases and atrium balustrades were installed in just two weeks.

CANAL was able to deliver superior quality craftsmanship to a tight deadline within the demands made by the construction.

| MATERIALS

POWDER COATED STEEL

15MM TOUGHENED GLASS

SATIN POLISHED STAINLESS STEEL

IMPRESSIVE

| PROJECT / ARGUS

Securing a contract for a 5m diameter, 4m rise, helical staircase to be installed nearly 5,500km away from our Nottingham workshop in the tallest commercial building on Bermuda was quite a feat; building and installing it was quite another.

Tendering against both British and American metalwork companies our initial success was accomplished with our pro-active attitude to developing the architect's design concepts and our confidence in engineering the structure.







The architect's specification was challenging; other than fixing points at the bottom and top, there was to be no additional structural support. Once installed there was to be no movement or deflection in the staircase.

Once the structural drawings were approved, the CANAL team fabricated the staircase in the works factory and tested it for movement before dismantling it piece by piece, packing it in crates and shipping it the 5,500km to Bermuda.

| MATERIALS

SATIN POLISHED STAINLESS STEEL

316 GRADE STAINLESS STEEL

TOUGHENED GLASS

STONE



PROJECT |
 ARGUS
LOCATION |
 BERMUDA
FABRICATION |
 HELICAL
 STAIRCASE
 & CANOPY

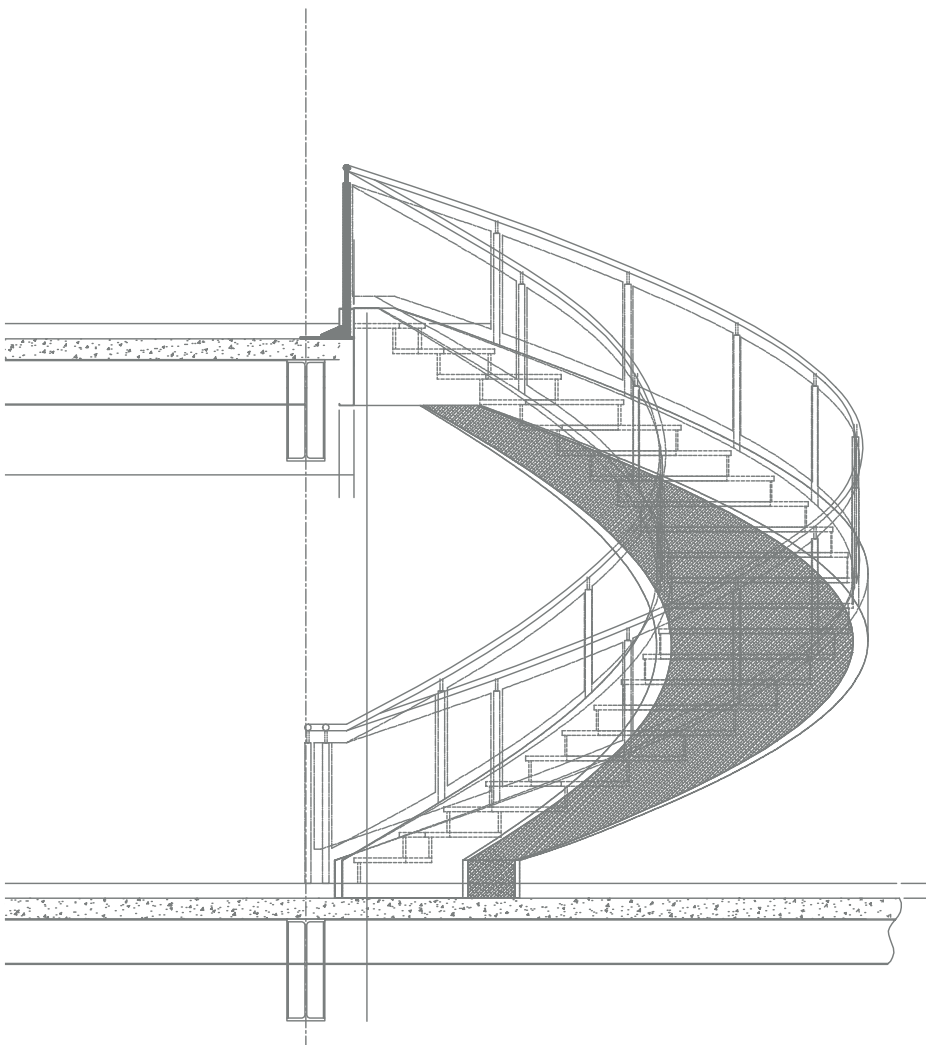

On site, the CANAL team had no time to enjoy the Bermudan sun, as piece by piece they reconstructed the feature staircase, welded it all in place to create the seamless masterpiece. Whilst there, they also installed the 35 metre high stainless steel canopy and etched glass doors for the main entrance too.





STATE

PROJECT |
DOMUS
LOCATION |
LONDON
FABRICATION |
STAIRCASE

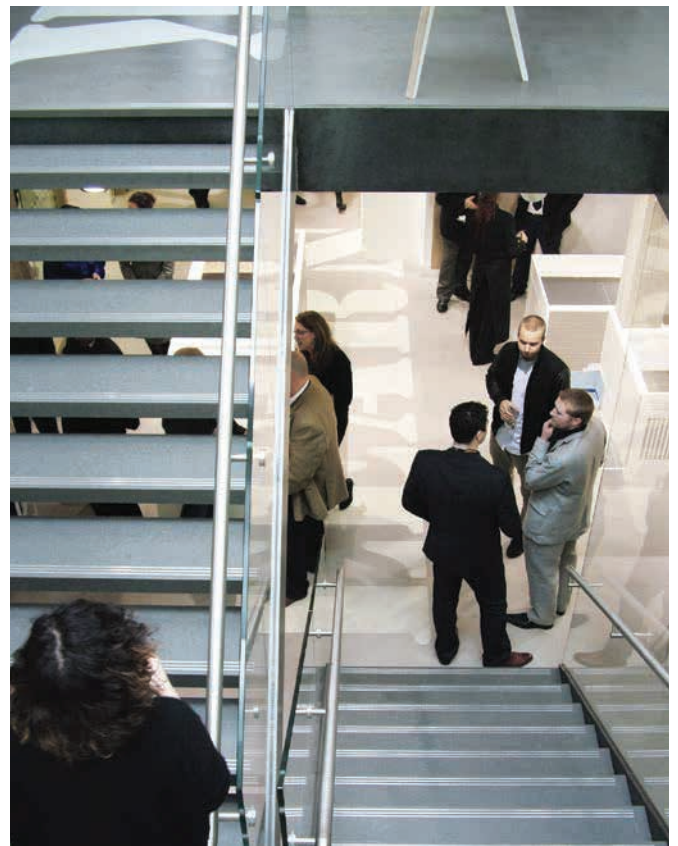

MENT



For their new showroom in London, tile company Domus wanted to create a space where architects and designers could meet and feel comfortable.

Complementing the natural look and textures of many of their tiles the staircase was

designed to have an organic feel. Appearing to be a structure supported by a glass box, the mild steel work was subject to laser cutting, welding and sanding that would oxidise over time to achieve the desired effect.

| MATERIALS

MILD STEEL

TOUGHENED LOW IRON GLASS

STAINLESS STEEL

PROJECT |
HENRIETTA HOUSE
LOCATION |
LONDON
FABRICATION |
STAIRCASE &
BALUSTRADE

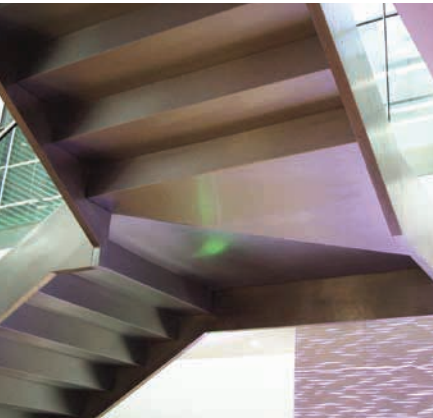

A prestigious, seven storey office redevelopment in London's West End to create a new headquarters for CB Richard Ellis. To create very clean lines and to reduce the weight of the structure all the main structural elements of this staircase are formed in mild steel. The tread carriers are concrete filled, formed mild steel cloaked in thin gauge stainless pressings.

| MATERIALS

MILD STEEL

CONCRETE

STAINLESS STEEL FACINGS

CURVED GLASS PANELS

TOUGHENED GLASS

IMPRES



SION

PROJECT |
GATWICK
LOCATION |
LONDON
FABRICATION |
BALUSTRADE

TOUGH



CANAL is often tasked with producing bespoke architectural metalwork incorporating glass on a large scale for commercial projects. Having previously produced bespoke architectural metalwork for BAA the reputation of CANAL secured the contract for the expansion of Gatwick's North Terminal; supplying 500 metres of balustrade using 20mm thick mild steel balusters, laminated

glass, all finished with satin polished hand and trolley rails.

The simple, clean balustrade design breaks up the industrial airport ambience by de-cluttering and allowing engagement with the surrounding greenery: Meeting all important control and security requirements and making a modern entrance.

| MATERIALS

LAMINATED GLASS

SATIN POLISHED STAINLESS STEEL

20MM MILD STEEL

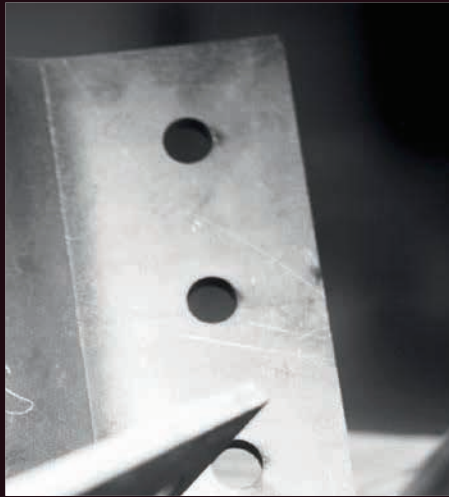

From concept to completion, our philosophy is based on offering clients the very best technical solution for every project; always making sure the integrity of the original design concept is preserved.

CONCEPT

Our heritage is in steel, but today we work with many modern metals and other materials to realise the possibilities of a design idea: Your vision translated to materials and structure seamlessly.

DESIGN DEVELOPMENT

To aid your design process our structural calculations and engineering drawings will ensure the result is magnificent, as well as structurally sound and compliant with building regulations.

MANUFACTURE

Visit our workshop and you'll see for yourself the transition from drawing to structure that truly demonstrates the expertise that is CANAL Architectural.

INSTALLATION

Once under construction, CANAL will undertake project management, liaise with other sub-contractors and communicate progress at every step of the journey.

COMPLETION

Our portfolio would be nothing without the support and cooperation of architects, developers and clients for whom project completion is when they are 100% satisfied with their architectural metalwork project.

SET US YOUR CHALLENGE

If your heart is set on your design vision, turn to CANAL; we use our heads to create bold, unique and enviable architectural metalwork that is expertly engineered in Britain:

Contact our technical sales team; 0115 986 6321,
canal@canalengineering.co.uk.



| By Canal Engineering Limited

Tel: 0115 986 6321 www.canal.eu.com

Lenton Lane, Nottingham. NG7 2PQ