

AUTOMATION FOR SWING GATES

FERNI
SERIES



INSTALLATION MANUAL

FE4024

Legend of symbols	p. 4
Intended use and limits	p. 4
Intended use	p. 4
Limits to use	p. 4
Description	p. 4
Technical features	p. 4
Description of the parts	p. 5
Dimensions	p. 5
Installation	p. 6
Preliminary checks	p. 6
Tools and materials	p. 6
Cable list and minimum thickness	p. 6
Standard installation	p. 7
Preparing the corrugated tubing and the anchoring brackets	p. 7
Installing the gearmotor and the transmission arms	p. 10
Securing and adjusting the endstop unit for the LEFT gearmotor	p. 12
Securing and adjusting the endstop unit for the RIGHT gearmotor	p. 13
Securing the covers and the release handles	p. 14
Manual release and locking of the gearmotor	p. 15
Connecting to the control panel	p. 16
Safety instructions	p. 17
Maintenance	p. 18
Trouble shooting	p. 18
Periodic maintenance	p. 18
Extra-ordinary maintenance	p. 19
Phasing out and disposal	p. 20
CE declaration	p. 21

WARNING!

Important instructions for the safety of people: READ CAREFULLY!



Foreword

• Use of the products must be restricted to its intended use (i.e. that for which it was expressly built for). Any other use is to be considered dangerous. Came Cancelli Automatici S.p.A. is not liable for any damage resulting from improper, wrongful or unreasonable use • Keep these warnings with the installation and use manuals issued with the automated system.

Before installing

(preliminary check: in case of a negative outcome, do not proceed before having complied with the safety obligations)

• Make sure that the parts you intend to automate are in good working order, and that they are properly balanced and aligned. Also, make sure that proper mechanical stops are already in place • If the operator will be installed at a height of less than 2.5 m from the ground or other access level, check whether you will need any protections and/or warnings • Any gate leaves, fitted with pedestrian entrances, onto which you will install an operator, must have a blocking mechanism when the gate is in motion • Make sure that the opening of the automated gate is not an entrapment hazard as regards any surrounding fixed parts • Do not mount the operator upside down or onto any elements that may fold under its weight. If needed, add suitable reinforcements at the points where it is secured • Do not install onto gates on either an upward or downward slope (i.e. that are not on flat, level ground) • Check that any lawn watering devices will not wet the gearmotor from the bottom up.

Installation

• Carefully section off the entire site to prevent unauthorised access, especially by minors and children • Be careful when handling operators that weigh more than 20 Kg (see installation manual). In such cases, employ proper weight handling safety equipment • All opening commands (e.g. buttons, key selectors, magnetic detectors, etc.) must be installed at least 1.85 m from the gate's area of operation perimeter - or where they cannot be reached from the outside of the gate. Also, the direct commands (e.g. push button, or proximity devices, etc.) must be installed at a height of at least 1.5 m and must not be accessible to the public • All 'maintained action' commands, must be placed where the moving gate leaves, transit areas and driveways are completely visible • If missing, apply a permanent label that shows the position of the release mechanism • Before delivering to the client, verify that the system is EN 12453 (impact test) standard compliant. Make sure that the operator has been properly adjusted and that the safety and protection devices, as well as the manual release

are working properly • Where necessary and in plain sight, apply the Warning Signs (e.g. gate plate).

Special instructions and advice for users

• Keep the gate's area of operation clean and clear of any obstacles. Trim any vegetation that may interfere with the photocells • Do not allow children to play with the fixed command devices, or in the gate's area of operation. Keep any remote control devices (i.e. transmitters) away from the children as well • Frequently check the system, to see whether any anomalies or signs of wear and tear appear on the moving parts, on the component parts, on the securing points, on the cables and any accessible connections. Keep any joints (i.e. hinges) lubricated and clean, and do the same where friction may occur (i.e. slide rails) • Perform functional tests on photocells and sensitive edges, every six months. Keep glass panels constantly clean (use a slightly water-moistened cloth; do not use solvents or any other chemical products) • If the system requires repairs or modifications, release the operator and do not use it until safety conditions have been restored • Cut off the power supply before releasing the operator for manual openings. See instructions • Users are FORBIDDEN to carry out ANY ACTIONS THAT THEY HAVE NOT BEEN EXPRESSLY ASKED TO DO OR SO INDICATED in the manuals. Any repairs, modifications to the settings and extraordinary maintenance MUST BE DONE BY THE TECHNICAL ASSISTANCE STAFF • On the periodic maintenance log, note down the checks you have done.

Special instructions and advice for all

• Avoid working near the hinges or moving mechanical parts • Stay clear of the gate's area of operation when in motion • Do not resist the direction of movement of the gate; this may present a safety hazard • At all times be extremely careful about dangerous points that must be indicated by proper pictograms and/or black and yellow stripes • When using a selector or command in 'maintained action' mode, keep checking that there are no people in the area of operation of the moving parts. Do this until you release the command • The gate may move at any time without warning • Always cut the power when cleaning performing maintenance.

Legend of symbols



This symbol tells you to read the section with particular care.



This symbol tells you that the sections concern safety issues.



This symbol tells you what to say to the end-users.

Intended use and limits

Intended use

The 001FE4024 operator is engineered and manufactured by CAME Cancelli Automatici S.p.A., in compliance with current safety regulations, to automate swing gates for residential or apartment-block use.



The installation and use of this product for purposes other than those described in this manual are prohibited.

Limits to use

Limits to use of operator with articulated arm and max. 90° gate-leaf opening:

Gate-leaf width (m)	2.00	2.50	3.00	3.50	4.00
Gate-leaf weight (Kg)	800	600	500	450	400

Important: with gate-leaves wider than 2.50 m it is necessary the use of an electric lock.

Limits to use of operator with straight arm and max. 90° gate-leaf opening:

Gate-leaf width (m)	1.50	2.00	2.50
Gate-leaf weight (Kg)	550	500	300

Important: it is necessary to have an electric lock.

Description

The operator is composed of a die-cast aluminium casing. Inside the casing there is an endless screw and helical crown reduction system. Permanent fluid grease lubrication.

Technical features

Control panel power supply: 230 V AC 50/60 Hz

Motor power supply: 24 V DC

Max. draw: 7 A

Power: 130 W

Max. torque: 360 Nm

Duty cycle: intensive duty

Protection rating: IP44

Weight: 12.60 Kg

Insulation class: I

90° opening time: adjustable



Description of the parts

- 1) Pillar bracket
- 2) Endstop
- 3) Gearmotor
- 4) Side supports
- 5) Cover
- 6) Side cover
- 7) Transmission arm
- 8) Driven arm
- 9) Gate bracket
- 10) Release handle
- 11) Straight arm with guide (see technical sheet for mounting procedure)

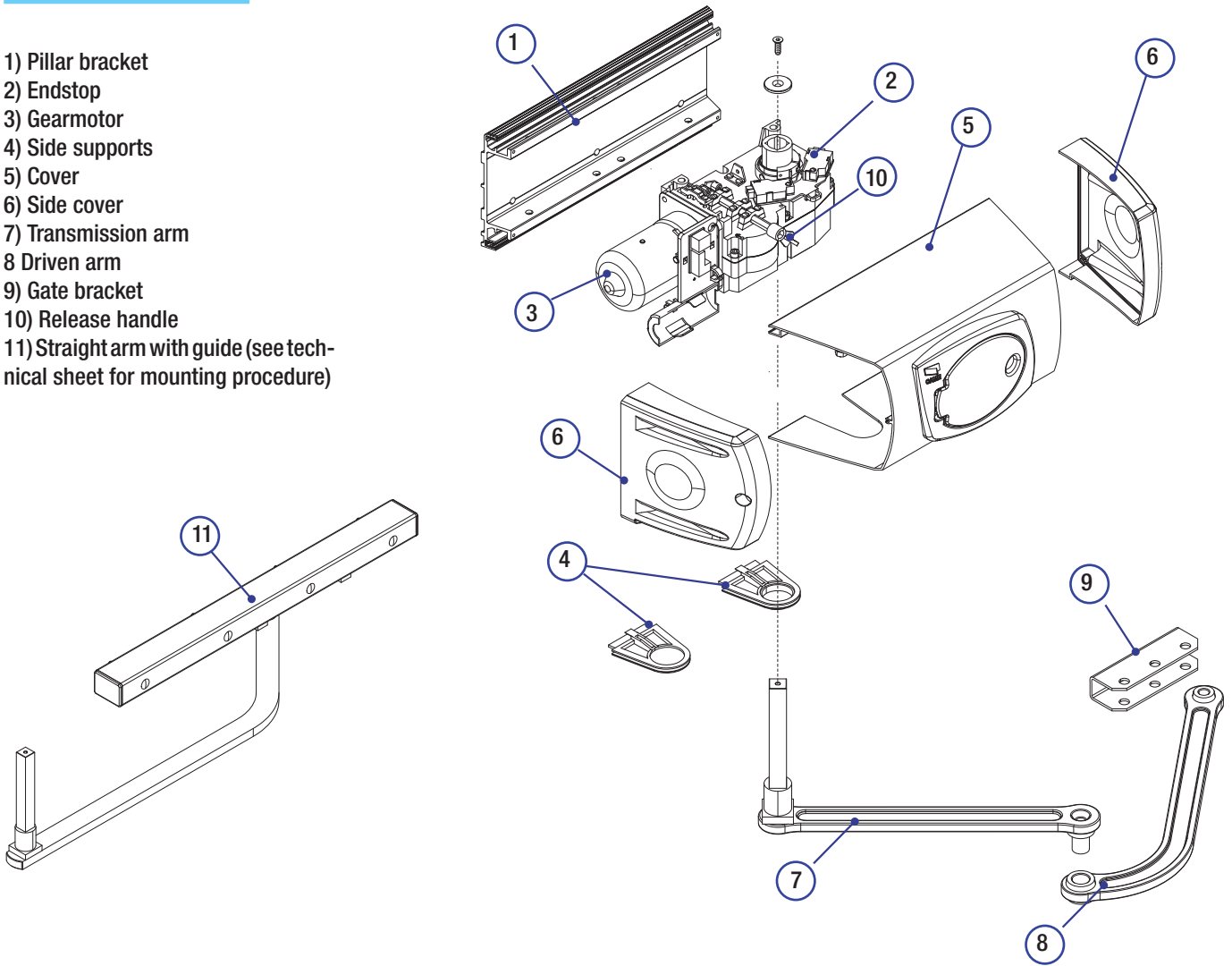

Dimensions

mm

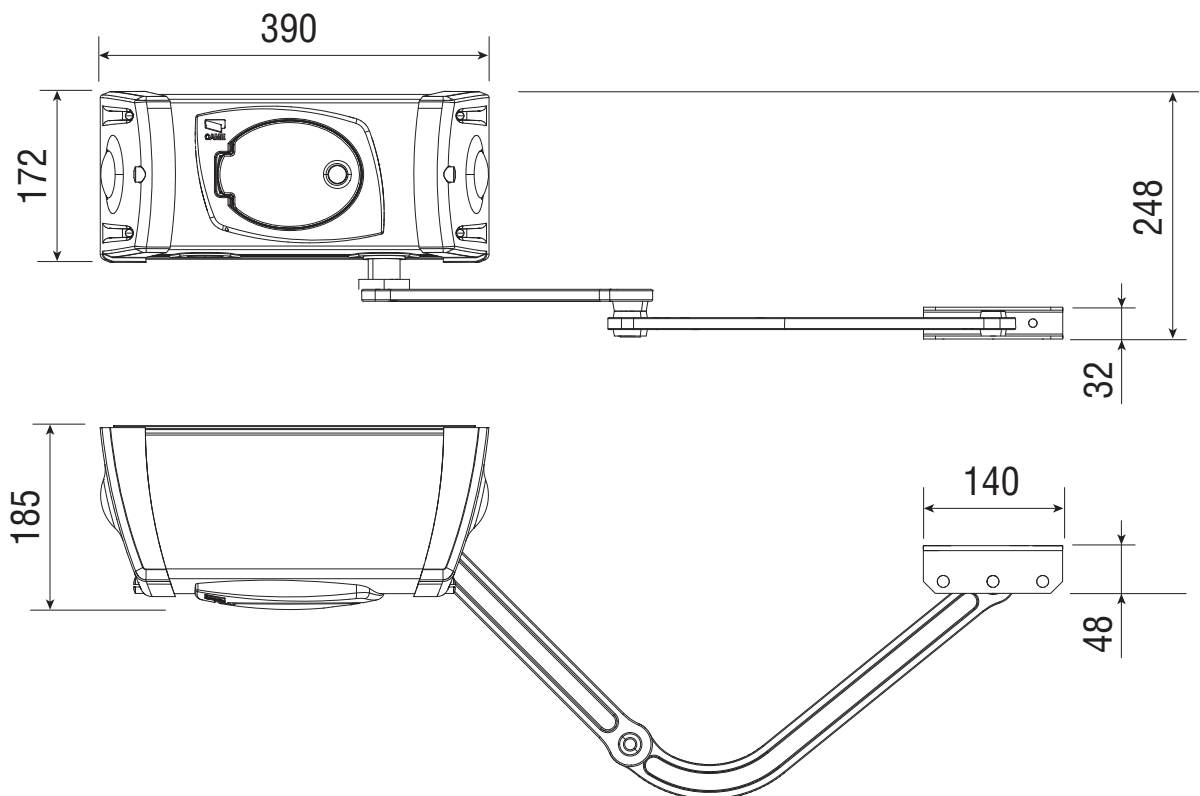

Installation

 Installation must be carried out by expert qualified personnel and in full compliance with current regulations.

Preliminary checks

 Before installing, do the following:

- Make sure you have a suitable omnipolar cut-off device with contacts more than 3 mm apart, and independent (sectioned off) power supply;
- Make sure you have suitable tubing and conduits for the electrical cables to pass through and be protected against mechanical damage;
- Make sure that any connections inside the case (that provide continuance to the protective circuit) be fitted with extra insulation as compared to the other conductive parts inside;
- Make sure the structure of the gate is sturdy, the hinges work and that there is no friction between moving and non-moving parts;
- Make sure there is a mechanical stop for opening and closing.

Tools and materials

Make sure you have all the tools and materials you need for the installation at hand to work in total safety and compliance with the current standards and regulations. The following figure illustrates an example of equipment needed by the installer.

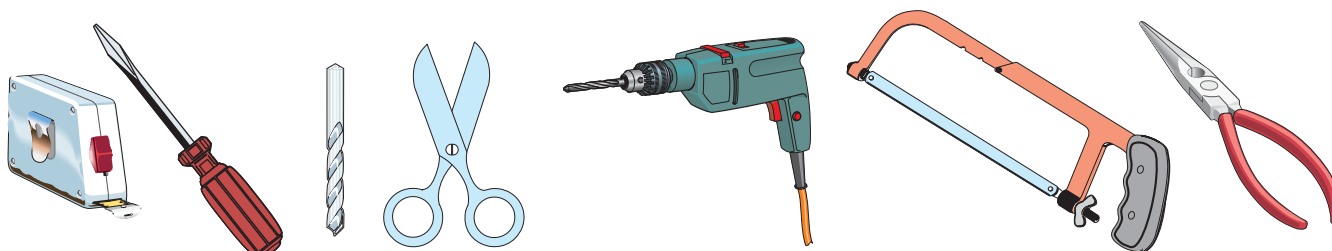

Cable list and minimum thickness

Connection	Type of cable	Cable length 1 < 10 m	Cable length 10 < 20 m	Cable length 20 < 30 m
230 V control panel power supply	FROR CEI 20-22 CEI EN 50267-2-1	3G x 1.5 mm ²	3G x 1.5 mm ²	3G x 2.5 mm ²
24 V motor power supply		2G x 1.5 mm ²	2G x 1.5 mm ²	2G x 2.5 mm ²
Flashing light		2 x 1.5 mm ²	2 x 1.5 mm ²	2 x 1.5 mm ²
Photocell transmitters		2 x 0.5 mm ²	2 x 0.5 mm ²	2 x 0.5 mm ²
Photocell receivers		4 x 1.5 mm ²	4 x 1.5 mm ²	4 x 1.5 mm ²
Accessories power supply		2 x 0.5 mm ²	2 x 0.5 mm ²	2 x 1 mm ²
Command and safety devices		2 x 0.5 mm ²	2 x 0.5 mm ²	2 x 0.5 mm ²
Antenna connection	RG58	max. 10 m		
Encoder connection	TWISTED	max. 30 m		

N.B.: If the cable length differs from that specified in the table, then you must determine the proper cable diameter in the basis of the actual power drawn by the connected devices and depending on the standards specified in CEI EN 60204-1.

For connections that require several, sequential loads, the sizes given on the table must be re-evaluated based on actual power draw and distances. When connecting products that are not specified in this manual, please follow the documentation provided with said products.

Standard installation

- 1) 001FE4024 operator
- 2) Control panel
- 3) Junction box
- 4) Antenna
- 5) Flashing light
- 6) Key-switch selector
- 7) Photocells
- 8) Junction pit
- 9) Electric lock
- 10) Mechanical stops
- 11) Photocell post

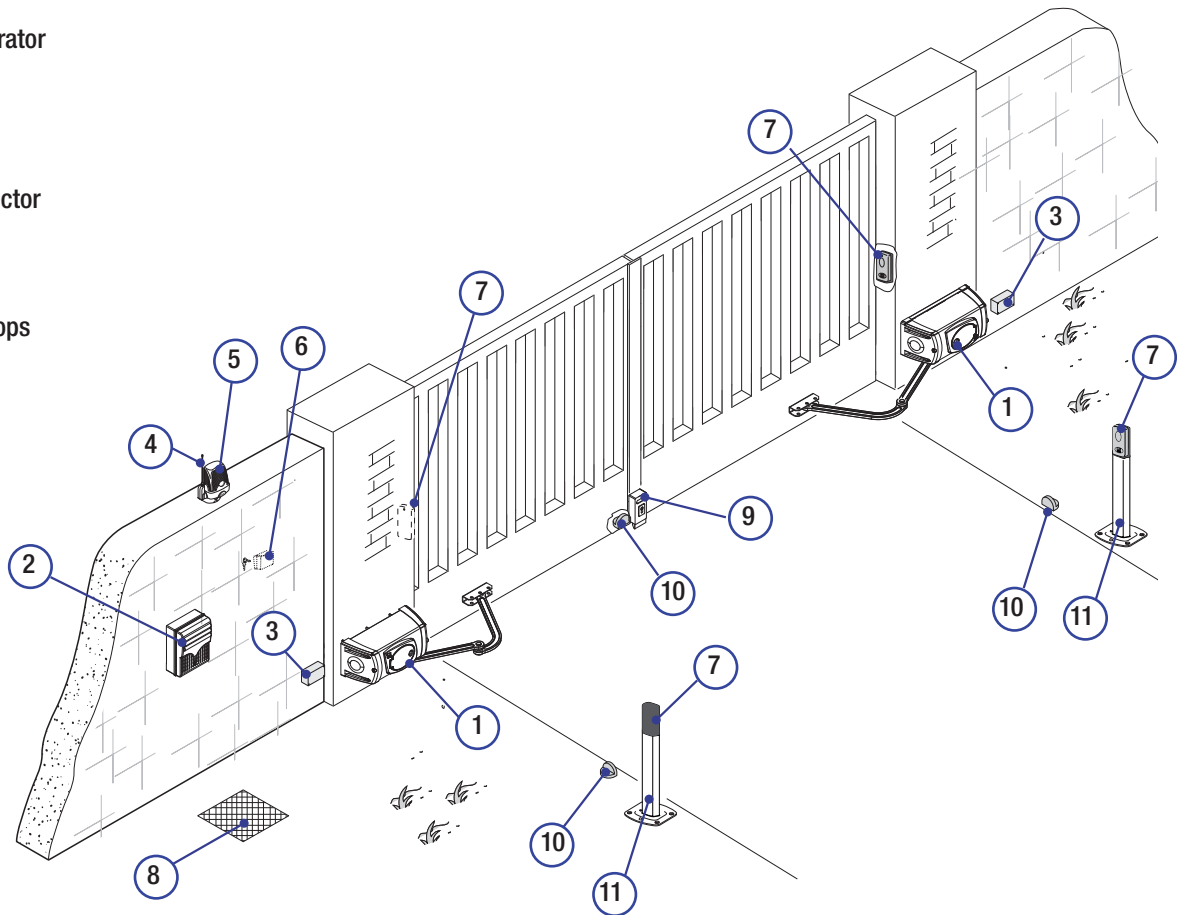

ENGLISH

Preparing the corrugated tubing and the securing brackets



The following figures are only examples, since the room necessary for fixing the automation and the accessories depend on the dimensions. It is therefore up to the installer the choice of the most suitable solution.

Set up the corrugated tubes for connections coming from the junction pit.

N.B.: the tubing depends on the type of installation and on the accessories considered.

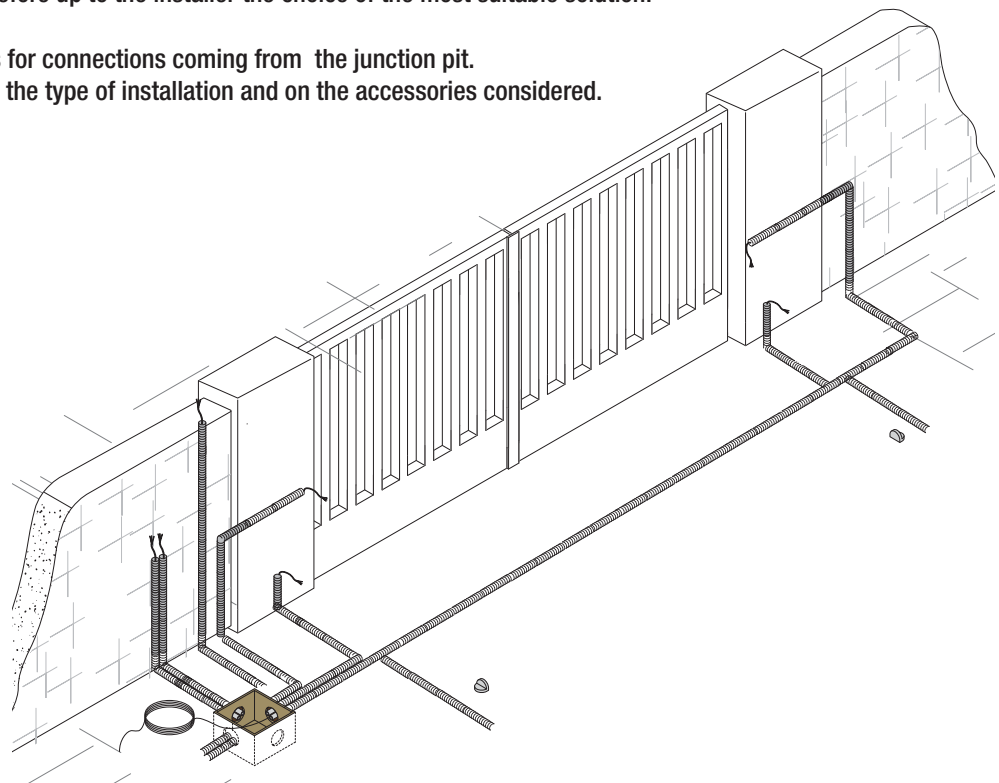

Note: figures refer to the installation of the left gearmotor. The installation of the right gearmotor is symmetrical.
 Respect dimensions indicated in the drawing and determine the most appropriate fixing point for the gate bracket.

ENGLISH

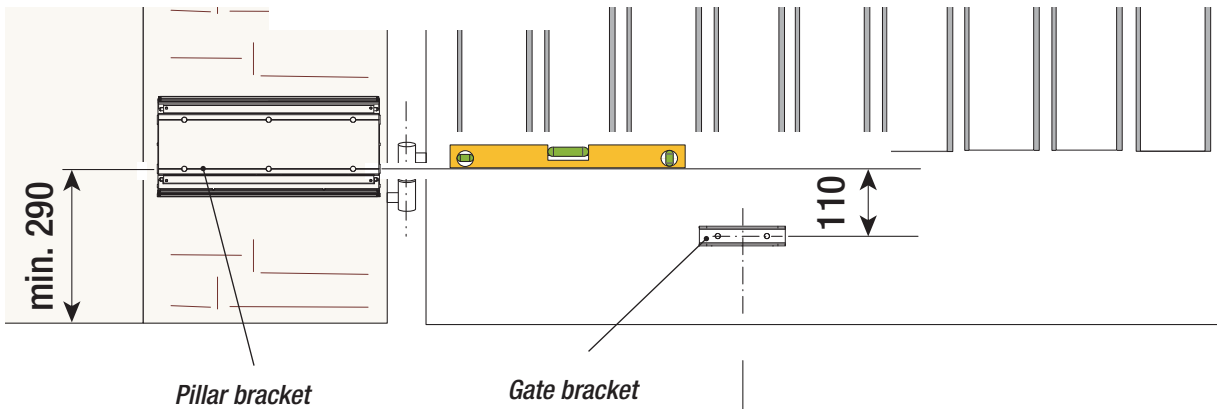

A (mm)	B (mm)
110	0 ÷ 300
150	300 ÷ 380

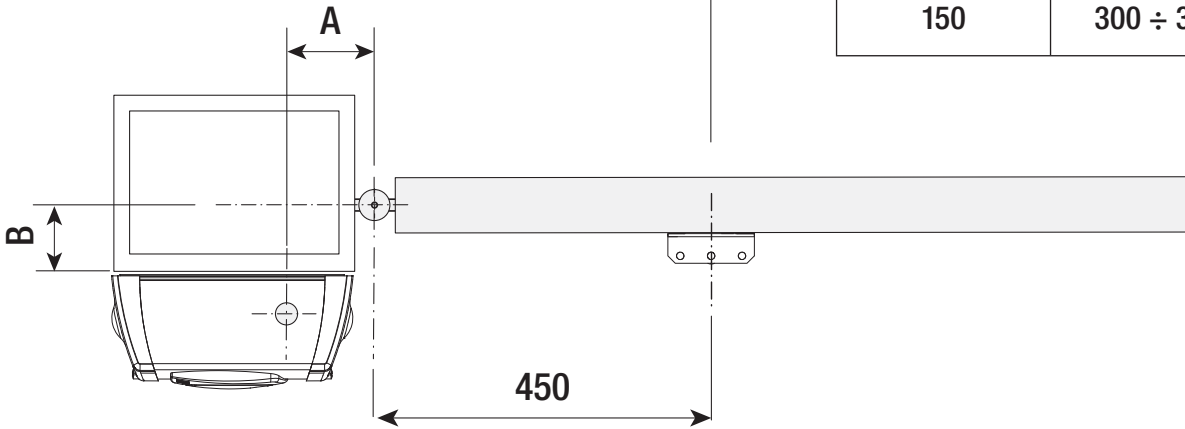

Mark the fixing points for both the pillar and gate brackets, respecting dimensions indicated in the drawing.

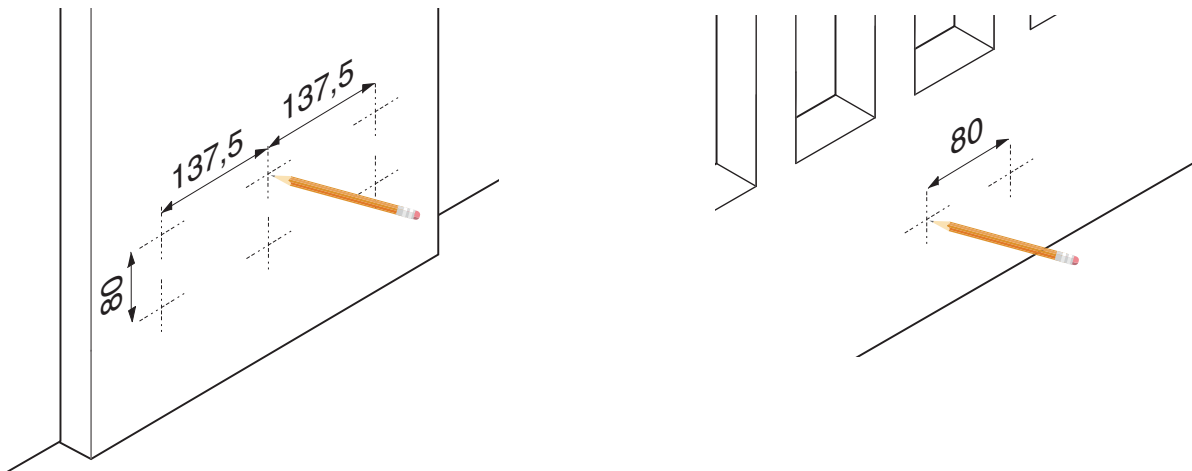

Drill on the marked points.

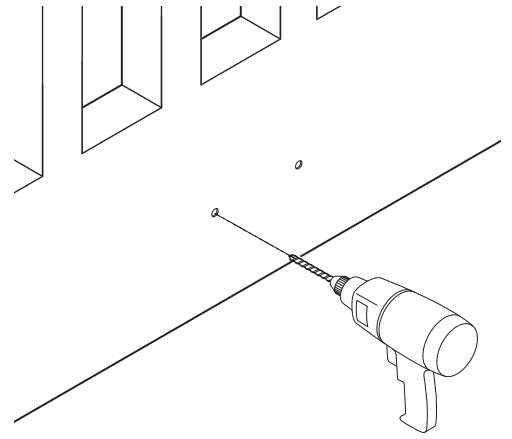
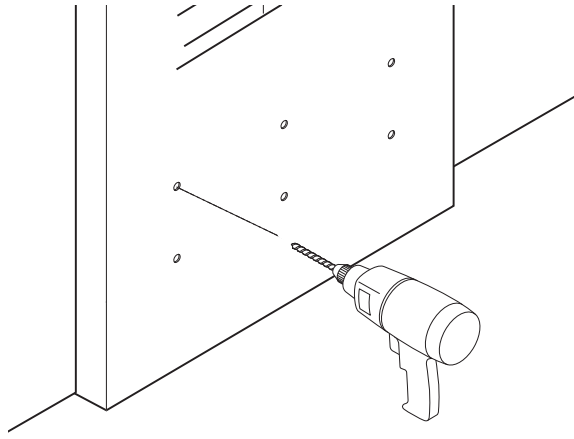

ENGLISH

Insert the dowel or use other inserts suitable for the bracket resistance.

Note: figures are only examples, it is up to the installer the choice of the most suitable solution depending on the type and dimensions of the gate-leaf.

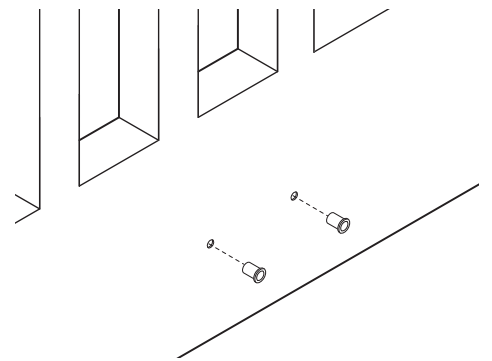
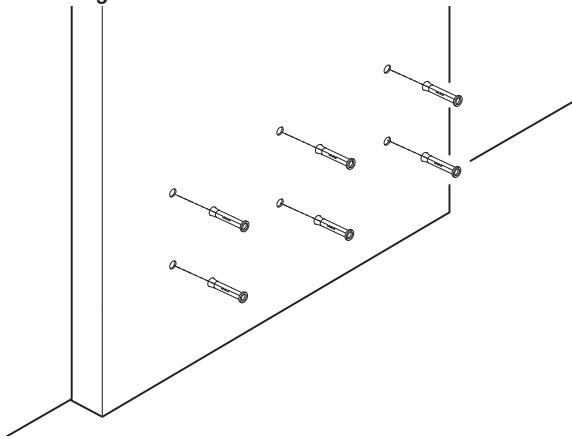

Place the brackets as indicated in the figure and fix them.

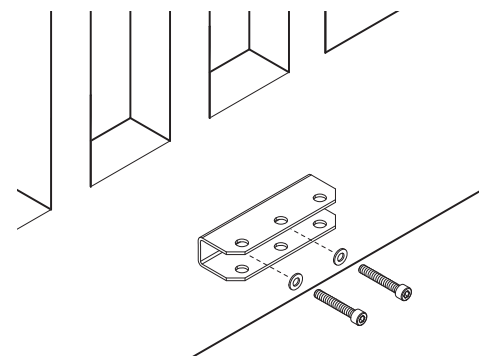
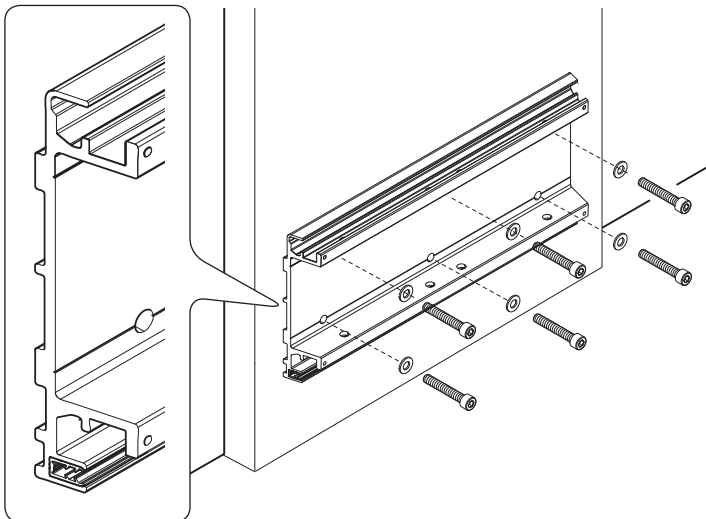

Installing of the gearmotor and the transmission arms

Insert the side supports in the insert places on the pillar bracket. One of the two lateral inserts is for the power cable to go through, the other is for the gearmotor arm to go through.

Note: before inserting the support for the cable passage on the bracket, fix a cable gland on it; such cable gland need to be suitable for the cable used.

ENGLISH

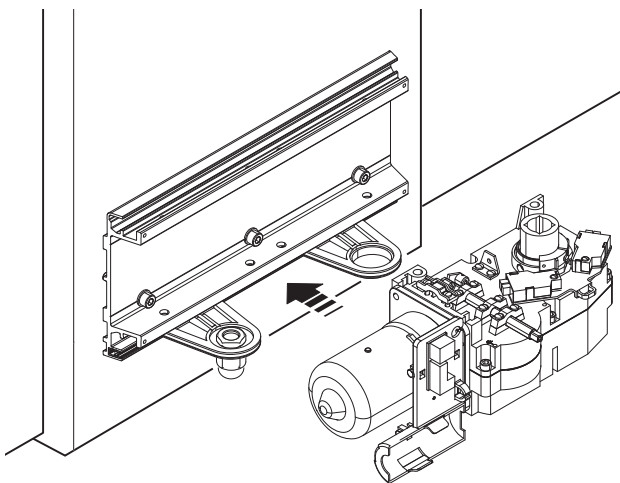
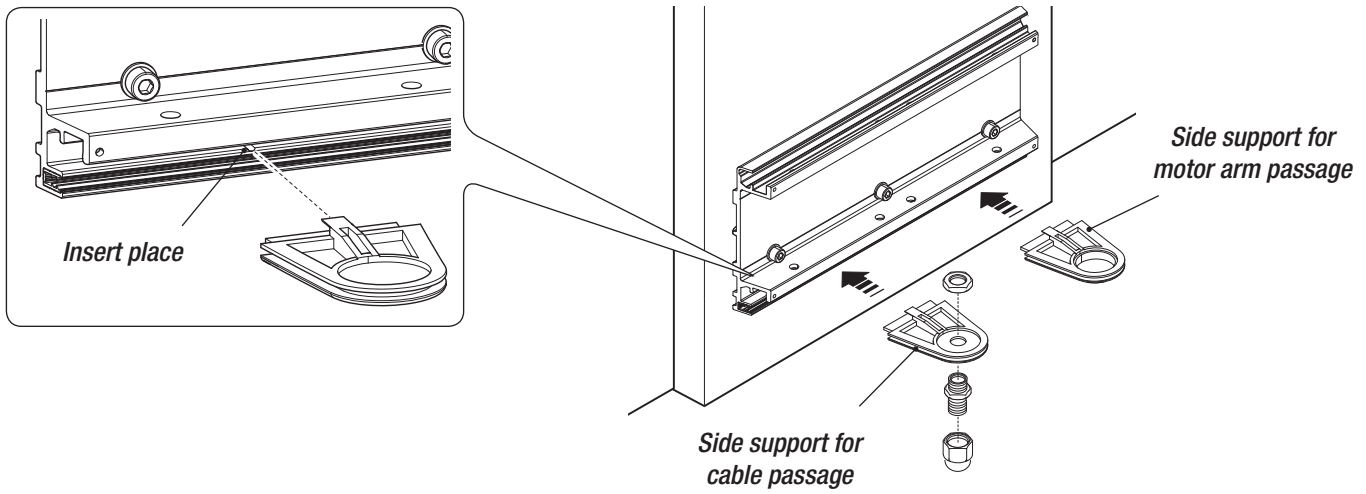

Secure the gearmotor with screws and nuts.

UNI 5931 M8 x 120 screw

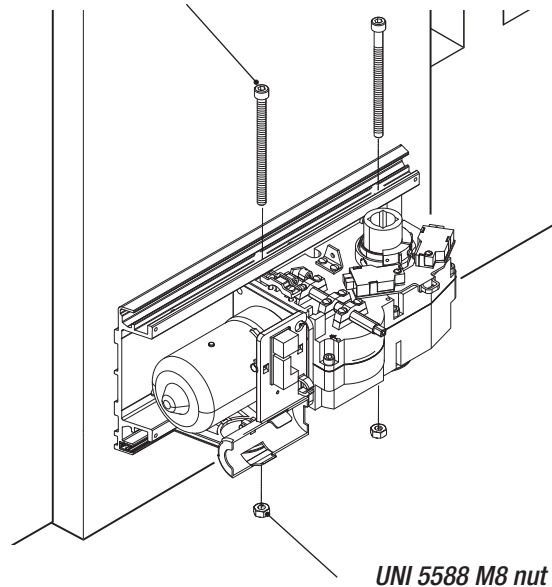

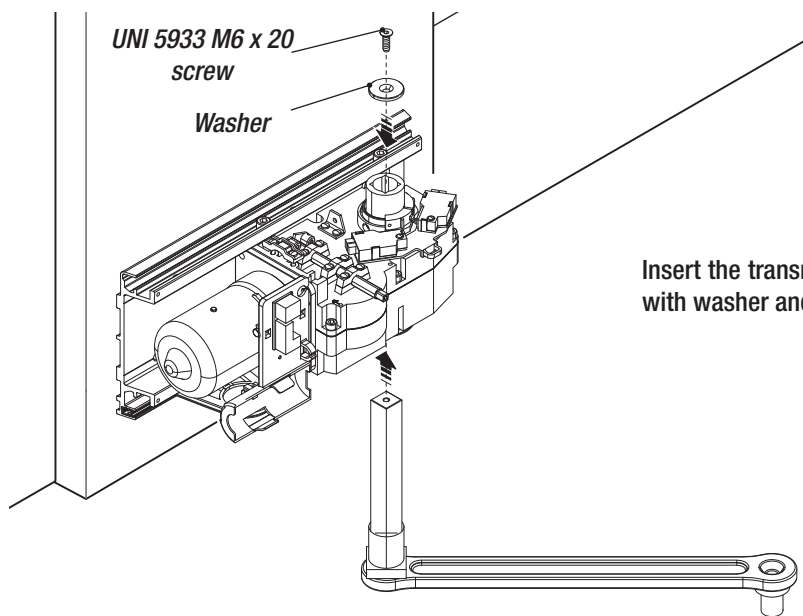

Insert the transmission arm in the motor shaft and secure it with washer and screw.

Assemble the driven arm with transmission arm.

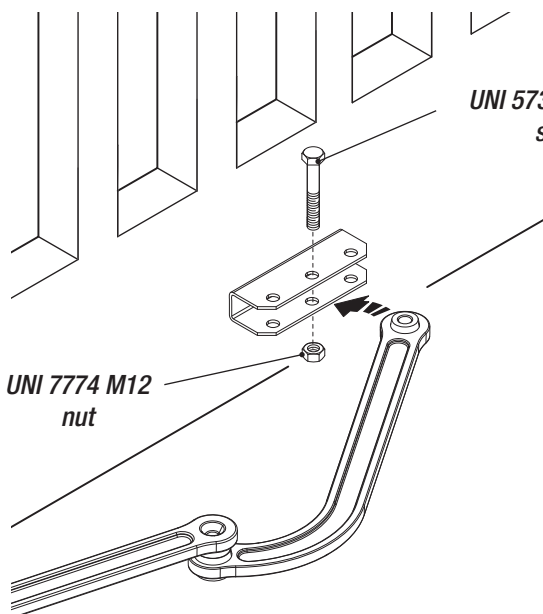
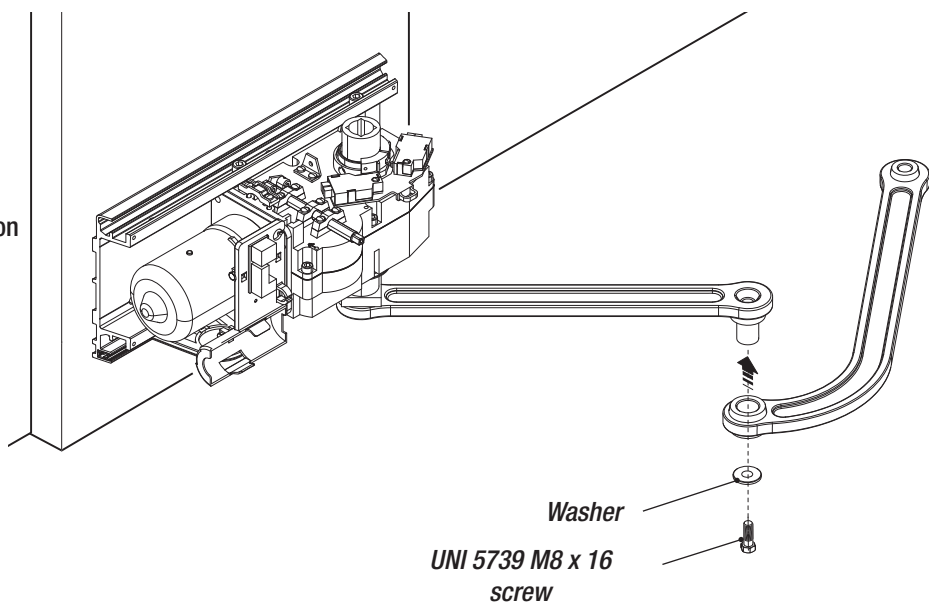

Release the gearmotor and secure the driven arm to the gate-attachment bracket using the nut and bolt.

Warning: in case there are no mechanical stops, securing and adjusting operations for the endstop unit are mandatory.

Securing and adjusting the endstop unit for the LEFT gearmotor

Secure the endstop unit to the gearmotor and fit the cams on the guide.

ENGLISH

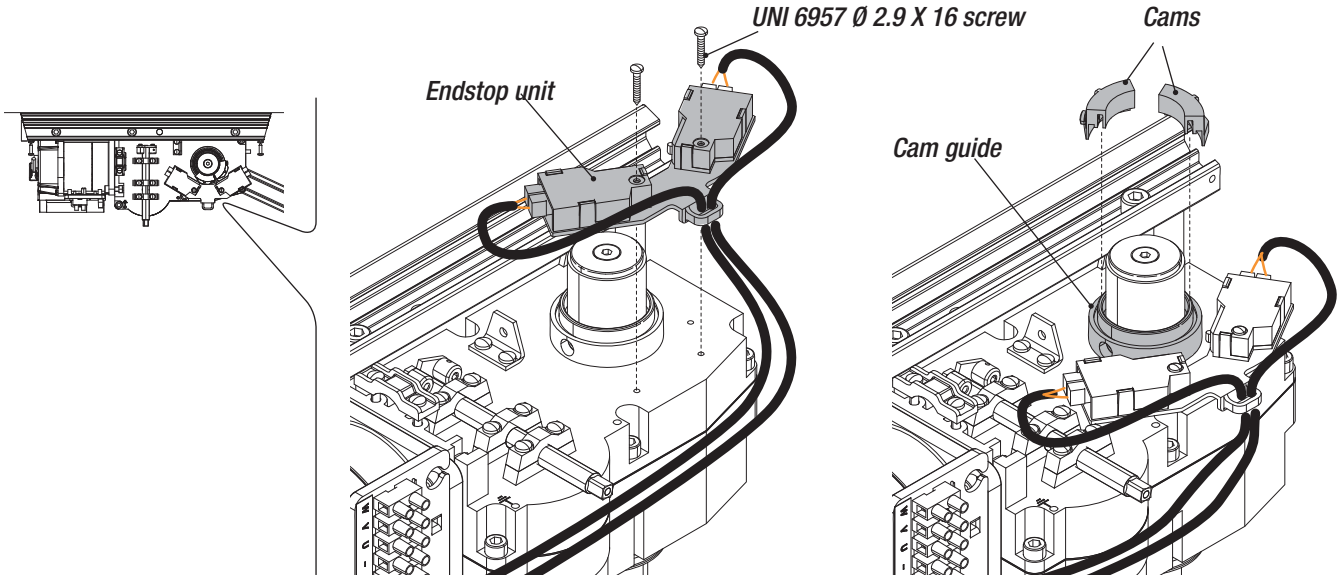

Fully close the gate-leaf of the left gearmotor and rotate the cam counter-clockwise until the closing microswitch inserts. Fix the cam with the screws.

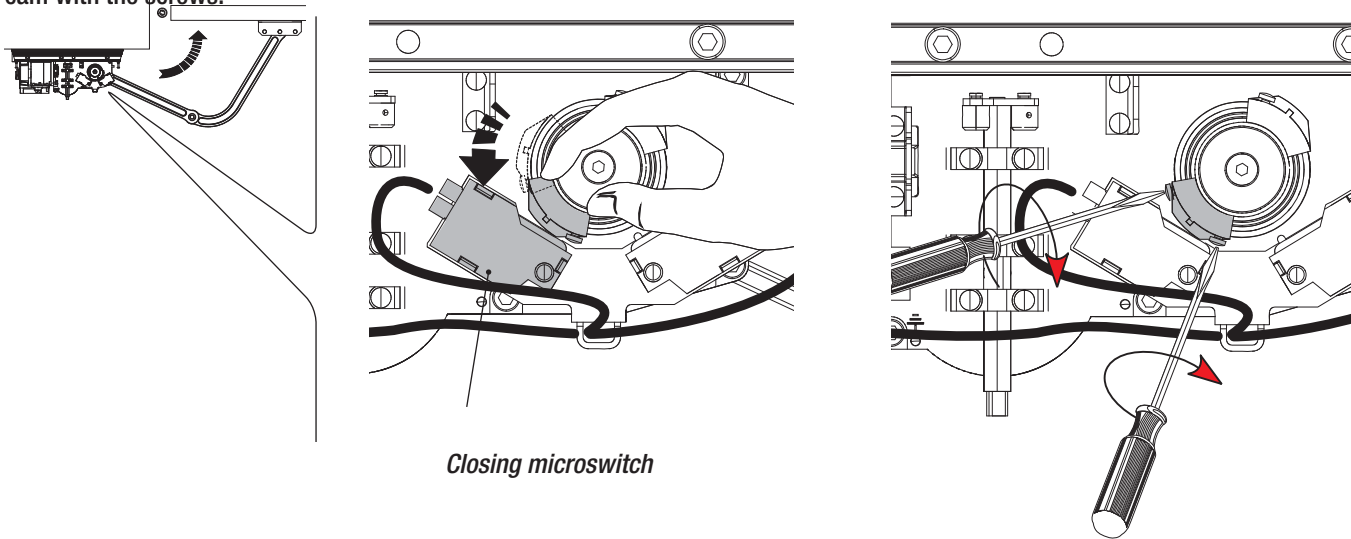

Fully open the gate-leaf of the left gearmotor and rotate the cam counter-clockwise until the closing microswitch inserts. Fix the cam with the screws.

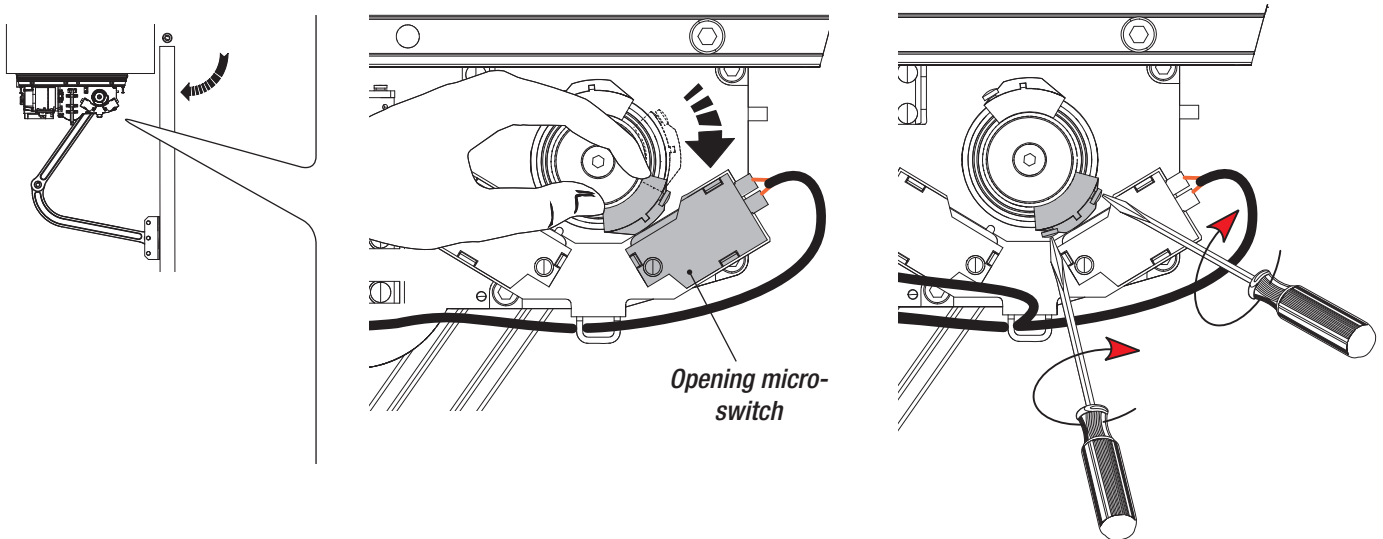

Securing and adjusting the endstop unit for the RIGHT gearmotor

Secure the endpoint assembly to the gearmotor, invert the cables on the microswitches and insert the cams/onto into the guides
UNI 6957 Ø 2.9 X 16 screw

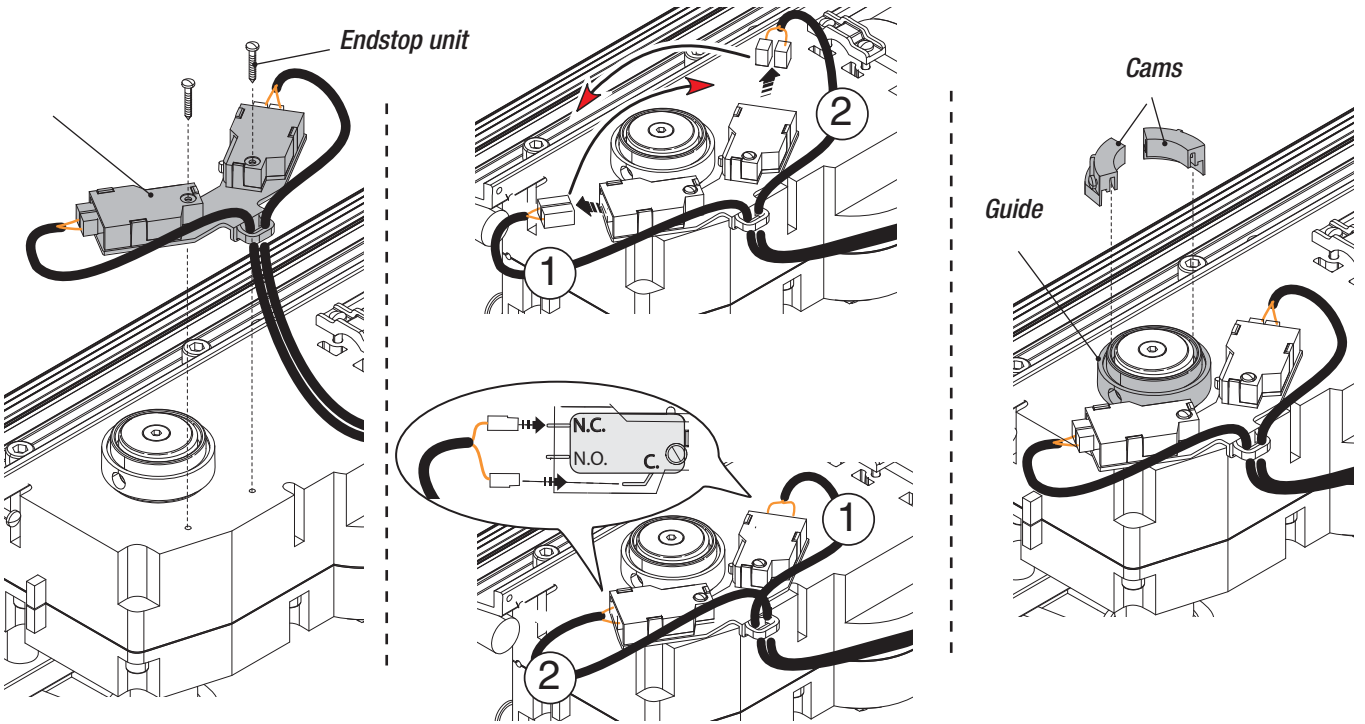

Fully close the gate-leaf of the left gearmotor and rotate the cam clockwise until the closing microswitch inserts. Fix the cam with the screws.

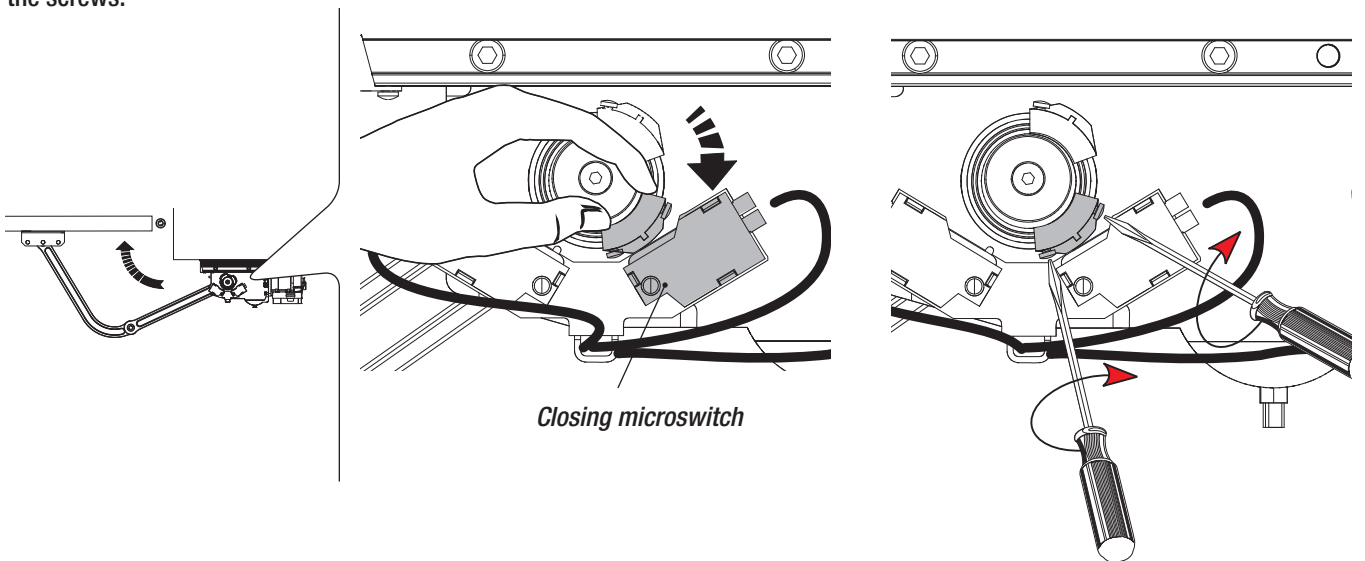

Fully open the gate-leaf and rotate the other cam counter-clockwise until the opening microswitch inserts. Fix the cam with the screws.

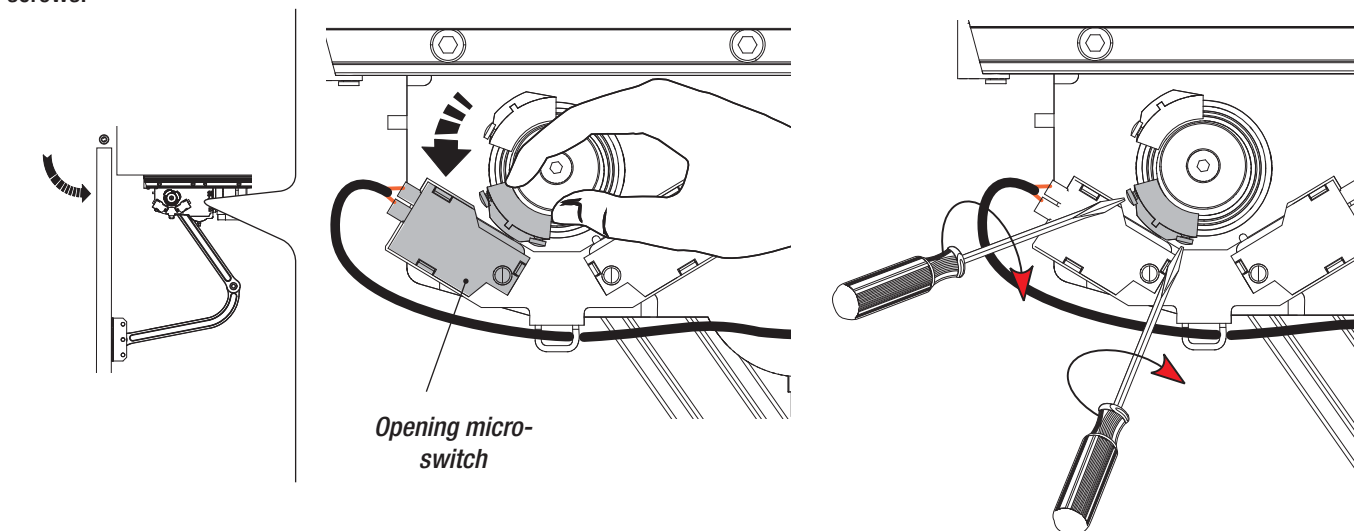

Fixing the side covers and the release handles

Once connections and adjustments are completed, drill through the marked point:

- up for the left gearmotor;
- down for the right gearmotor.

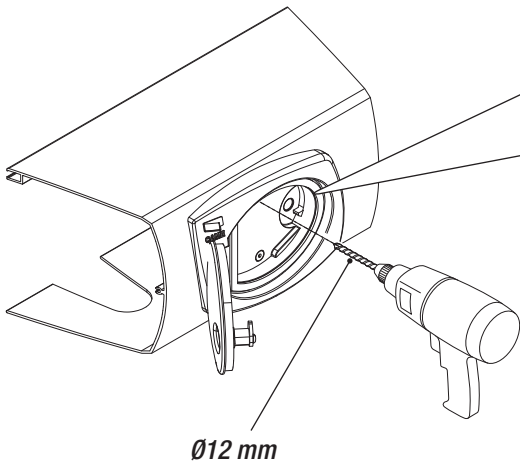

Ø12 mm

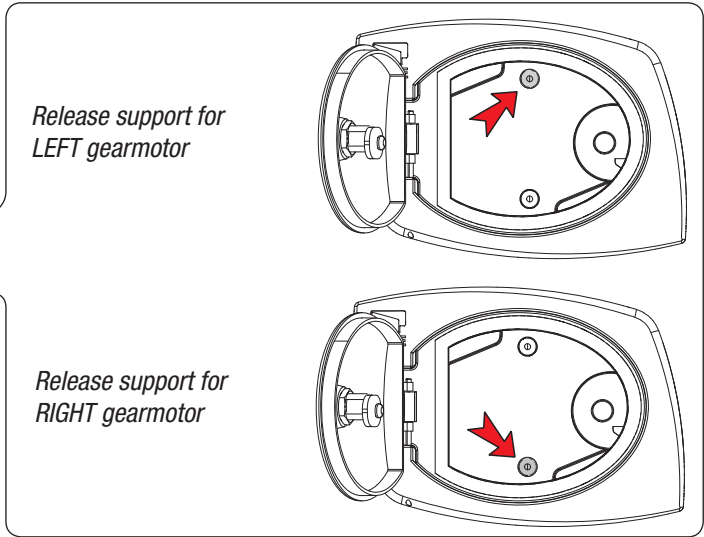

Insert the cover on the bracket.

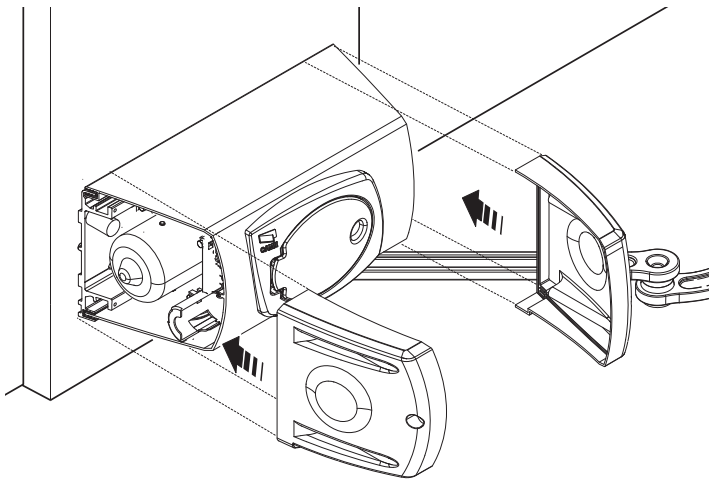
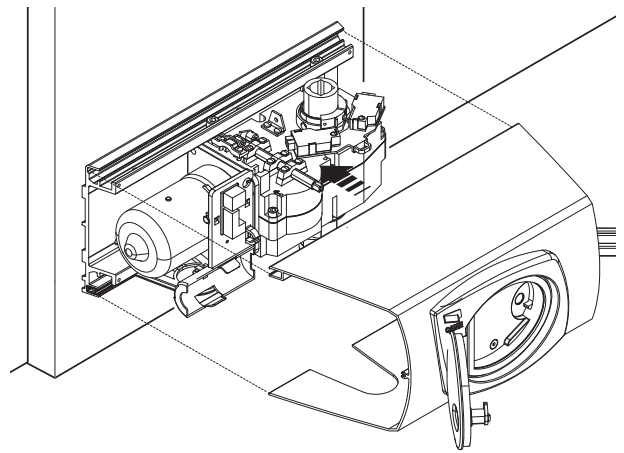

Place the side covers on both sides of the central cover.

Secure the side covers to the pillar bracket using two screws on each side and one screw on the top.

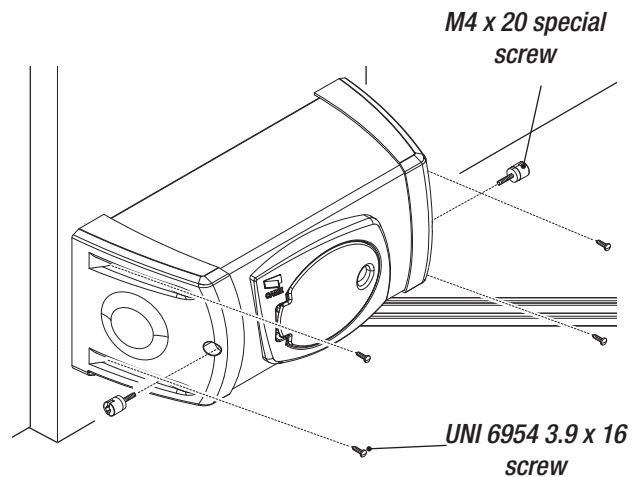

Fit the handle on the release shaft and secure it with screw and washer.

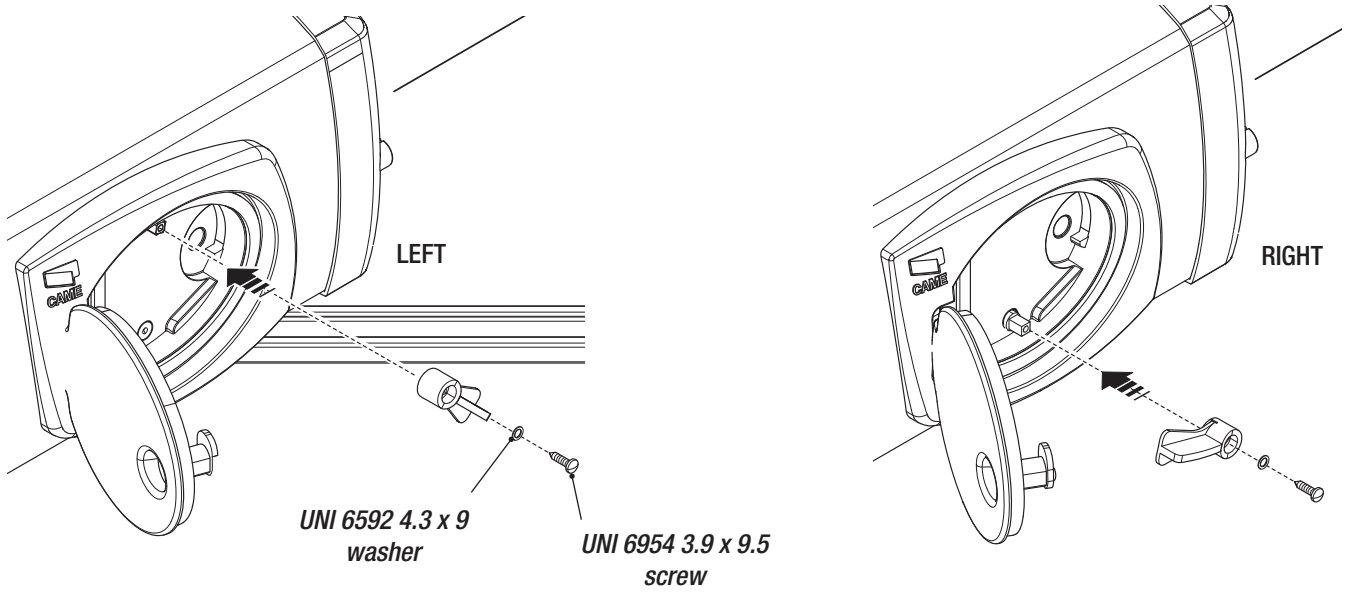

Manual release and locking of the gearmotor

Open the door with the customized key.

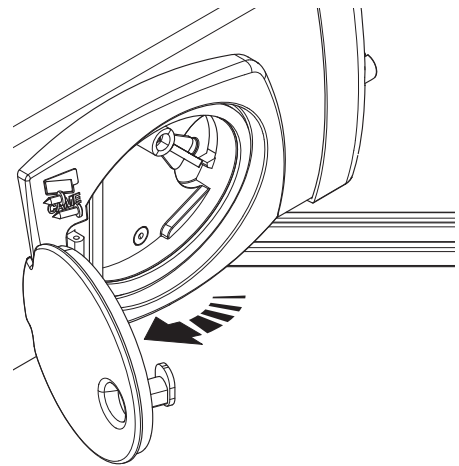
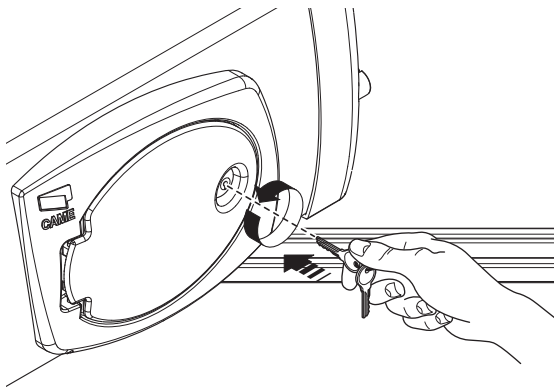

To release the gearmotor, fully clockwise rotate the release lever.
To lock the gearmotor, bring the lever back to original position.

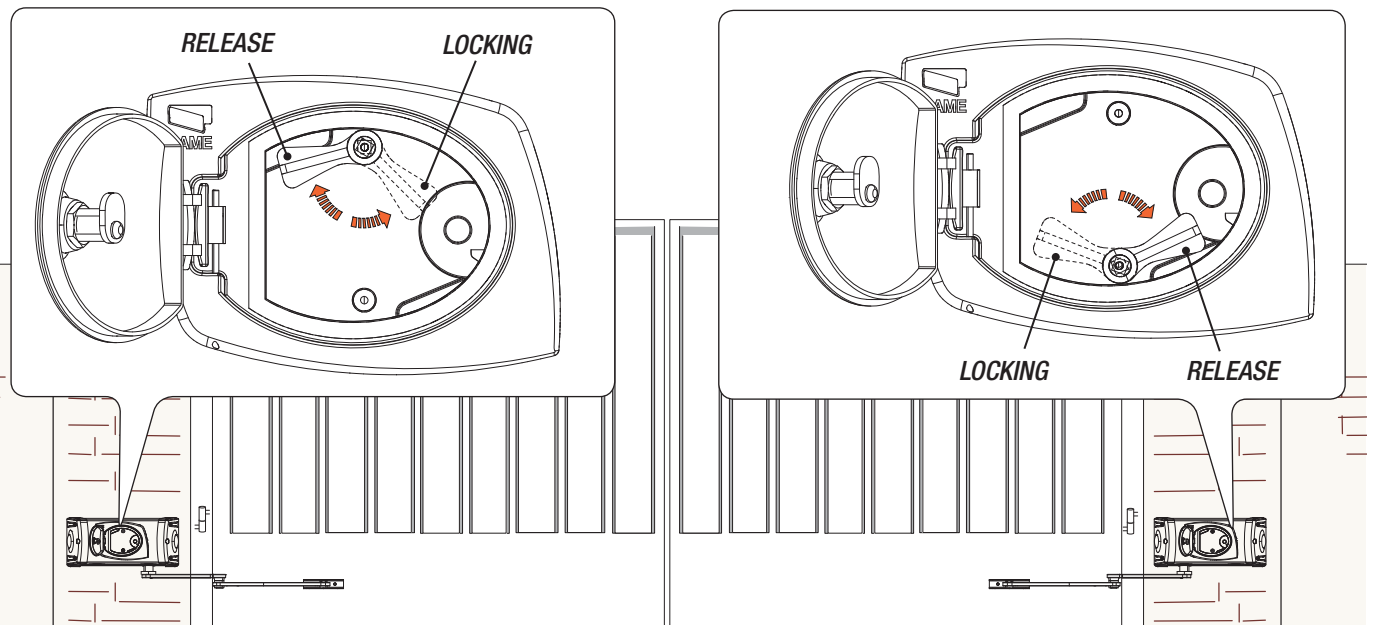

Connecting to the control panel

When making electrical connections, use the pit the junction boxes.
 For further instructions concerning functions and adjustments, consult the control panel's technical manual.

ENGLISH

- 1) Control panel
- 2) Left gearmotor
- 3) Right gearmotor
- 4) Junction box
- 5) Junction pit

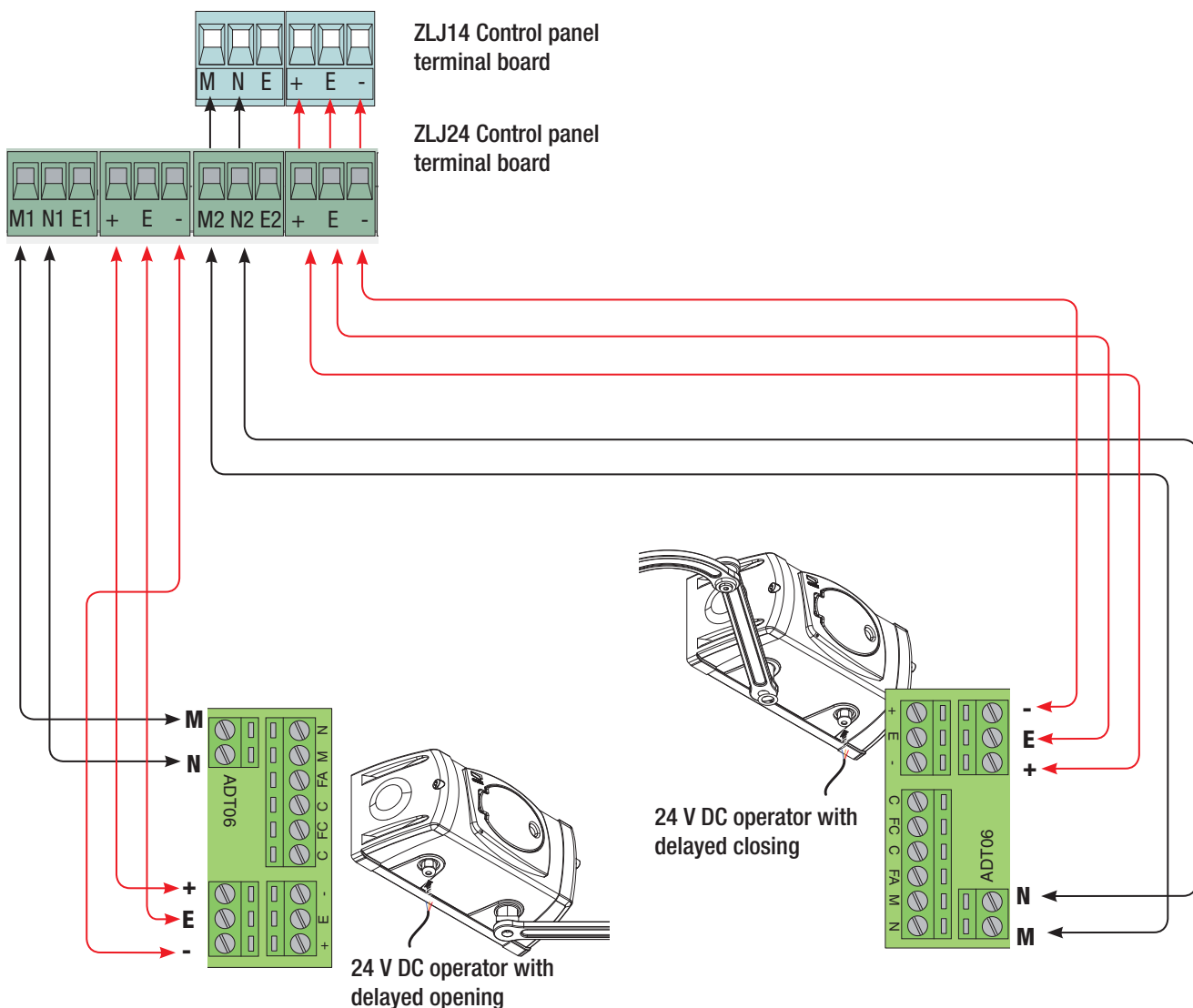
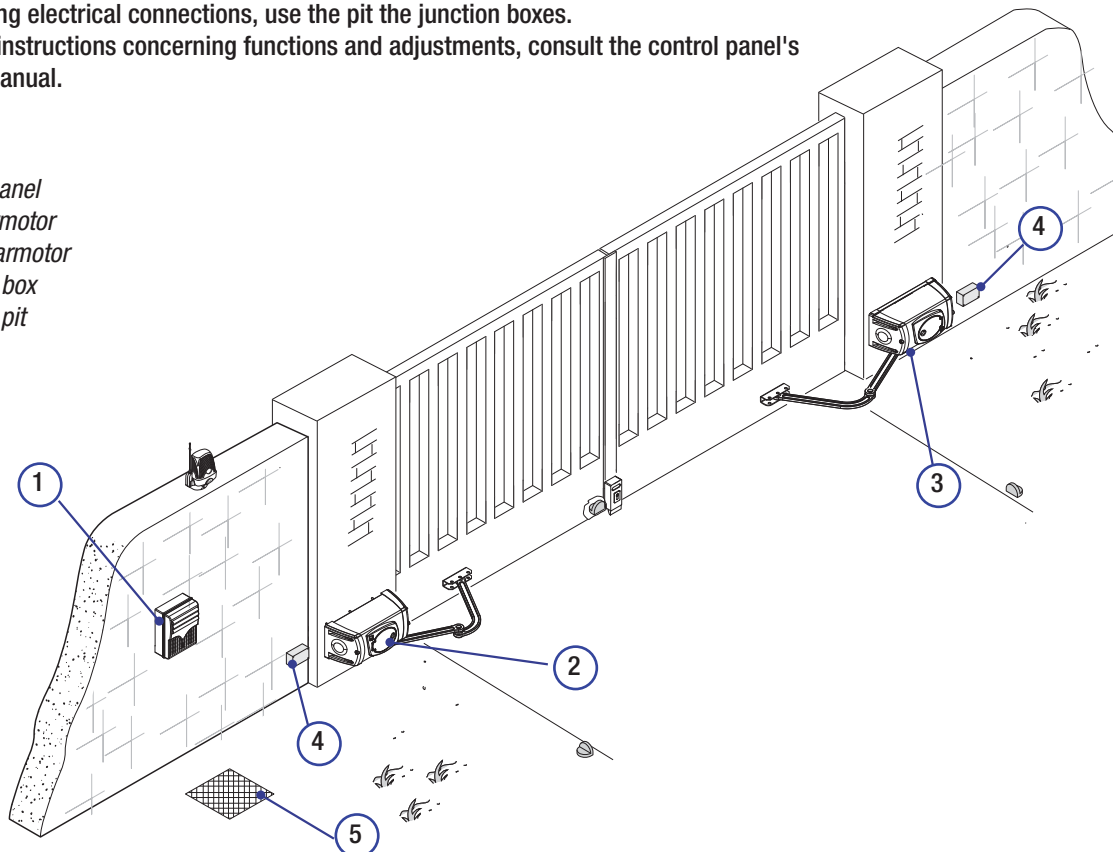

Important safety instructions

This product must only be employed for its originally intended use. Any other use is wrong and potentially dangerous. The manufacturer cannot be held liable for any damages resulting from wrongful, erroneous or negligent uses.

Avoid working close to the hinges or other moving mechanical parts. Stay out of the opening/closing arc when operator is in motion.

Do not exercise force against the motion of the operator as this could result in potentially dangerous situations.

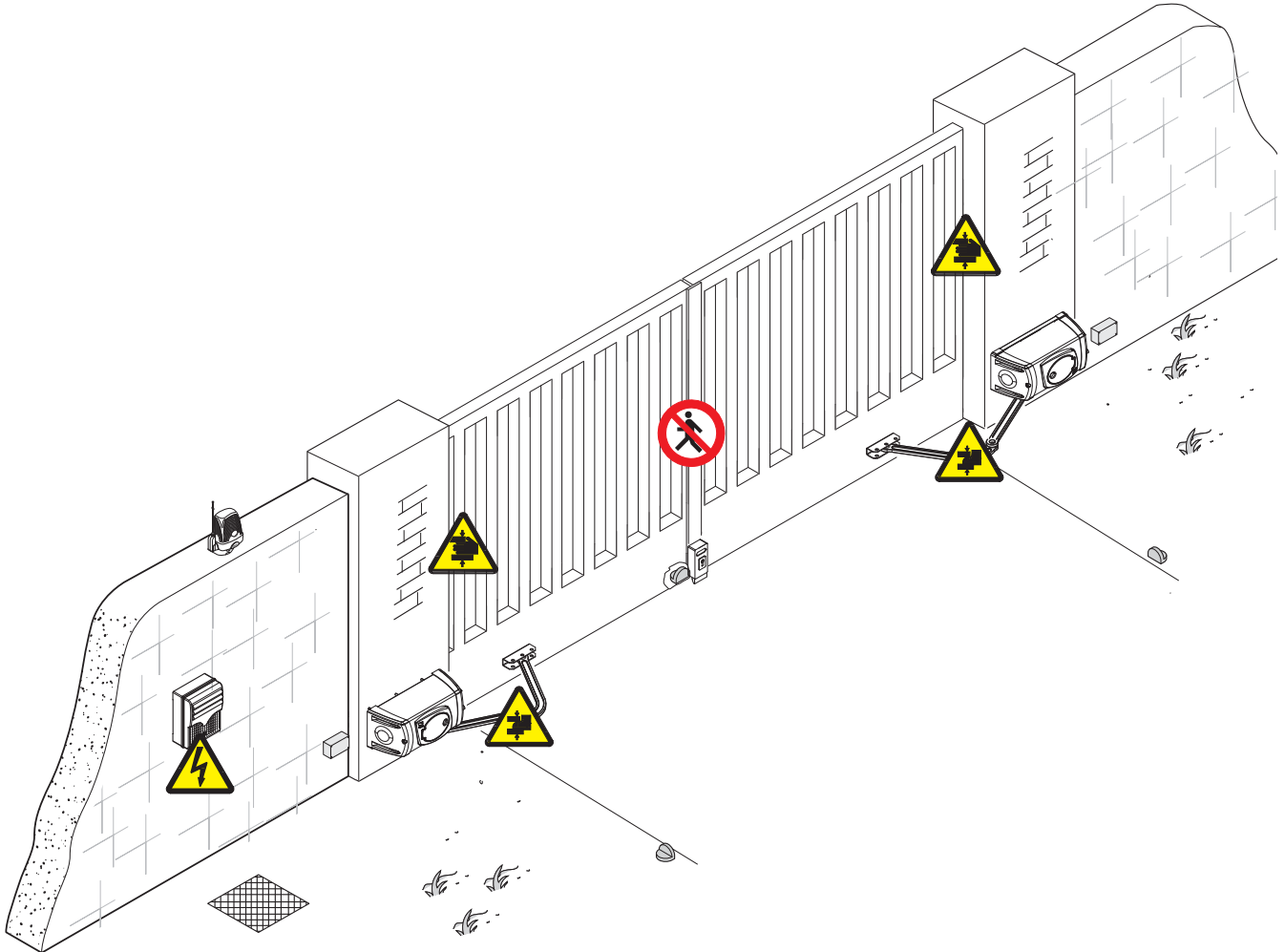

Do not allow children to play or loiter within the opening/closing arc of the operator. Keep transmitters and any other command device out the reach of children, to prevent operator from being activated by accident. In the event of anomalous behaviour, stop using the operator immediately.



Danger of crushing hands



Danger! High voltage



Danger of crushing feet



No transit during operation

Periodic maintenance

 Periodic maintenance to be carried out by the end-user is as follows: wipe clean the glass surface of the photocells; check that the safety devices work properly; remove any obstructions to the proper work of the automation. We suggest checking the state of lubrication and tightness of the anchoring screws on the automation.

To check the efficiency of the safety devices, move an object in front of the photocells when gate is closing. If the operator inverts the motion or stops, the photocells are working properly.

This is the only maintenance procedure to be carried out with the power source connected.

Before performing any maintenance procedures, cut off the main power, to prevent possible accidents due to gate movement.

To clean the photocells use a water dampened cloth. Do not use solvents or other chemical products which may ruin the devices.

In the event of any strange vibrations or squeaking, lubricate the joints with grease, as shown in the diagram.

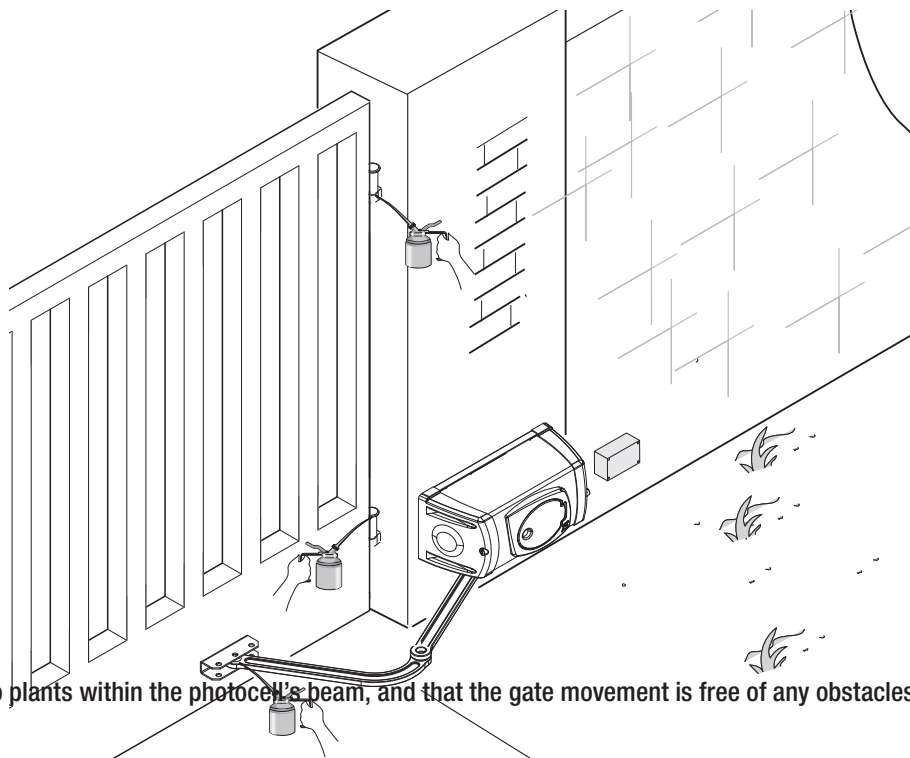

Make sure there are no plants within the photocell's beam, and that the gate movement is free of any obstacles.

Trouble shooting

PROBLEMS	POSSIBLE CAUSES	CHECKS AND REMEDIES
The gate does not open nor close	<ul style="list-style-type: none"> • There is no power supply • The operator is released • The transmitter's battery is flat • The transmitter is broken • The stop button is either stuck or broken • The opening/closing button or the keyswitch selector are stuck 	<ul style="list-style-type: none"> • Check that the power is up • Call assistance • Replace batteries • Call assistance • Call assistance • Call assistance
The gate opens but does not close	<ul style="list-style-type: none"> • The photocells are stressed 	<ul style="list-style-type: none"> • Check that the photocells are clean and in good working order • Call assistance
The flashing light does not work	<ul style="list-style-type: none"> • The bulb is burnt 	<ul style="list-style-type: none"> • Call assistance

Periodic maintenance logTo be done by the end-user (every 6 months)

Date	Notes	Signature

Extra-ordinary maintenance



The following table serves to note down any extraordinary maintenance, repairs or improvements performed by specialised firms.

N.B.: Any extraordinary maintenance must be performed by specialised technicians.

Extra-ordinary maintenance log

Installer's stamp	Operator name
	Date of job
	Technician's signature
	Requester's signature
Job performed _____ _____ _____	

Installer's stamp	Operator name
	Date of job
	Technician's signature
	Requester's signature
Job performed _____ _____ _____	

Installer's stamp	Operator name
	Date of job
	Technician's signature
	Requester's signature
Job performed _____ _____ _____	

Installer's stamp	Operator name
	Date of job
	Technician's signature
	Requester's signature
Job performed _____ _____ _____	

 In its premises, CAME Cancelli Automatici S.p.A. implements an Environmental Management System certified in compliance with the UNI EN ISO 14001 standard to ensure environmental protection.

We ask you to keep protecting the environment, as CAME deems it to be one of the fundamental points of its market operations strategies, by simply following these brief guidelines when disposing:

DISPOSAL OF PACKAGING

The packaging components (cardboard, plastic, etc.) are all classifiable as solid urban waste products and may be disposed of easily, keeping in mind recycling possibilities.

Prior to disposal, it is always advisable to check specific regulations in force in the place of installation.

DO NOT DISPOSE OF IN NATURE!

DISPOSAL OF PRODUCT

Our products are made using different types of materials. Most of them (aluminium, plastics, iron, electrical wires, etc.) may be disposed of in normal garbage collection bins and can be recycled by disposing of in specific recyclable material collection bins and disposal in authorized centres.

Other components (electrical control boards, transmitter batteries, etc.), however, may contain polluting substances.

They should therefore be removed and given to qualified service companies for proper disposal.

Prior to disposal, it is always advisable to check specific regulations in force in the place of disposal.

DO NOT DISPOSE OF IN NATURE!



Came Cancelli Automatici s.p.a.

indirizzo Via Martiri della Libertà n. 15 c.a.p. 31030
loc. Dosson di Casier prov. Treviso stato Italia

DICHIARA CHE LE QUASI MACCHINE

Automazioni per cancelli a battente

A180; A1824; A18230; A3000; A3000A; A3006; A3100; A3106; A3024; A3024N; A5000
A5100; A5000A; A5006; A5106; A5024; A5024N
AX302304; AX402306; AX412306; AX71230; AX3024; AX5024
KR300D; KR300S; KR310D; KR310S; KR510D; KR510S
FROG-A; FROG-AE; FROG-AV; FROG-A24; FROG-A24E; FROG-B; FROG-BI; FROG-J
MYTO-ME
F7000; F7001; F7024; F7024N; F4000; F4024
F1000; F1100; F1024; F500; F510
FE40230; FE4024

RISPETTANO I REQUISITI ESSENZIALI APPLICATI

1.1.3; 1.1.5; 1.2.1; 1.2.2; 1.3.2; 1.3.7; 1.3.8.1; 1.4.1; 1.4.2; 1.5.1; 1.5.6; 1.5.8; 1.5.9;
1.5.13; 1.6.1; 1.6.3; 1.6.4; 1.7.1; 1.7.2; 1.7.4

SONO CONFORMI ALLE DISPOSIZIONI DELLE SEGUENTI DIRETTIVE

DIRETTIVA 2006/42/CE DEL PARLAMENTO EUROPEO E DEL CONSIGLIO
del 17 maggio 2006 relativa alle macchine e che modifica la direttiva 95/16/CE

DIRETTIVA 2004/108/CE DEL PARLAMENTO EUROPEO E DEL CONSIGLIO
del 15 dicembre 2004 concernente il riavvicinamento delle legislazioni degli stati membri relative alla compatibilità
elettromagnetica.

PERSONA AUTORIZZATA A COSTITUIRE LA DOCUMENTAZIONE TECNICA PERTINENTE

Came Cancelli Automatici s.p.a.

indirizzo Via Martiri della Libertà n. 15 c.a.p. 31030
loc. Dosson di Casier prov. Treviso stato Italia

La documentazione tecnica pertinente è stata compilata in conformità all'allegato IIB

Came Cancelli Automatici S.p.A. si impegna a trasmettere, in risposta a una richiesta adeguatamente motivata delle autorità
nazionali, informazioni pertinenti sulle quasi macchine,

VIETA

la messa in servizio finché la macchina finale in cui deve essere incorporata non è stata dichiarata conforme, se del caso alla
2006/42/CE.

Dosson di Casier (TV)
il 16 settembre 2010

Gianni Michielan
Managing Director

DDI B IT A001o ver. 4.1 21 aprile 2010

Dichiarazione in lingua Originale

Came Cancelli Automatici s.p.a.

Via Martiri della Libertà, 15 - 31030 Dosson di Casier - Treviso - Italy - Tel. (+39) 0422 4940 - Fax (+39) 0422 4941
info@came.it - www.came.com

Cap. Soc. 1.610.000,00 € - C.F. e P.I. 03481280265 - VAT IT 03481280265 - REA TV 275359 - Reg Imp. TV 03481280265

CAMEGROUP
freedom innovation

DICHIARAZIONE DI INCORPORAZIONE

(All. IIB Dir.2006/42/CE)



English - Manual code: **T19DV39** ver. 1.1 10/2010 © CAME Cancelli Automatici S.p.A.
The data and information reported in this installation manual are susceptible to change at any time and without obligation on CAME Cancelli Automatici S.p.A. to notify users.

<p>CAME France S.a. 7, Rue Des Haras Z.I. Des Hautes Patures 92737 Nanterre Cedex ☎ (+33) 1 46 13 05 05 ☎ (+33) 1 46 13 05 00</p>	FRANCE	GERMANY	<p>CAME Gmbh Seefeld Akazienstrasse, 9 16356 Seefeld Bei Berlin ☎ (+49) 33 3988390 ☎ (+49) 33 39883985</p>
<p>CAME Automatismes S.a. 3, Rue Odette Jasse 13015 Marseille ☎ (+33) 4 95 06 33 70 ☎ (+33) 4 91 60 69 05</p>	FRANCE	U.A.E.	<p>CAME Gulf Fze Office No: S10122a2o210 P.O. Box 262853 Jebel Ali Free Zone - Dubai ☎ (+971) 4 8860046 ☎ (+971) 4 8860048</p>
<p>CAME Automatismos S.a. C/Juan De Mariana, N. 17-local 28045 Madrid ☎ (+34) 91 52 85 009 ☎ (+34) 91 46 85 442</p>	SPAIN	RUSSIA	<p>CAME Rus Umc Rus Lic Ul. Otradnaya D. 2b, Str. 2, office 219 127273, Moscow ☎ (+7) 495 739 00 69 ☎ (+7) 495 739 00 69 (ext. 226)</p>
<p>CAME United Kingdom Ltd. Unit 3 Orchard Business Park Town Street, Sandiacre Nottingham - Ng10 5bp ☎ (+44) 115 9210430 ☎ (+44) 115 9210431</p>	GREAT BRITAIN	PORTUGAL	<p>CAME Portugal Ucj Portugal Unipessoal Lda Rua Liebig, nº 23 2830-141 Barreiro ☎ (+351) 21 207 39 67 ☎ (+351) 21 207 39 65</p>
<p>CAME Group Benelux S.a. Zoning Ouest 7 7860 Lessines ☎ (+32) 68 333014 ☎ (+32) 68 338019</p>	BELGIUM	INDIA	<p>CAME India Automation Solutions Pvt. Ltd A - 10, Green Park 110016 - New Delhi ☎ (+91) 11 64640255/256 ☎ (+91) 2678 3510</p>
<p>CAME Americas Automation Llc 11345 NW 122nd St. Medley, FL 33178 ☎ (+1) 305 433 3307 ☎ (+1) 305 396 3331</p>	U.S.A	ASIA	<p>CAME Asia Pacific 60 Alexandra Terrace #09-09 Block C, The ComTech 118 502 Singapore ☎ (+65) 6275 8426 ☎ (+65) 6275 5451</p>
<p>CAME Gmbh Kornwestheimer Str. 37 70825 Korntal Munchingen Bei Stuttgart ☎ (+49) 71 5037830 ☎ (+49) 71 50378383</p>	GERMANY		

CAME Cancelli Automatici S.p.a.
Via Martiri Della Libertà, 15
31030 **Dosson Di Casier** (Tv)
☎ (+39) 0422 4940
☎ (+39) 0422 4941
Informazioni Commerciali 800 848095

ITALY

ITALY

CAME Sud s.r.l.
Via F. Imparato, 198
Centro Mercato 2, Lotto A/7
80146 **Napoli**
☎ (+39) 081 7524455
☎ (+39) 081 7529190

CAME Service Italia S.r.l.
Via Della Pace, 28
31030 **Dosson Di Casier** (Tv)
☎ (+39) 0422 383532
☎ (+39) 0422 490044

ITALY

ITALY

CAME Global Utilities s.r.l.
Via E. Fermi, 31
20060 **Gessate** (Mi)
☎ (+39) 02 95380366
☎ (+39) 02 95380224

Assistenza Tecnica 800 295830

