

Brio®



Brio® where ideas unfold

**Brio® Residential**  
Pack Set Range

## **Brio® where ideas unfold**

Watch your adventurous architectural ideas unfold into exciting reality with the Brio range of sliding and folding door hardware.

Brio is passionate about shaping the spaces in which people live, work and play. With subsidiaries in the UK and USA – Brio is recognised by architects worldwide as a leading design and manufacturing company.

Brio's R&D department brings a strong design element to the business, developing and testing ground breaking concepts that continue to be at the forefront of the industry.

So it's no surprise our name Brio translates to Energy, Spirit and Vitality – the core values that drive us to always discover new solutions for our customers.

We are committed to the continuous improvement of quality. That is why Brio, located in Sydney, is certified to Quality Management System AS/NZS ISO 9001:2008.

Brio, part of the Allegion family of brands



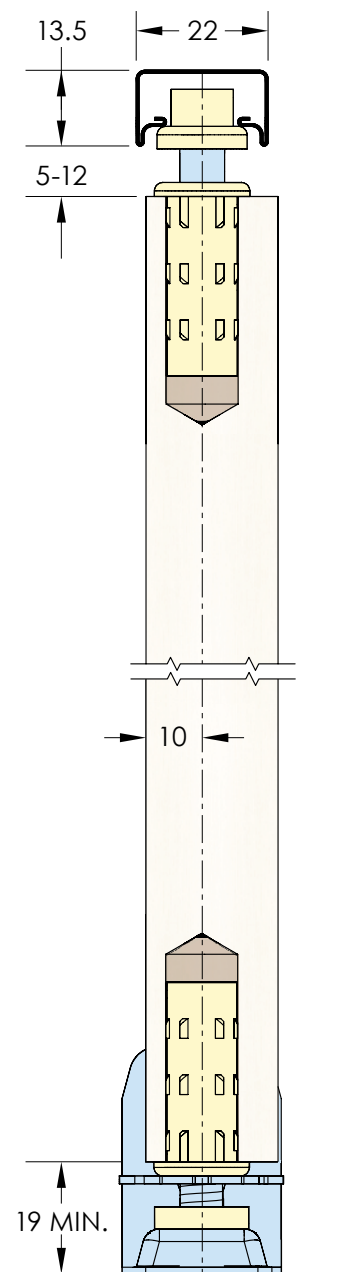

# Bifold 16

Max Panel Weight	Max Panel Width	Max Panel Height	Min Panel Thickness	Height Adjustment	Horizontal Adjustment
<b>16kg</b>	<b>620mm</b>	<b>2400mm</b>	<b>23mm</b>	<b>± 3.5mm</b>	<b>± 4mm</b>

## Application

Bifold 16 is a simple to install, folding door hardware system for panels weighing less than 16kg. Neither top hung or bottom rolling; Bifold 16 supports the panels at the pivot base and incorporates spring loaded guides at the head. Bifold 16 is designed to be used without a bottom channel which makes it ideal for cupboards, pantries, laundry rooms and room dividers. The top channel is only 13.5mm high which maximises the opening and is easy to conceal.

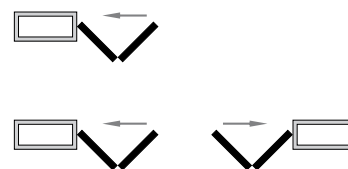

## Sets Available

### BF16-09/2

Opening Width: Up to 915mm, 2 Panels

### BF16-12/2

Opening Width: Up to 1250mm, 2 Panels

### BF16-18/4

Opening Width: Up to 1830mm, 4 Panels

### BF16-25/4

Opening Width: Up to 2500mm, 4 Panels

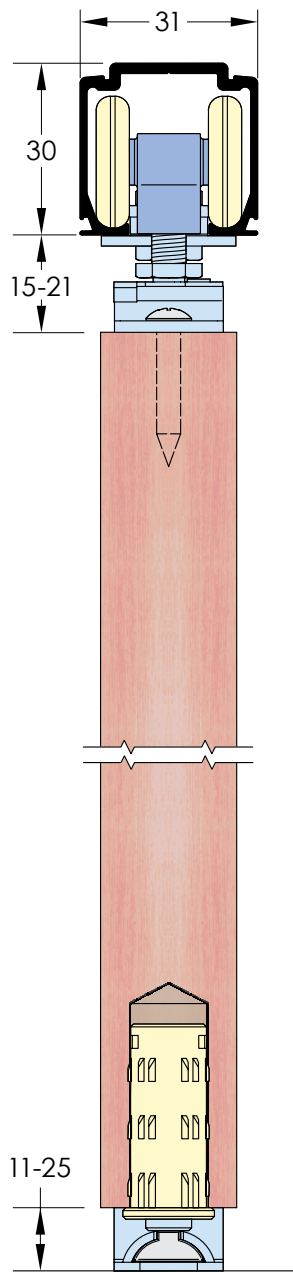

# Multifold 30

Max Panel Weight <b>30kg</b>	Max Panel Width <b>650mm</b>	Max Panel Height <b>2400mm</b>	Min Panel Thickness <b>19mm</b>	Height Adjustment <b>± 3mm</b>	Horizontal Adjustment <b>± 4mm</b>
---------------------------------	---------------------------------	-----------------------------------	------------------------------------	-----------------------------------	---------------------------------------

## Application

Multifold 30 from Brio is a versatile, interior folding door hardware system. The axis on the pivot and hangers sits within 25mm of the edge of the door, minimising the overhang of the panels, improving appearance and making it possible to fit trim to hide the gap between track and panel. The hanger includes four precision bearings and a quick release plate. This with the single spanner height adjustment makes installation easy.

## Sets Available

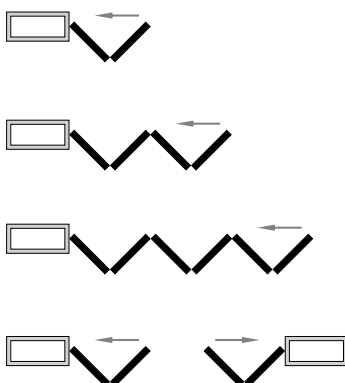

- MF30-13/2**  
Opening Width: Up to 1300mm for 2 Panels
- MF30-26/4**  
Opening Width: Up to 2600mm for 4 Panels  
Folding to one side

- MF30-2PK**  
2 Panel Pack
- MF30-4PK**  
4 Panel Pack
- MF30-APK**  
2 Panel Add on Pack
- MF30-6PK**  
6 Panel Pack



# Sprintline 30

Max Panel Weight	Max Panel Width	Max Panel Height	Min Panel Thickness	Height Adjustment	Horizontal Adjustment
<b>30kg</b>	<b>1500mm</b>	<b>2400mm</b>	<b>25mm</b>	<b>± 8mm</b>	<b>-</b>

## Application

Sprintline 30, the ever popular slide is now even better. The track is made from extruded aluminium for a smooth, quiet motion. The height can accurately be adjusted whilst the hanger takes the full weight of the panel. The pelmet is also made from extruded aluminium and is available in powder coat white.

## Sets Available

**SL30-16/1**  
Track Length: 1600mm, Single Panel

**SL30-24/1**  
Track Length: 2400mm, Single Panel

**Pelmet with End Caps 170-18**  
Pelmet Length: 1800mm

**Pelmet with End Caps 170-30**  
Pelmet Length: 3050mm

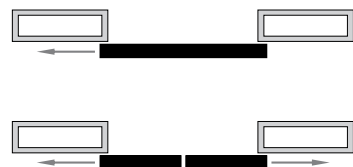

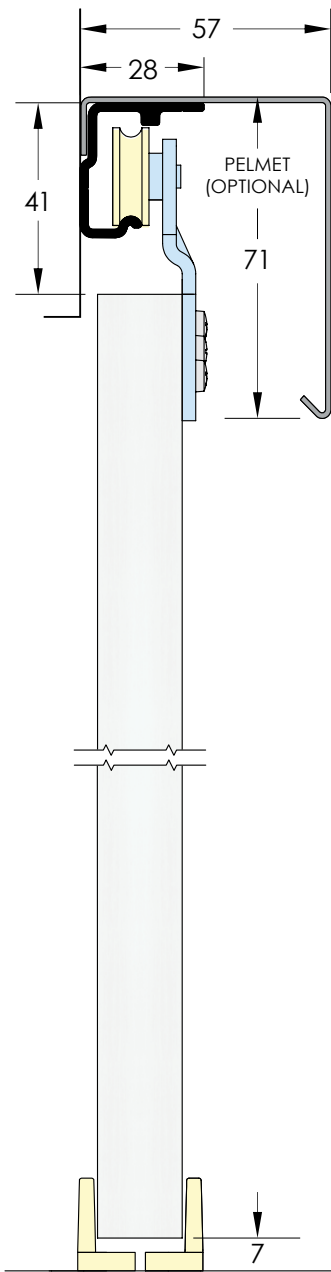

## Wardrobe Single 50

Max Panel Weight	Max Panel Width	Max Panel Height	Min Panel Thickness	Height Adjustment	Horizontal Adjustment
<b>50kg</b>	<b>900mm</b>	<b>2400mm</b>	<b>16mm</b>	<b>± 5mm</b>	<b>-</b>

### Application

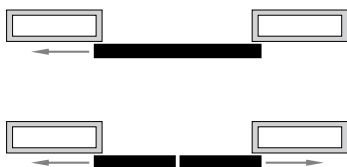

Wardrobe Single 50 is a durable heavy duty slide with an adjustable face fix hanger suitable for thin medium density fibre (MDF) board. The high speed, precision sealed bearings ensure extended life and smooth operation as the hangers run on an aluminium rail. The track can be soffit or face fixed and dressed with an optional powder coat white, aluminium pelmet.

### Sets Available

- WS50-12/1**  
Track Length: 1200mm, Single Panel
- WS50-15/1**  
Track Length: 1500mm, Single Panel
- WS50-18/1**  
Track Length: 1800mm, Single Panel

**Pelmet with End Caps 170-18**  
Pelmet Length: 1800mm

**Pelmet with End Caps 170-30**  
Pelmet Length: 3050mm

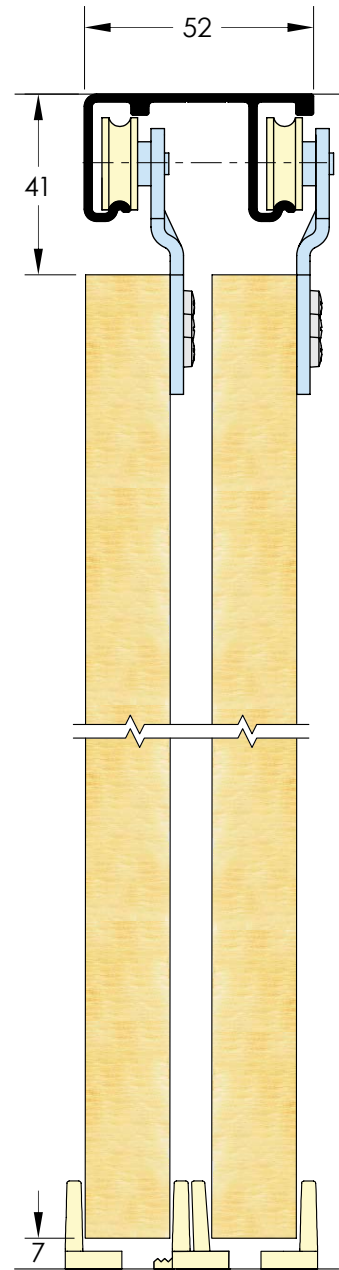

# Wardrobe Double 50

Max Panel Weight	Max Panel Width	Max Panel Height	Min Panel Thickness	Height Adjustment	Horizontal Adjustment
<b>50kg</b>	<b>900mm</b>	<b>2400mm</b>	<b>16mm</b>	<b>± 5mm</b>	<b>-</b>

## Application

Wardrobe Double 50, as the name implies, is designed specifically for wardrobes. It is a top hung system that can accommodate panels weighing 50kg each. The face fix hangers are adjustable and fitted on the blind side of the opening. Wardrobe Double 50 can be extended to three panels on three lines by adding Wardrobe Single 50 to run in parallel.

The expectation of wardrobes is they operate in silence. Brio is one of a few manufacturers that use precision bearings as standard to reduce noise and ensures the system remains that way.

## Sets Available

### WD50-12/2

Opening Width: 1200mm, 2 Panels

### WD50-15/2

Opening Width: 1500mm, 2 Panels

### WD50-18/2

Opening Width: 1800mm, 2 Panels

### WD50-24/3

Opening Width: 2400mm, 3 Panels

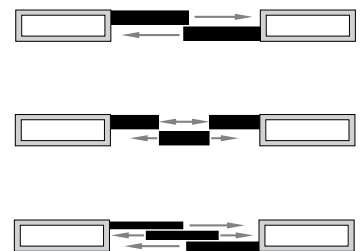

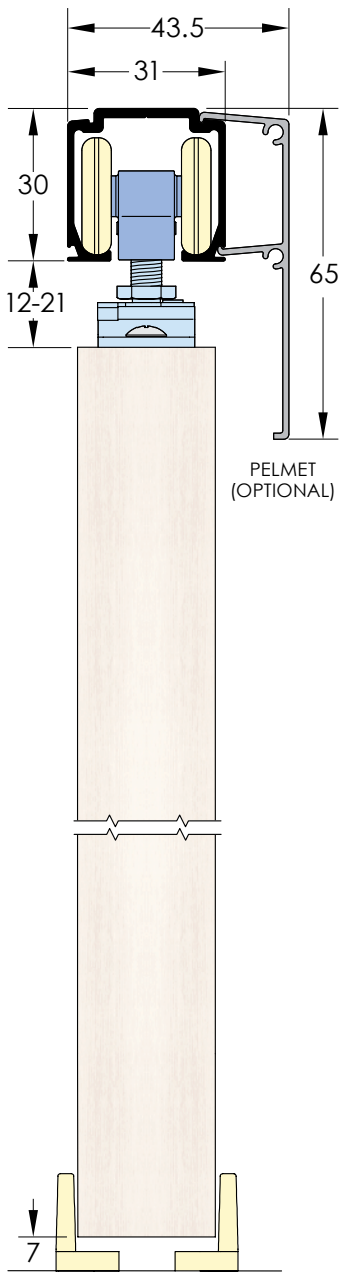

## Single Run 60

Max Panel Weight	Max Panel Width	Max Panel Height	Min Panel Thickness	Height Adjustment	Horizontal Adjustment
<b>60kg</b>	<b>1525mm</b>	<b>2400mm</b>	<b>19mm</b>	<b>± 4.5mm</b>	<b>-</b>

### Application

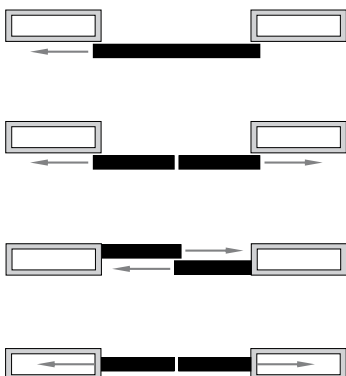

Single Run 60 is the most versatile of all slides, with a full 'C' section aluminium track and 4 wheels per hanger, it offers long life, stability and a high capacity of 60kg. Two, quick release plate options allow for either standard straight sliding applications with side feed access or a cavity door application with end feed access. Both offer easy height adjustment with a single spanner (supplied). The Single Run sets are supplied with clip stops or 2 soft close devices. The Cavity Run kits do not include clip stops or soft close.

### Kits Available

**SR60-20/1 or SR60-S20/1**  
Track Length: 2000mm,  
Single Panel

**CR60-20/1**  
Track Length: 2000mm,  
Single Panel

**SR60-1PK**  
Pack of Fittings only

**SR60-30/1 or SR60-S30/1**  
Track Length: 3000mm,  
Single Panel

**CR60-30/1**  
Track Length: 3000mm,  
Single Panel

**CR60-1PK**  
Pack of Fittings only

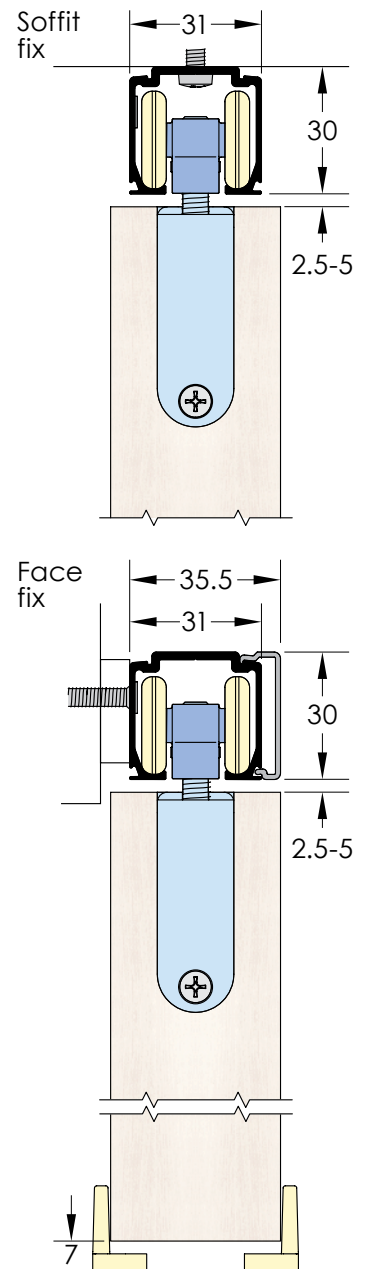

# Zero Clearance 60

Max Panel Weight	Max Panel Width	Max Panel Height	Min Panel Thickness	Height Adjustment	Horizontal Adjustment
<b>60kg</b>	<b>1525mm</b>	<b>2400mm</b>	<b>28mm</b>	<b>± 4mm</b>	<b>-</b>

## Application

Zero Clearance 60 discreetly conceals the hanger plate inside the top of the door which provides a sleek look for any application. Zero Clearance sets are for standard straight sliding panels while Cavity Clearance is specially designed for pocket doors, all sets are available with clip stops or soft close devices. Zero Clearance sets also offer a face fix option where the track is punched and supplied with aluminium pelmet.

## Sets Available

### ZC60-20/1 or ZC60-S20/1

Track Length: 2000mm, Single Panel

### ZC60-30/1 or ZC60-S30/1

Track Length: 3000mm, Single Panel

### ZC60F-S20/1CA or ZC60F-S20/1PWT

Track Length: 2000mm, Single Panel

### CC60-20/1 or CC60-S20/1

Track Length: 2000mm, Single Panel

### CC60-30/1 or CC60-S30/1

Track Length: 3000mm, Single Panel

### ZC60-1PK

Pack of Fittings only

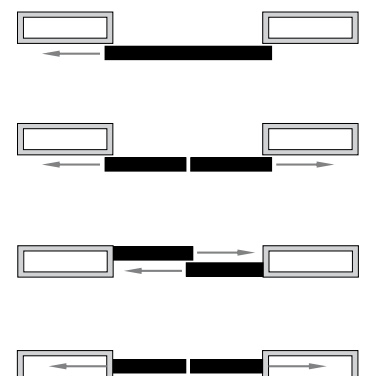

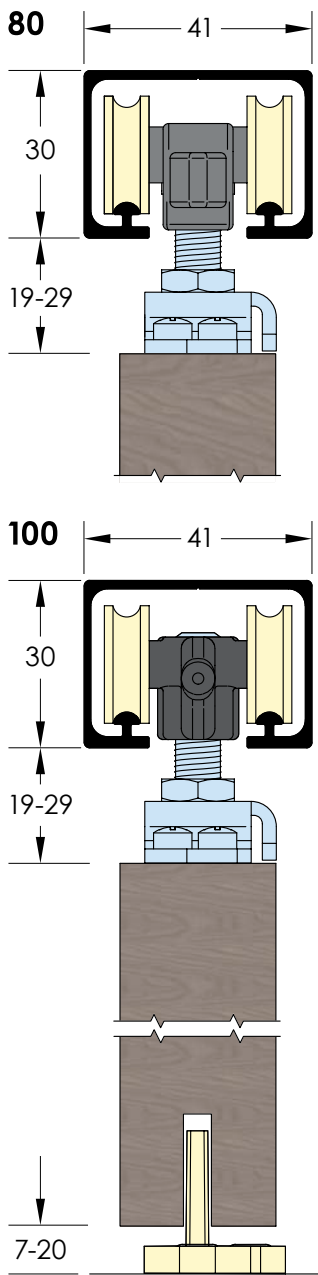

## Single Run 80 and 100

Max Panel Weight	Max Panel Width	Max Panel Height	Min Panel Thickness	Height Adjustment	Horizontal Adjustment
<b>80/100kg</b>	<b>2000mm</b>	<b>3000mm</b>	<b>28mm</b>	<b>± 5mm</b>	<b>-</b>

### Application

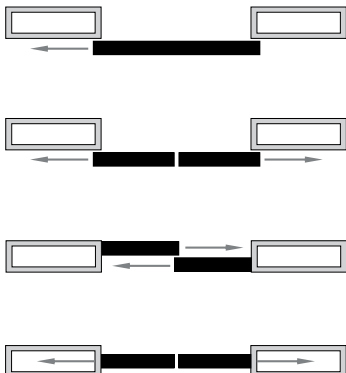

Single Run 80 and Single Run 100 are available as sets or loose parts. These systems bridge residential to light commercial applications for panels of 80kg or 100kg which are likely to be custom made for their application. Single Run 80 uses a structural polymer hanger while Single Run 100 has a cast alloy body. Both systems run inside an aluminium track which is square cut for a contemporary, clean look. Sets are supplied with clip stops as standard but these can be upgraded to soft close devices which operate by catching the moving panel and absorbing its speed before gently pulling it in to the jamb ensuring a quiet stop and protecting small hands from slamming doors.

### Sets Available

**SR80-20/1**  
Track Length: 2000mm,  
Single Panel

**SR80-30/1**  
Track Length: 3000mm,  
Single Panel

**SR100-20/1**  
Track Length: 2000mm,  
Single Panel

**SR100-30/1**  
Track Length: 3000mm,  
Single Panel

**SR80-1PK**  
80kg Pack of Fittings only

**SR100-1PK**  
100kg Pack of Fittings only

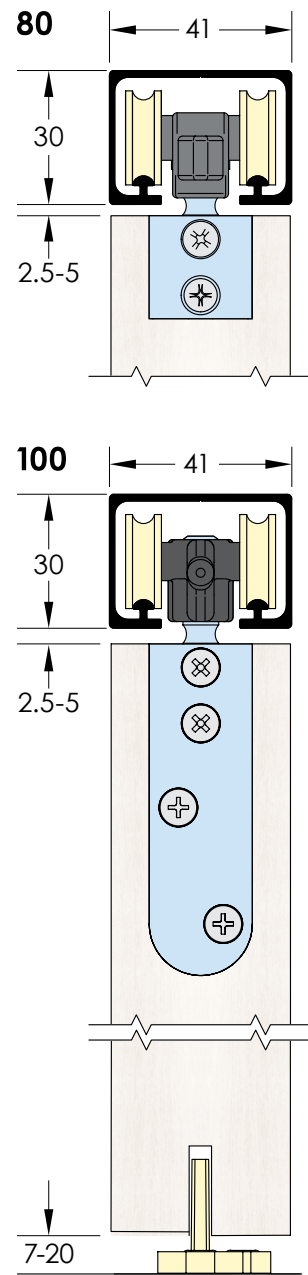

## Zero Clearance 80 and 100

Max Panel Weight	Max Panel Width	Max Panel Height	Min Panel Thickness	Height Adjustment	Horizontal Adjustment
<b>80/100kg</b>	<b>2000mm</b>	<b>3000mm</b>	<b>32mm</b>	<b>± 2.0mm</b>	<b>-</b>

### Application

Zero Clearance 80 and 100 are the definitive straight sliding systems as panels appear to float just below the track meaning there are no large gaps or hardware to hide. Zero Clearance uses an ingenious sliding rail mechanism rebated into the top of the panel to achieve these ultra low clearances. To adjust the height, simply loosen the end cap and slide the inner sleeve out to gain access to the hanger bolt. When assembled, no further adjustment is possible meaning the panel's height can not slip over time. Brio's soft close accessory is also available, clip stops supplied in sets.

### Sets Available

#### ZC80-20/1

Track Length: 2000mm,  
Single Panel

#### ZC80-30/1

Track Length: 3000mm,  
Single Panel

#### ZC100-20/1

Track Length: 2000mm,  
Single Panel

#### ZC100-30/1

Track Length: 3000mm,  
Single Panel

#### ZC80-1PK

80kg Pack of Fittings only

#### ZC100-1PK

100kg Pack of Fittings only

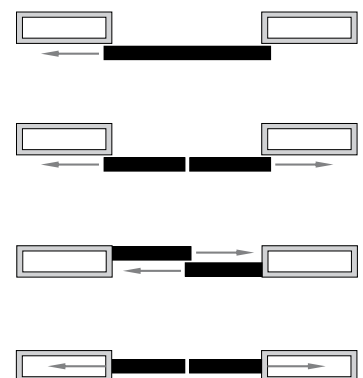

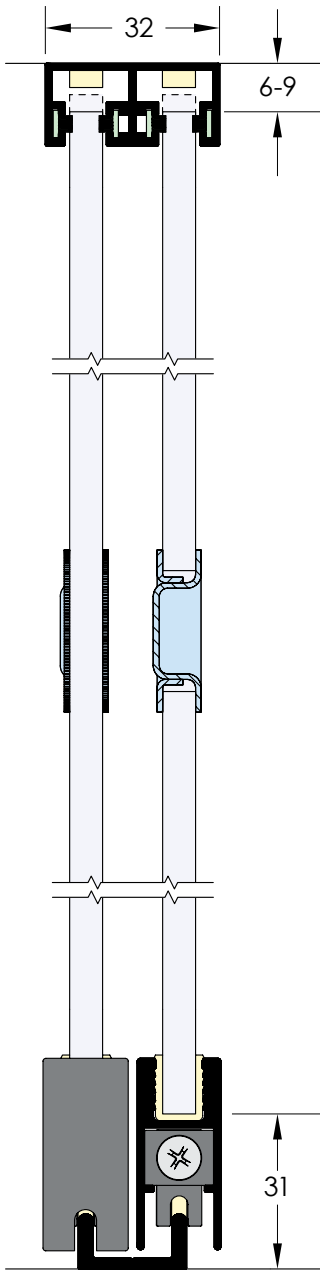

## Glassroll 30

Max Panel Weight	Max Panel Area	Max Panel Height	Min Panel Thickness	Height Adjustment	Horizontal Adjustment
<b>30kg</b>	<b>2.5m<sup>2</sup></b>	—	<b>6mm</b>	<b>± 1.5mm</b>	—

### Application



Glassroll 30 is ideal for cabinets and display units. Glassroll 30 is one of the easiest cabinet systems to install and adjust. Unlike many others there is no need to remove and replace the panel numerous times to find the optimum height. Adjustment is possible with the glass panel in place, making installation accurate, quick and easy. For security, Glassroll comes with its own dedicated lock as an optional extra, which fits to the glazing rail.

### Sets Available

#### GR30-12/2

Opening Width: 1200mm, 2 Panels

#### GR30-15/2

Opening Width: 1500mm, 2 Panels

#### GR30-18/2

Opening Width: 1800mm, 2 Panels

# Accessories

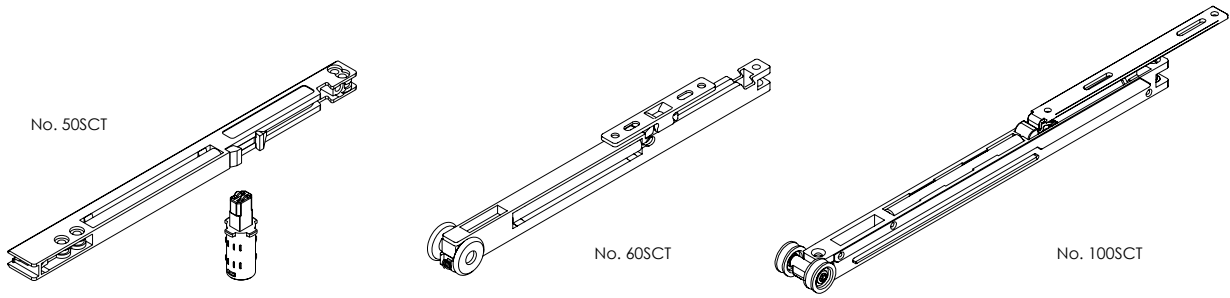

No. 50SCT

No. 60SCT

No. 100SCT

**Soft Close**  
Wardrobe Roll 50

**Soft Close**  
Single Run 60  
Zero Clearance 60

**Soft Close**  
Single Run 80/100  
Zero Clearance 80/100

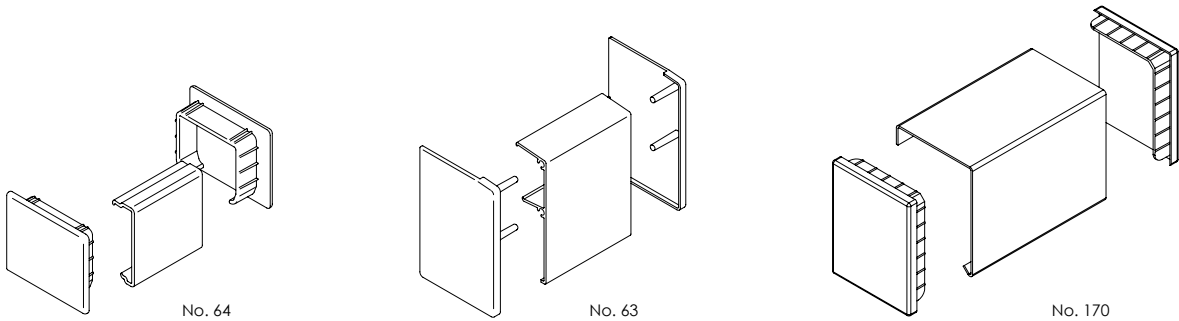

No. 64

No. 63

No. 170

**Pelmet and End Caps**  
Zero Clearance 60

**Pelmet and End Caps**  
Single Run 60

**Pelmet and End Caps**  
Sprintline 30  
Wardrobe Single 50

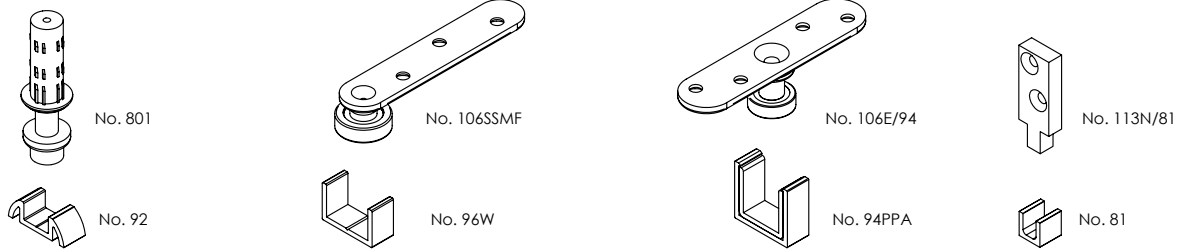

No. 801

No. 92

No. 106SSMF

No. 96W

No. 106E/94

No. 94PPA

No. 113N/81

No. 81

**Alternative spring loaded guide & channel**  
Multifold 30  
Single Run 60

**Alternative guide & channel**  
Multifold 30  
Single Run 80/100  
Zero Clearance 80/100

**Alternative guide & channel with poly.**  
Single Run 80/100  
Zero Clearance 80/100

**Alternative guide & channel**  
Wardrobe

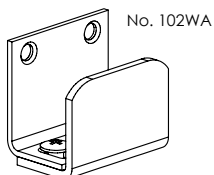

No. 102WA

**Alternative saw cut guide**  
Sprintline 30  
Single Run 60

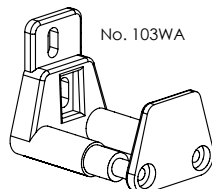

No. 103WA

**Alternative guide**  
Sprintline 30  
Single Run 60

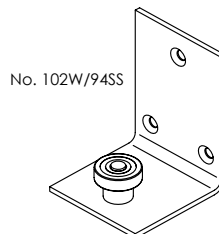

No. 102W/94SS

**Alternative guide**  
Single Run 80/100  
Zero Clearance 80/100

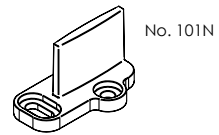

No. 101N

**Alternative saw cut guide**  
Sprintline 30  
Wardrobe Single & Double 50  
Single Run 60/80/120  
Zero Clearance 60/80/120

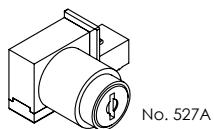

No. 527A

**Optional lock**  
Glassroll 30

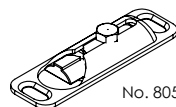

No. 805

**Alternative floor bracket**  
Multifold 30

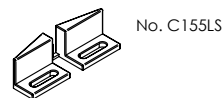

No. C155LS

**Cavity guide**  
Single Run 80/100  
Zero Clearance 80/100



No. C153B

**Cavity buffer**  
Single Run 60/80/100  
Zero Clearance 60/80/100

Call Brio for further details on Locks and Pulls

# Set Specifier

	Application			Operation			System Dimensions		Accessories		Fixing	
	Wardrobe Cupboard	Room Divider	Pocket Door	Bi-parting	Bypassing	No. of Panels	Max. Panel Weight	Max. Opening Size	Pelmet	Soft Close	Soffit	Face
<b>Folding</b>												
Bifold 16	●	●				2	16kg	2500mm			●	
Multifold 30	●	●				6	30kg	3900mm			●	
<b>Top Hung Sliding</b>												
Sprintline 30		●		●		1	30kg	2400mm	●			●
Wardrobe Single 50		●		●		1	50kg	1800mm	●		●	●
Wardrobe Double 50	●			●	●	3	50kg	2400mm			●	
Single Run 60		●	●	●	●	1	60kg	3000mm	●	●	●	●
Zero Clearance 60		●	●	●	●	1	60kg	3000mm	●	●	●	●
Single Run 80 & 100		●		●	●	1	100kg	3000mm		●	●	
Zero Clearance 80 & 100		●		●	●	1	100kg	3000mm		●	●	
<b>Bottom Rolling Sliding</b>												
Glassroll 30	●				●	2	30kg	1800mm				



# Brio®

Brio – Australia

PO Box 604, Chester Hill, 2162  
C5 - C7, Regents Park Estate, 391 Park Road,  
Regents Park, NSW 2143, Australia  
Phone +61 2 8718 6718 Fax +61 2 8718 6719  
[www.brio.com.au](http://www.brio.com.au)  
email: [brío.sales@allegion.com](mailto:brío.sales@allegion.com)

Brio – UK

Unit 30 Gateway West, Kingfisher Boulevard, Newburn Riverside,  
Newcastle Upon Tyne, NE15 8NZ, United Kingdom  
Phone +44 (0) 191 2291224 Fax +44 (0) 191 2677891  
[www.briouk.com](http://www.briouk.com)  
email: [brío.sales.uk@allegion.com](mailto:brío.sales.uk@allegion.com)

Brio – USA

85 Mushroom Blvd  
Rochester, NY 14623-3201  
Toll Free +1 855 586 6251 Phone +1 585 319 5599 Fax +1 585 319 5741  
[www.brioussa.com](http://www.brioussa.com)  
email: [brío.sales.usa@allegion.com](mailto:brío.sales.usa@allegion.com)

## About Allegion

Allegion (NYSE: ALLE) is a global pioneer in the field of safety and security. We keep people and their property safe, wherever they are, bringing together simple solutions and advanced technology. Allegion is a \$2 billion company, with products sold in almost 130 countries. For more, visit [www.briouk.com](http://www.briouk.com)

