

## Armco Fishtail Safety End

Designed to replace traditional steel fishtails to terminate Armco Safety Barrier with hi-visibility Polymer ends – promoting safety and awareness across your industrial facility.

Flexible on impact to eliminate the buckling of steel versions.

Highly visible to Artic Trailers reversing and transiting across service yards.



## Product Features

Designed to provide a safe termination to Armco

Ideal for covering sharp Armco cut ends

Provides added visibility for HGV drivers, forklift operators and car owners

Flexible upon impact with little-to-no vehicle damage

Full retrofit compatibility with all steel Armco ends

## Technical Details

Suits Armco 310mm x 85mm corrugated rails

Bolt fix secured with 4 No. M16 x 35mm bolt-set (to suit pre-holed Armco rail)

Supplied in Yellow for HGV and service yard areas

Supplied in Black for domestic vehicle and front-of-house areas

## Product Specification

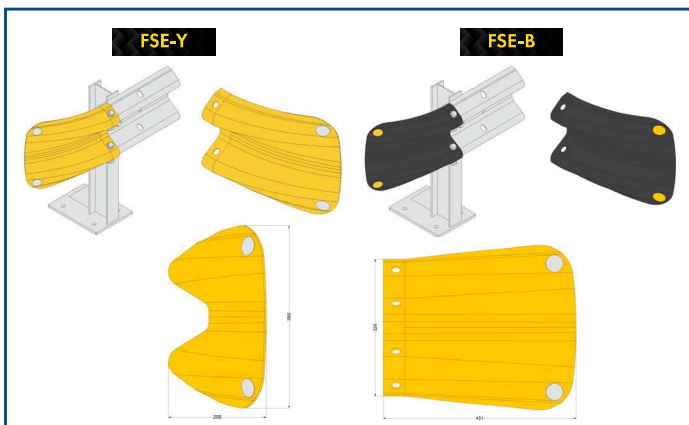

<b>Material</b>	Polyethylene (M/HDPE)
<b>Polymer formula</b>	Colour-Fast/UV Package
<b>Recycling group</b>	PE/4
<b>Manufactured</b>	UK
<b>Height</b>	320mm to suit 310mm x 85mm Armco Rail
<b>Colour options</b>	Yellow with Silver Diamond Grade Reflectors or Black with Yellow Diamond Grade Reflectors
<b>Fixings</b>	4 no. M16 x 35mm Galvanised Bolt Set (NOT included)
<b>Safety reflectors</b>	2 no. 40mm Diamond Grade Reflectors