

Instruction Card

Winglock 900

Maintenance

- Caution!** Do not use water near the drive unit and controls.
- Warning!** Switch the power supply off before carrying out any maintenance and / or other work on the Winglock.
- Weekly:** Clean the stainless steel surfaces with a damp cloth.
- Monthly:** Clean the stainless steel surfaces with a damp cloth and soft soap.
- Annually:** The Winglock needs to be serviced at least once a year. This service and any repairs should be performed by Boon Edam B.V. or your dealer.

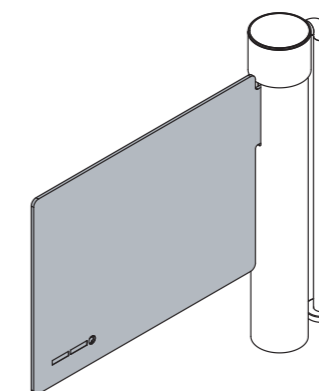











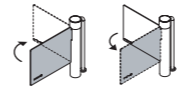

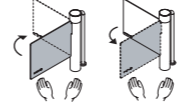

Winglock 900

Safety- and Operating instructions

Maintenance

Explanation of the symbols

	Door panel locked in closed position		Blocked in and out*
	Door panel will open or close		Alarm with acoustic signal*
	Door panel opens or closes manually / Failsafe		Alarm*
	No power supply		Door panel is locked
	Power supply		Door panel is unlocked
	Acoustic pulse signal*		Action after 3 seconds (adjustable from 2 -10 seconds)
	Authorisation to allow a person in or out* (Button pressed, door panel stays open)*		Option



Check the emergency- and safety devices and the general operation of the Winglock daily!

Dealer:

For further information, consult the operating manual.

Boon Edam B.V. Postbox 40, 1135 ZG Edam Holland.

Version : 2014/01/22
Issue : WL900-INS-UK

Safety- and Operating instructions

A Safety device

1 Failsafe

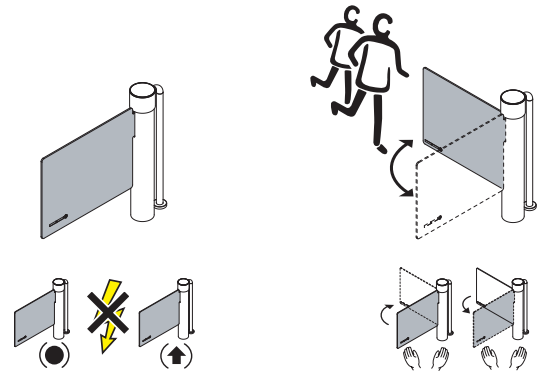

2 Fire alarm

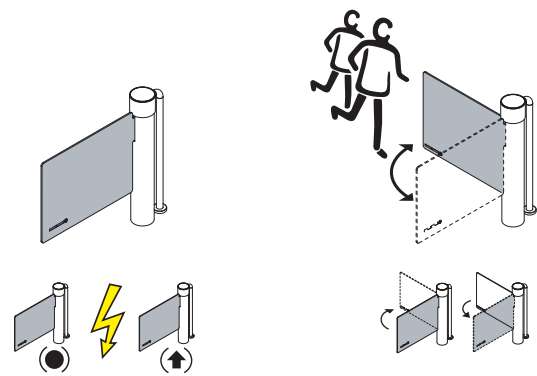

3 Block detection

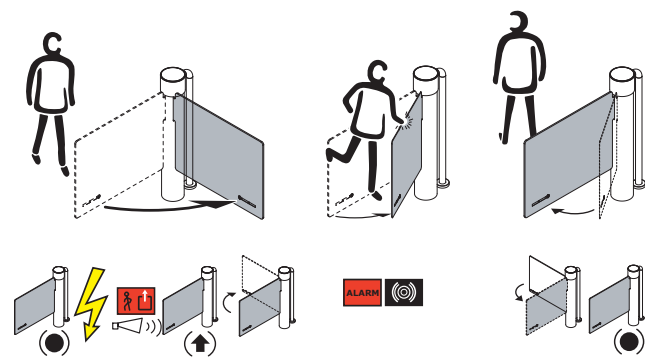

B Control panel*

1 Pulse in

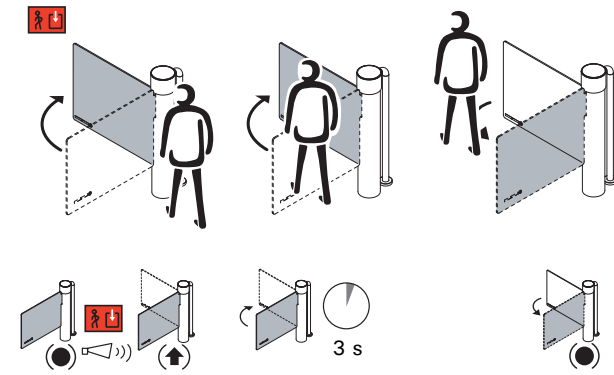

2 Pulse out

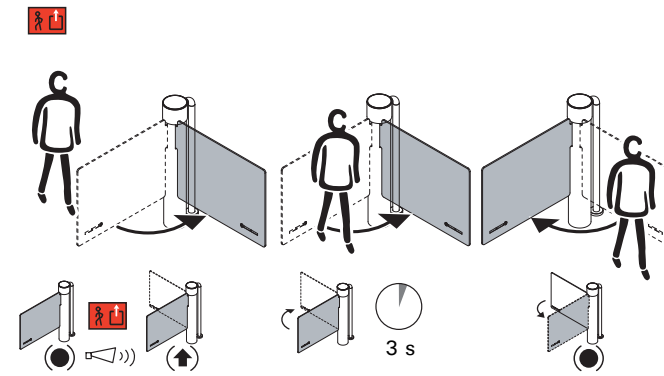

3 Locked

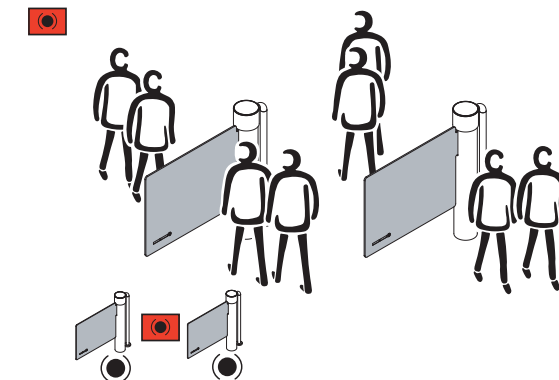

4 Open (continuous pressed)

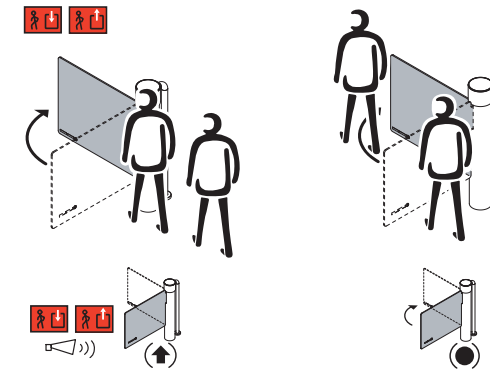

5 Alarm

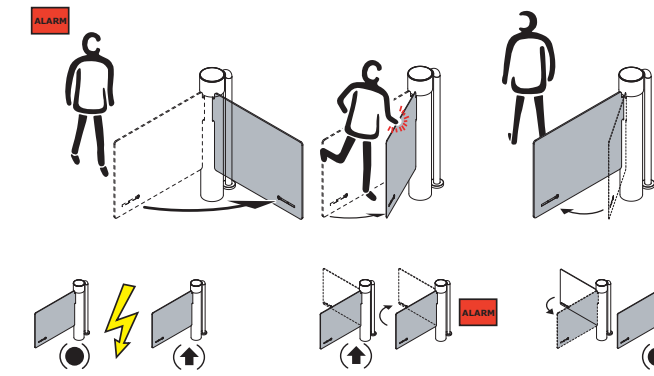

C Authorisation

1 Card reader on pedestal*

