

FIREROLL VR60

Insulated Rolling Fire Shutters

Bolton Gate Company, the leader in the field of rolling fire door technology, introduces Fireroll VR60, a revolutionary product designed to provide 60/60 minutes fire protection between individual compartments. The door has been successfully tested to EN 1634-1 for one hour integrity and insulation and is therefore rated "EI60".

Up to the present time, the insulation requirement of a fire door was only met by unsightly hinged or sliding products with thick panels and the disadvantage of their associated space requirements. Due to the unique design of the Fireroll VR60, the product has all the advantages of a rolling fire product which can be stored above the false ceiling whilst meeting the requirements of both integrity and insulation in line with the latest building regulations.



STANDARD SPECIFICATION

Curtain

The curtain is constructed from 63 x 36mm laths comprising a synthetic material outer skin bonded to a special inner core consisting of high performance insulation materials.

Stainless steel cables connected the laths together and are fastened to the roller at the head

The bottom rail comprises a standard lath fitted with an extruded PVC bottom seal.

Guides

Manufactured from galvanised steel and formed into a channel profile which is prepared for bolting to the structure by means of continuous fixing angles.

Head

A combination of galvanised steel and 'u' profile and MDF board with a special fire protection cover is fixed to the lintel into which the top of the door engages providing an effective seal against the passage of flames and hot gases.

End Brackets

Fabricated from galvanised steel of adequate thickness relative to door size and supplied with steel plates for fixing to the structure.

Roller

The roller comprises a steel tube of adequate diameter and wall thickness to avoid deflection. Steel shafts and discs are inserted at each end and the whole assembly is supported at each end on the end brackets.

OPERATION

Suitable for all sizes of shutters, the Speedsafe drive unit has a 415 volt 3 phase geared induction motor with an electromagnetic brake, limit switches and a fusible link. The design provides a fail-safe system which will close the shutter automatically in the event of a fire situation.

A controlled descent of approximately 100mm per second is an inbuilt safety feature.

Manual operation in the event of a power loss is achieved by releasing a pull cord to close the shutter under controlled descent and a hand chain to open. Each fire shutter is individually operated from a control station, incorporating open / close / stop push buttons positioned adjacent to the shutter guide.

A 24 volt DC auto reset solenoid is available for linking into the fire alarm or BMS.

FINISH

The curtain is self finished light grey with the perimeter intumescent seal in black.

WEIGHT

Approximately 50 kgs per square metre.

MAXIMUM SIZES

6 metres wide x 4 metres high

OPERATING SPEED

Approximately 100mm per second

FIREROLL VR60

Insulated Rolling Fire Shutters

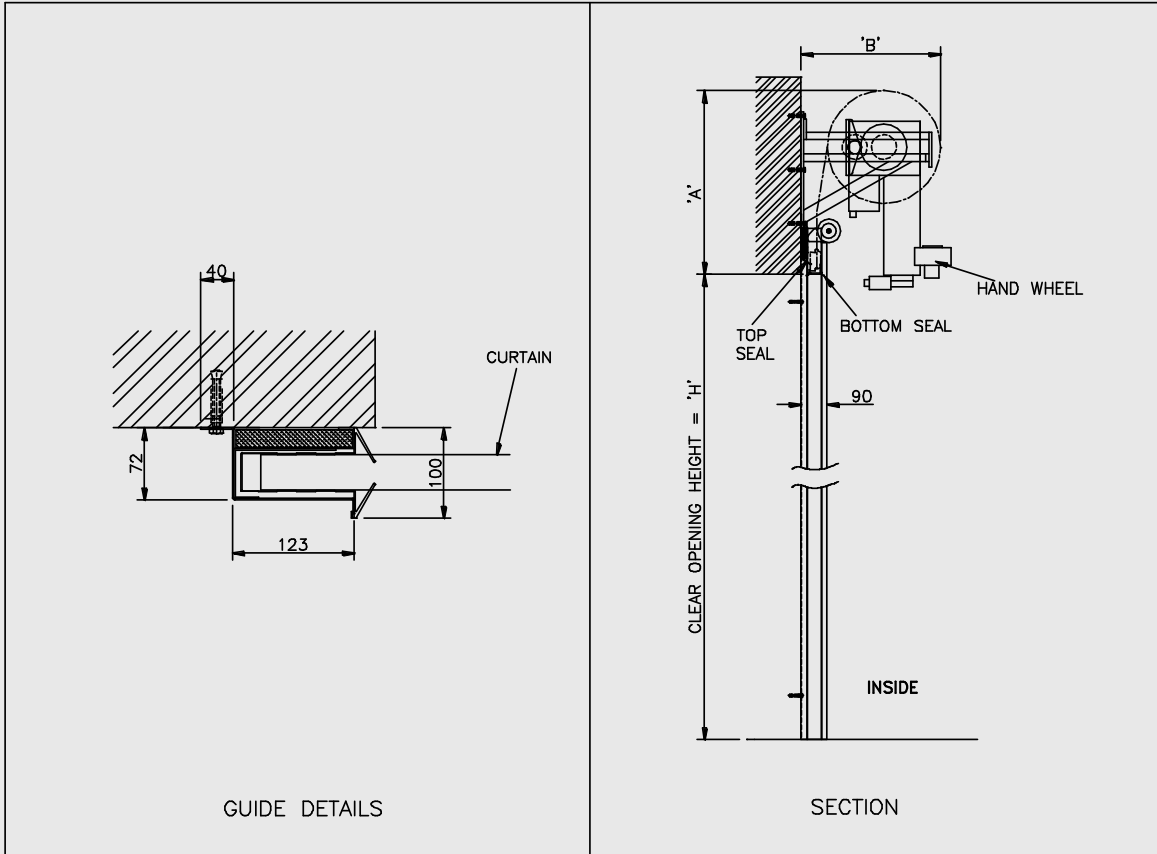

CLEAR HEIGHT (H)	'A'	'B'
2750	620	480
4000	660	590
5250	700	670
6500	740	770

