

FIREROLL E240

Fire Resisting Roller Shutters

Bolton Gate offers probably the most comprehensive range of modern fire resisting shutters available on the market today; products which satisfy the needs of large/complex packages as well as meeting the most stringent safety and insurance requirements. All Bolton Gate fire doors and shutters are tested and assessed by officially recognised and competent authorities.

Bolton Gate fire resisting roller shutters are designed for fire protection with durability and reliability in mind. Fireroll E240 is suitable for various installations including department stores, shopping centres, warehouses, factories and car parks. Fireroll E240 has been tested to BS476 Part 22 1987 and the latest EN 1634-1 for up to four hours' fire protection. Safety features of the Fireroll E240 include the Speedsafe gearbox which provides a controlled descent on receipt of a fire signal and a safety ratchet.

STANDARD SPECIFICATION

Curtain

Shutter curtains are constructed from continuously interlocked 76mm curved section steel laths which are securely held in place by end locks. Lath thicknesses vary from 0.7mm to 1.2mm dependent upon opening size. Bottom rails are galvanised and roll formed into a Tee section.

Guides

Channel section galvanised mild steel guides with slotted fixings for expansion in a fire are fixed to the jambs with continuous steel angles.

Endplates

Prime painted mild steel of appropriate thickness relative to door size.

Finish

Fireroll E240 is supplied with the majority of parts galvanised as standard. Where non-galvanised parts are utilised these are finished with one coat of primer paint.

ELECTRICAL OPERATION

Suitable for all sizes of shutters, the Speedsafe drive unit has a 240 volt 1 phase geared induction motor with an electromagnetic brake, limit switches, thermal release unit and a built-in starter panel.

The design provides a fail-safe system which will close the shutter automatically in the event of a fire situation and power loss. A controlled descent of approximately 100mm per second is an inbuilt safety feature.



Manual operation in the event of a power loss is achieved by releasing a pull cord to close the shutter under controlled descent and a hand chain to open. Each fire shutter is individually operated from a control station, incorporating three push buttons positioned adjacent to the shutter guide. Larger shutters are provided with 400 volt 3 phase motors.

MAXIMUM SIZES

General assessment: 7 metres wide x 7 metres high
Individual assessment: 12 metres wide x 8 metres high

SPEED OF OPERATION

Speedsafe controlled descent approximately 100mm per second, dependent on size of shutter.

WEIGHT

Varies with opening size dependent on lath/barrel/casing requirements but approximately 50kgs/m².

OPTIONS

- Heat/smoke detectors
- Audio visual warning
- Polyester powder coated finish in a range of standard RAL colours.
- Auto reset solenoids
- Auto reset magnets

FIREROLL E240

Fire Resisting Roller Shutters

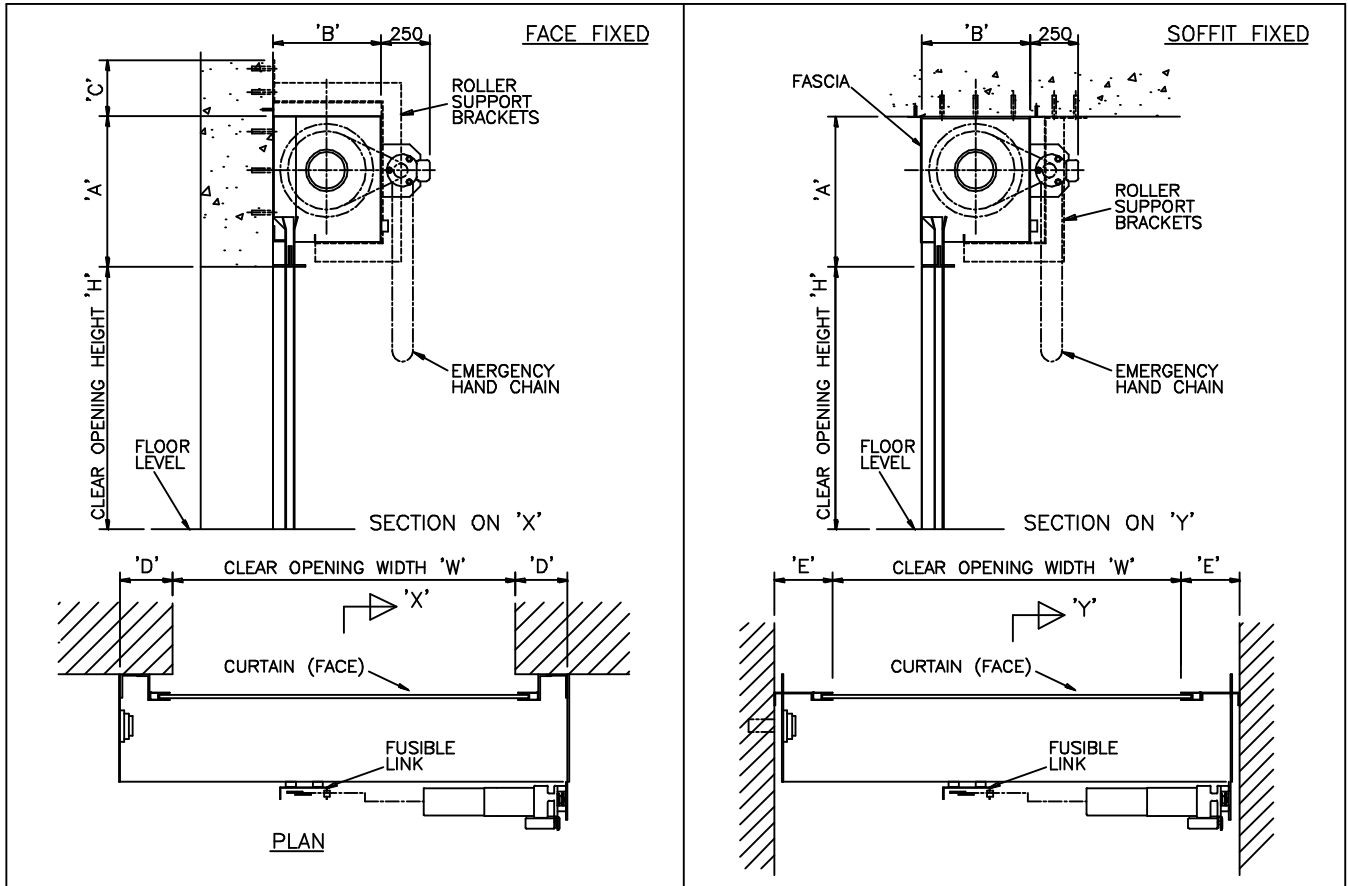

'H'	ENDPLATE RANGE					
7000	4	4	4	4	4	5
6000	4	4	4	4	4	5
5000	3	3	3	3	4	5
4000	2	2	2	3	3	3
2600	1	1	1	3	3	3
'W'	2200	3000	4000	5000	6000	7000

	'A'	'B'	'C'	'D'	'E'	'F'
5	680	525	295	200	225	190
4	630	475	265	200	225	190
3	560	420	265	200	225	190
2	560	420	265	150	175	140
1	520	345	265	150	175	140

GUIDE DETAILS

FACE FIXED TO MASONRY

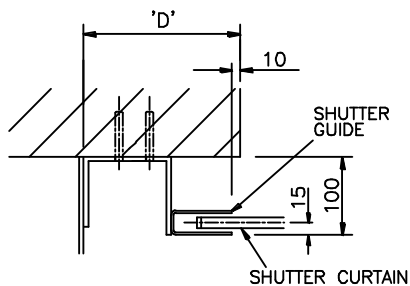

FACE FIXED TO STEEL

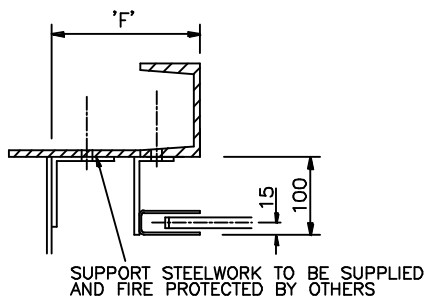

SIDE FIXED TO MASONRY

