

EUROFOLD

Fire Resisting Folding Shutters

Bolton Gate's Eurofold fire-resisting folding shutter has been tested extensively in accordance with BS 476 Part 22 1987 and BS EN 1634-1 for up to four hours fire resistance. Its compact folding action allows the widest of openings to be covered and coupled with its low headroom requirement, the Eurofold door has significant advantages over vertically moving doors.

The door is available in a single or pair configuration and has been successfully installed in thousands of buildings worldwide

STANDARD SPECIFICATION

Gate Frame

The gate frame is constructed from unique double channel vertical pickets made from galvanised steel interconnected by 2mm thick galvanised rolled section lattice bars.

The gate frame is top hung from ball-bearing pulleys connected to the pickets by zinc-plated pulley brackets. At the base, the frame is fitted with zinc-plated guide pieces designed to run in a bottom track.

Leading Edge

Roll-formed galvanised steel 117mm wide prepared for locks and fitted with Number 10 bow handles. Connection to the drive chain on electric doors is affected at the top of the leading edge.

Shutter Leaves

The shutter leaves are rolled from galvanised steel and are available in the standard width of 229mm with 152mm and 305mm versions also available.

Top Track

The standard top track from which the shutter is suspended is constructed from two galvanised steel sections 90mm deep, bolted together to give a strong smooth running section for the shutter thus minimising friction.

Bottom Track

A galvanised bottom track is supplied as standard within which the bottom guides run. An anti-sway version is available which negates the need for a bottom track where an unbroken floor surface is preferred.

OPERATION

Manual operation

Manually operated doors are suitable for smaller openings or where operation is either infrequent or only in a fire condition and are supplied in a single-leaf arrangement with activation in the event of fire via drop weights and a fusible link or 24 volt DC holdback magnet



Electric operation

Suitable for all sizes of opening, electric operation is achieved by a 415 volt 3 phase geared motor mounted on the top track with a fire relay included within the control panel to receive a 24 volt DC fire signal from the BMS or Fire Alarm. A maintained and protected AC supply is required for this version.

MAXIMUM SIZES

20 metres wide x 7 metres high.

FINISH

Mainly galvanised with other parts prime painted.

WEIGHT

Approximately 35 kgs per m².

OPTIONS

- Manual or electric operation
- Vision panel
- Choice of fire activation
- Polyester powder coating

EUROFOLD

FIRE RESISTING EUROFOLD DOOR – TECHNICAL DETAILS

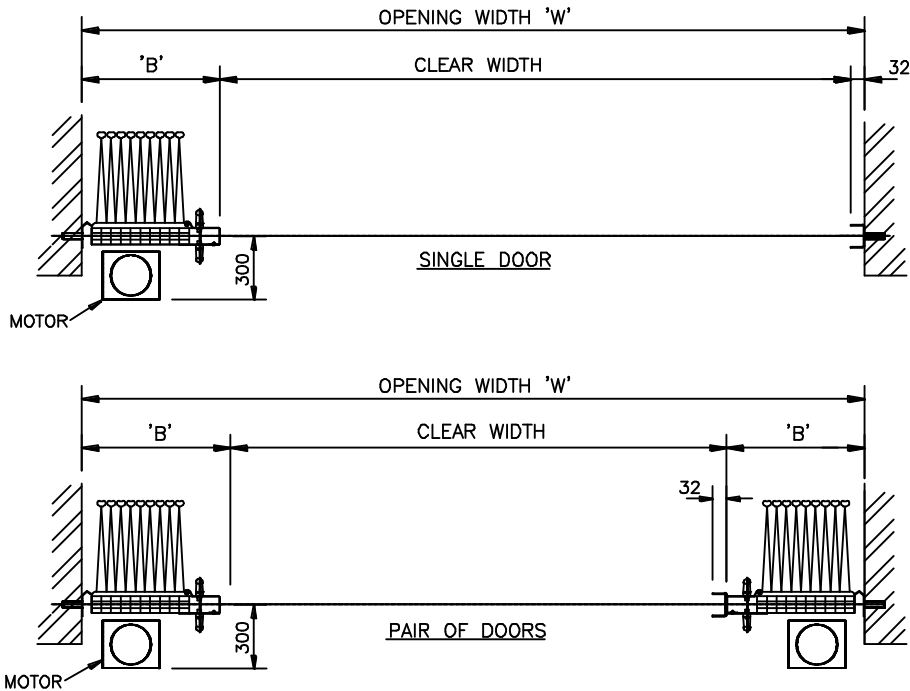

SINGLE DOOR		PAIR OF DOORS	
OPENING WIDTH 'W'	BUNCH 'B'	OPENING WIDTH 'W'	BUNCH 'B' (EACH SIDE)
UP TO 576	171	UP TO 1152	171
UP TO 1008	198	UP TO 2016	198
UP TO 1440	225	UP TO 2880	225
UP TO 1872	252	UP TO 3744	252
UP TO 2304	279	UP TO 4608	279
UP TO 2736	306	UP TO 5472	306
UP TO 3168	333	UP TO 6336	333
UP TO 3600	360	UP TO 7200	360*
UP TO 4032	387	UP TO 8064	387*
UP TO 4464	414	UP TO 8928	414*
UP TO 4896	441	UP TO 9792	441*
UP TO 5328	468	UP TO 10656	468*
UP TO 5760	495	UP TO 11520	495*
UP TO 6192	522	UP TO 12384	522*

* ON ELECTRIC DOORS ADD 50 TO DIM. 'B'

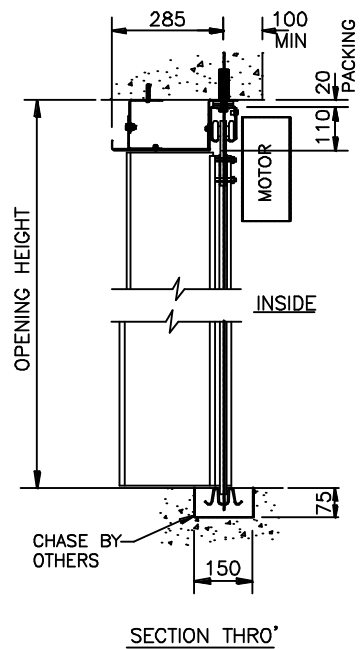

ALL DIMENSIONS IN mm