

CONTOUR 2000

Laterally Operated Fire Resisting Roller Shutters

Contour 2000 is an electrically operated lateral rolling shutter independently tested at Warrington Fire Research Centre to BS476 Part 22 for up to 4 hours fire resistance.

Contour 2000 is purpose designed to negotiate bends, curves, ovals and circles. This ingenious system combines total design flexibility with complete reassurance. Contour 2000 is the well-proven fire barrier which eliminates the need for unsightly piers that support vertical shutters and is therefore ideal for large open plan areas and atrium constructions. It is also the ideal product to cover large distances without the use of a bottom track. Architects and designers can achieve optimum use of space with an effective yet unobtrusive solution to fire separation. Its lateral motion makes Contour 2000 particularly suitable for large retail developments and department stores.

STANDARD SPECIFICATION

Curtain

The shutter curtain is constructed from curved section interlocking galvanised laths. The leading edge of the single shutter is led into a bell mouth receiving channel at the closing jamb whilst the leading edges of a pair of shutters are provided in male and female sections to effect an overlapping seal.

Suspension

The shutter laths are suspended from a narrow 200mm deep fabricated top track by means of ball bearing pulleys. The top and bottom of the curtain are attached to a heavy duty drive chain which provides the flexibility to follow contoured tracking arrangements. The top track can be fixed directly to the ceiling slab or a structural downstand or can be supported from hanger brackets permitting the passage of building services through a void which requires fire stopping generally by site contractors.

Shutter Box

The shutter curtain is mounted onto a patented constant-tension barrel assembled in a self-contained vertical fire resistant housing. A removable panel to one side of the housing permits access for maintenance.

Drive Systems The Contour shutter is provided with a 400 volt 3 phase 50 Hz motor gearbox with electromagnetic brake suitable for operation by direct on-mains or by instantaneous automatic changeover standby generator (by others) in case of power failure.

Emergency operation is achieved by high level crank handle operation of the motor shaft for which access is to be detailed by the architect.

Auxiliary Drive Unit

For shutters with complicated or long track configurations, a patented Auxiliary Drive Unit (ADU) is fitted at a significant position on the top track.

NORMAL OPERATION

The close button has constant pressure control whilst the open push button requires only momentary pressure to open the shutter.



FIRE CONDITION OPERATION

Activation in a fire condition is via a signal from the client's fire alarm or building management system.

MAXIMUM SIZES

General Assessment

Single: 30 metres wide x 4.5 metres high
Pair: 60 metres wide x 4.5 metres high

Individual Assessment

Single: 50 metres wide x 6 metres high
Pair: 100 metres wide x 6 metres high

SPEED OF OPERATION

Approximately 12 metres per minute.

FINISH

Contour shutter curtains and boxes are provided galvanised. The top track and hangers are prime painted.

WEIGHTS

Shutter box: 450kgs per linear metre of height
Curtain: 24kgs per m²
Track: 30kgs per linear metre of width

OPTIONS

- Polyester powder coated finish in a range of standard RAL colours
- Safety edges
- Audible and visual alarms

CONTOUR 2000

Laterally Operated Fire Resisting Roller Shutters

TECHNICAL DETAILS

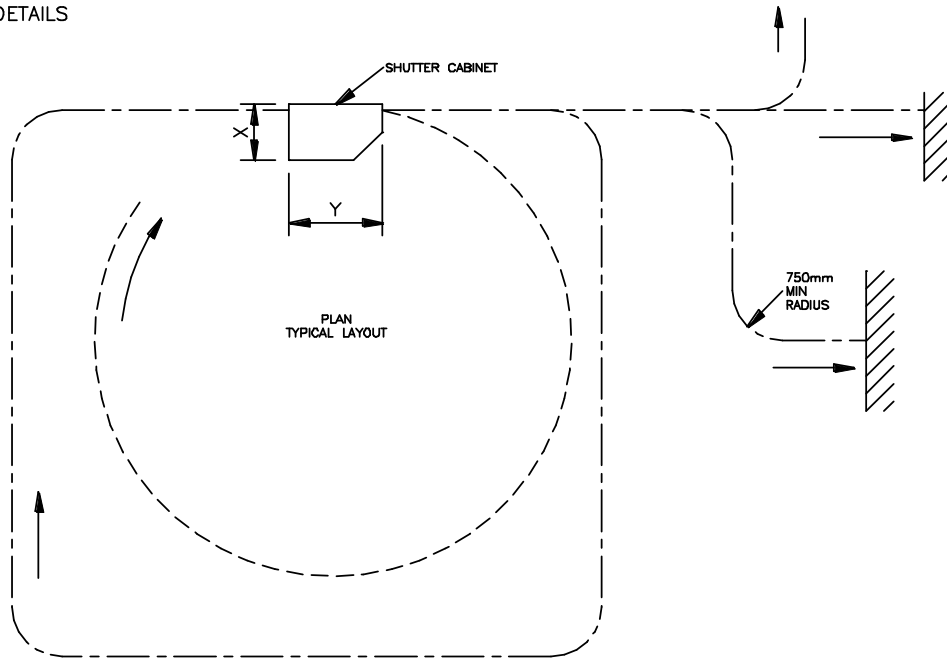

INFINITE VARIATIONS ACCEPTABLE FOR SINGLE & PAIR OF CURTAINS

CURTAIN LENGTH		UPTO 10M	UPTO 15M	UPTO 20M	UPTO 30M	UPTO 40M	UPTO 50M
BOX SIZES	X	750mm	850mm	950mm	1200mm	1300mm	1500mm
	Y	1300mm	1400mm	1500mm	1900mm	2000mm	2200mm

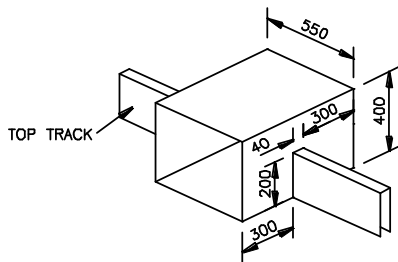

SPACE REQUIREMENTS FOR ADU

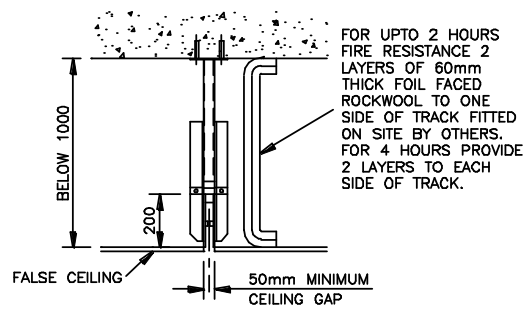

TRACK SUPPORT BRACKET UNDER 1000mm

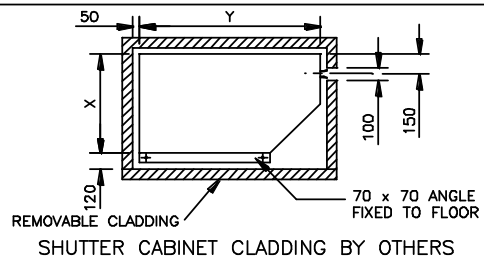
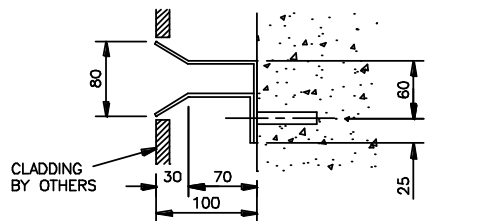

ALL DIMENSIONS IN mm