

# Manchester ( Solar Pathfinder ) Bollard

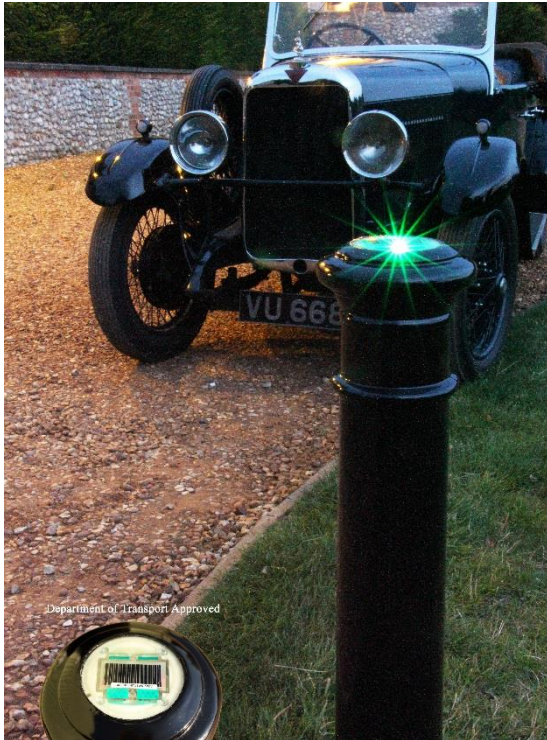

## DETAILED DESCRIPTION:

The Manchester SP Bollard requires no electrical installation or wiring. The solar powered light charges during the day and stays illuminated all night, giving visibility up to 900 metres. The solar light has been approved by The Department of Transport and is guaranteed for 10 years.

Available with a choice of white, red, green, blue and amber lights.

Inner structural steel core, engineering grade polymer manufactured from renewable sources. Highest quality UV filters and high performance two part polyurethane paint.

All our polyurethane products are virtually maintenance free and environmentally friendly.

## PRODUCT SPECIFICATION:

961mm above ground  
300mm below ground  
220mm at widest point

No wires  
Solar powered light  
Guaranteed for 10 years  
Unaffected by water (IP68 compliant)  
Solar Light approved by Department for Transport  
Available with white, red, blue, amber or green light  
Root fixed, bolt down or removable  
Ram raid deterrent option  
Choice of RAL colours  
Option of reflective and painted bands

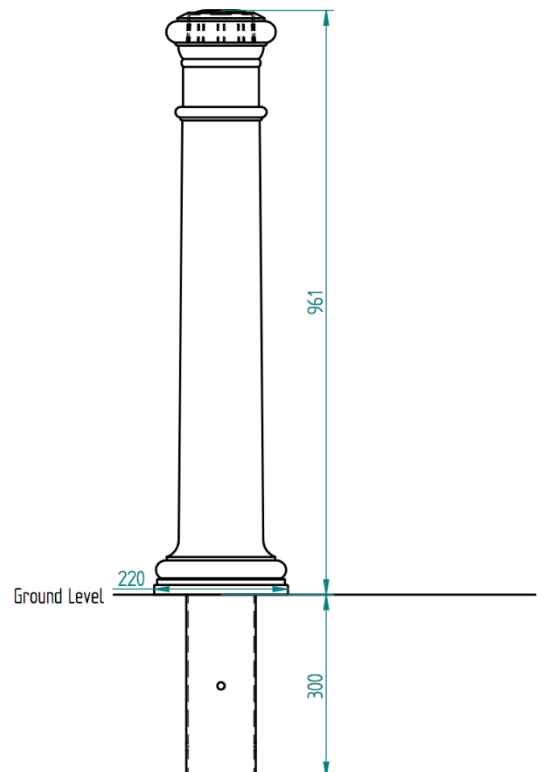

[sales@bollards-international.com](mailto:sales@bollards-international.com)

**Bollards International**

Station Road, Roydon, King's Lynn, Norfolk, PE32 1AW Tel: 01485 601145 Fax: 01485 601144 [www.bollards-international.com](http://www.bollards-international.com)

Manufacturers of Enviro-Cast™ Street Furniture

# Manchester ( Solar Pathfinder ) Bollard

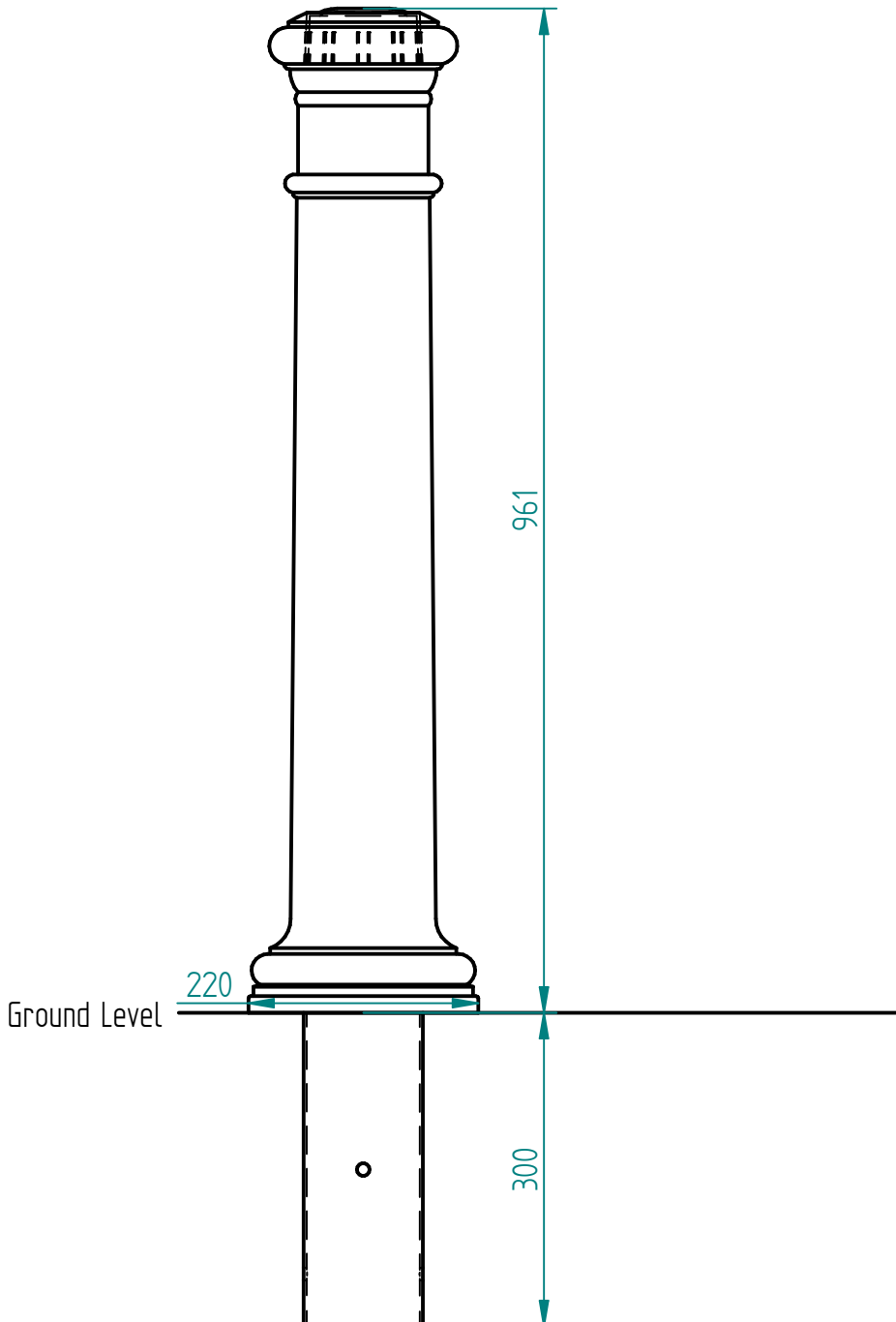

**Measurements:**

961 mm above ground  
300 mm below ground  
220 mm at widest point

**Fixings:**

Root, bolt down or removable

**Composition:**

Inner structural steel core,  
engineering grade polymer  
manufactured from renewable  
sources

**Finish:**

High performance, aviation  
grade, two part polyurethane  
paint. Available in any RAL  
colour

All our polyurethane products  
are virtually maintenance free  
and built to last

Steel Dia.	Scale	DATE
114.3 mm	1:7	10/29/14
UNLESS OTHERWISE SPECIFIED DIMENSIONS ARE IN MILLIMETERS		

[sales@bollards-international.com](mailto:sales@bollards-international.com)

**Bollards International**

Station Road, Roydon, King's Lynn, Norfolk, PE32 1AW Tel: 01485 601145 Fax: 01485 601144 [www.bollards-international.com](http://www.bollards-international.com)

Manufacturers of Enviro-Cast™ Street Furniture