

# Monarplan Application Manual

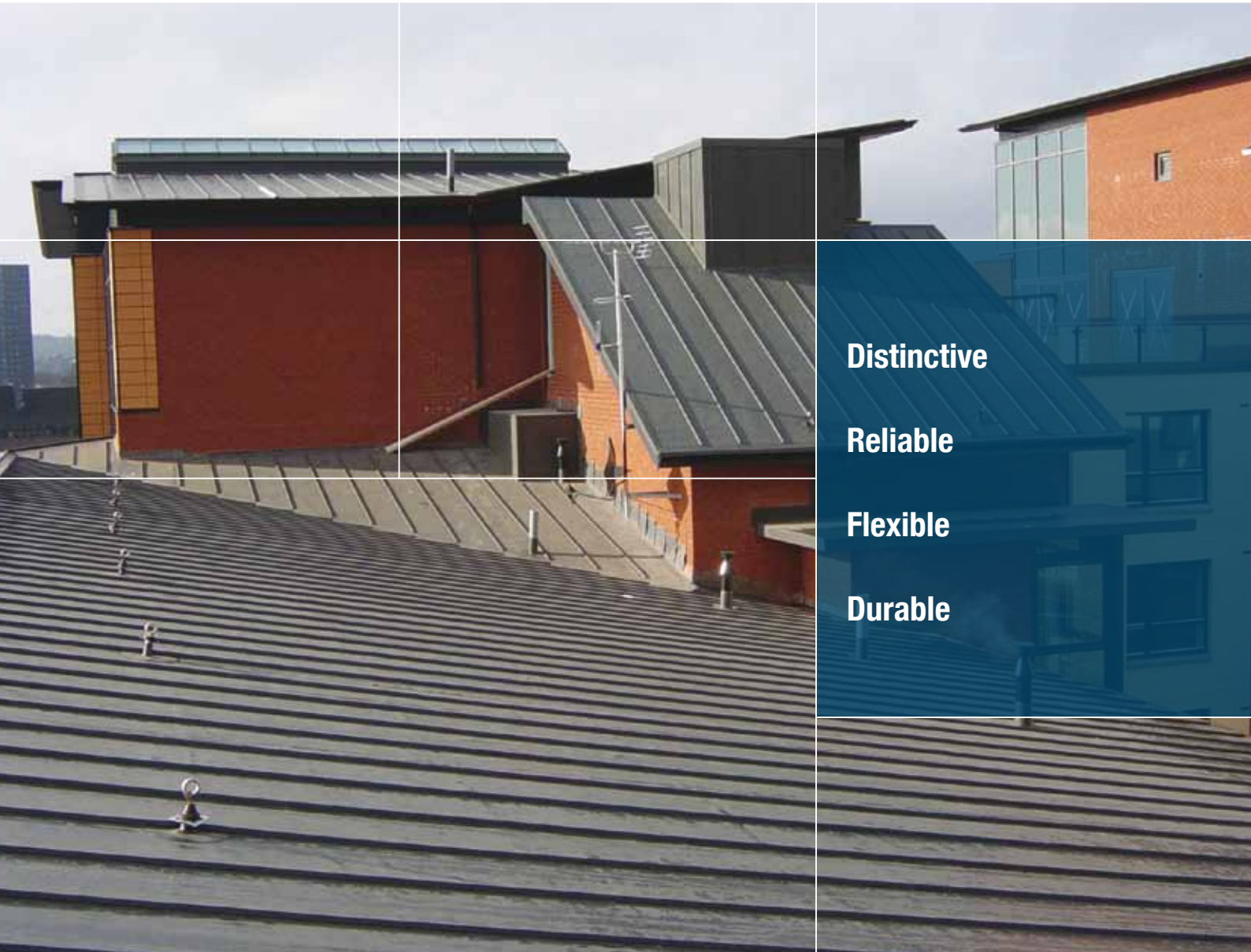

**Distinctive**

**Reliable**

**Flexible**

**Durable**

The standard for PVC roofs



Dear Sir / Madam

Thank you for your recent interest in Monarplan PVC synthetic single ply membrane system from Icopal.

To assist you in the future promotion of Monarplan PVC, we have created the following information pack covering all aspects of the product, including selection of the appropriate membrane, accessories and lots more.

Monarplan synthetic single ply roofing membrane comprises two layers of flexible polymer compounds (PVC-P) reinforced with either polyester or glass mesh. The resulting membrane offers excellent strength, elongation and weathering characteristics.

Monarplan PVC membranes and accessories deliver high performing, lightweight, flexible roofing systems which are easier, safer and quicker to install. Able to meet highly challenging design briefs, Monarplan PVC systems deliver excellent thermal performance and airtight construction, thereby reducing a building's carbon footprint whilst ensuring high quality waterproofing protection. Monarplan PVC membranes are suitable for all building sectors, including new build and refurbishment.

Should you require any further information, please refer to the contacts page enclosed within.

Yours sincerely,

A handwritten signature in black ink that reads 'S.D. Ashworth'.

Simon Ashworth  
*Product Manager*

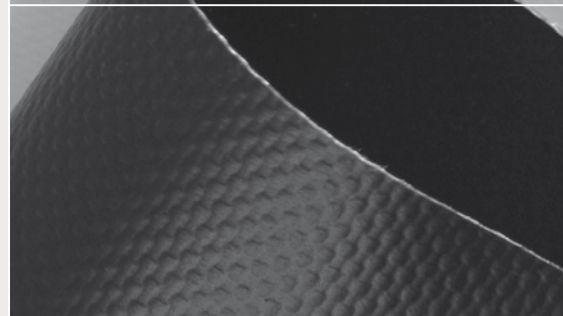
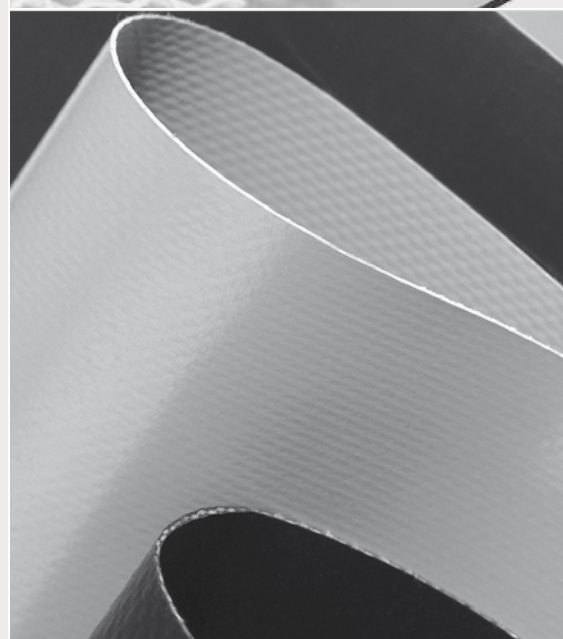
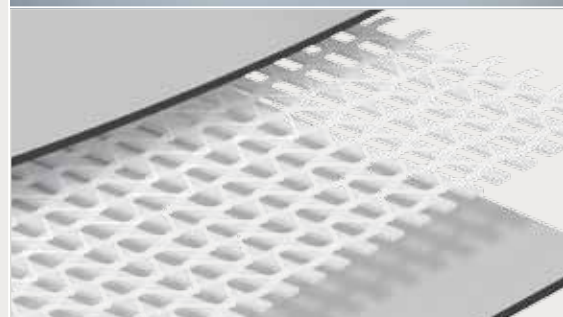

# Monarplan PVC Synthetic Single-Ply Roofing Membrane



## Features

- Monarplan has third party accreditation from BBA (10/4739) and ETA (08/0379).
- Monarplan membranes are flexible and easy to handle.
- Monarplan FM is available in different thicknesses – 1.2 / 1.5 / 1.8mm.
- Monarplan membranes are easy to hot air weld and fast to install.
- Monarplan can be mechanically fixed, fully adhered and/or loose laid & ballasted.
- Monarplan membranes are supported by insurance backed product warranties as standard for periods of 10, 15 & 20 years.
- Monarplan FM is available in a range of colours. Light grey is stocked as standard. Alternative colours are available with minimum order quantities.
- BBA certified life expectancy in excess of 30 years.
- Monarplan FM's polyester reinforcement is hydrophobic eliminating the possibility of wicking and the need for any liquid PVC along cut edges.
- UV Resistant.

## Why choose Monarplan?

- Monarplan PVC membranes physical characteristics are comparable to many of the current market leading PVC products. This allows Monarplan to compete on a like for like basis, whilst remaining competitive on price.
- Icopal have a long tradition of manufacturing quality PVC membranes for over 40 years.
- Icopal's PVC manufacturing capacity is now greater than 20 million square metres making Icopal one of the leading manufacturer's of PVC membranes in Europe.
- Monarplan membranes are complimented by a full range of compatible accessories making system specification much easier.
- Compatible with other Icopal product ranges.
- Sustainability: Monarplan PVC membranes achieve an A+ rating under the BRE's Green Guide when used above a metal deck.
- Monarplan PVC membrane production waste is recycled.
- Monarplan membranes can be used beneath green roofs.
- Monarplan is ideal for small domestic extensions or large commercial projects.



# Monarplan FM PVC Membrane



**Description:** 2 layers of PVC membrane reinforced with a polyester

**Application:** Mechanically fastened roof systems

**Membrane thickness:** 1.2 / 1.5 / 1.8mm

**Roll Size:** 1.5 x 20m (1.2mm), 1.5 x 15m (1.5mm & 1.8mm)

**Colour:**

- Light grey – RAL 7001(standard)
- White – RAL 9010\*
- Green – RAL 6004\*
- Anthracite – RAL 7015 (standard)
- Blue – RAL 5005\*
- Turquoise – RAL 5018\*
- Stone red – RAL 3011\*

\* Denotes special colours. Minimum order 3000m<sup>2</sup>

■ **Monarplan FM PVC Membrane  
(1.2 / 1.5 / 1.8mm)**

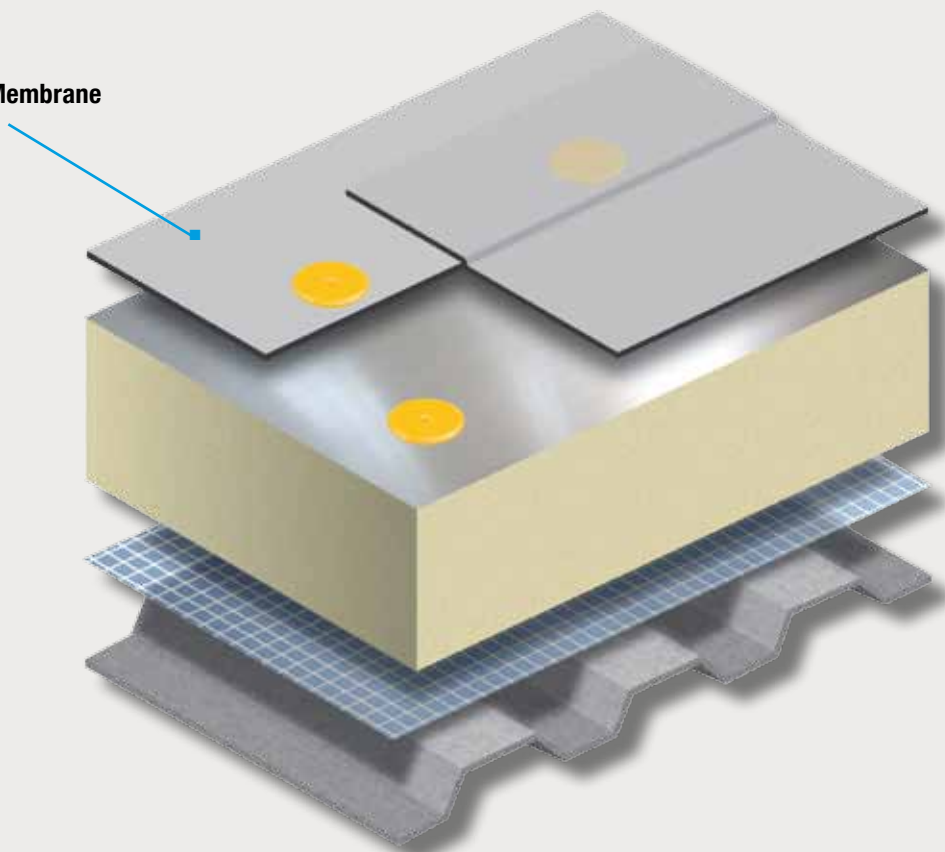

# Monarplan GF PVC Fleeceback Membrane



<b>Description:</b>	2 layers of PVC membrane reinforced with glass fibre and a polyester fleece on the underside
<b>Application:</b>	Fully adhered roof systems
<b>Membrane thickness:</b>	1.5mm + fleece
<b>Roll Size:</b>	2.12m x 15m
<b>Colour:</b>	Light grey – RAL 7001 Anthracite – RAL 7015

■ Monarplan GF PVC  
Fleeceback Membrane

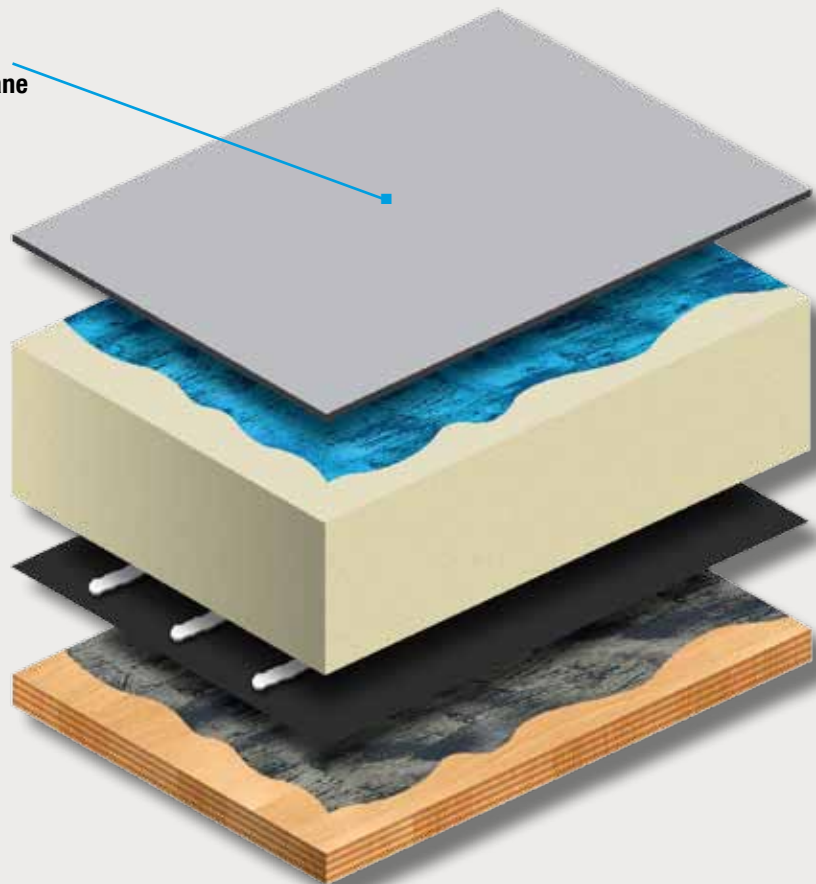

# Monarplan G PVC Membrane



<b>Description:</b>	2 layers of PVC membrane reinforced with glass fibre
<b>Application:</b>	Loose laid and ballasted roof systems
<b>Membrane thickness:</b>	1.5mm
<b>Roll Size:</b>	2.12m x 15m
<b>Colour:</b>	Light grey – RAL 7001

■ Monarplan G  
PVC Membrane

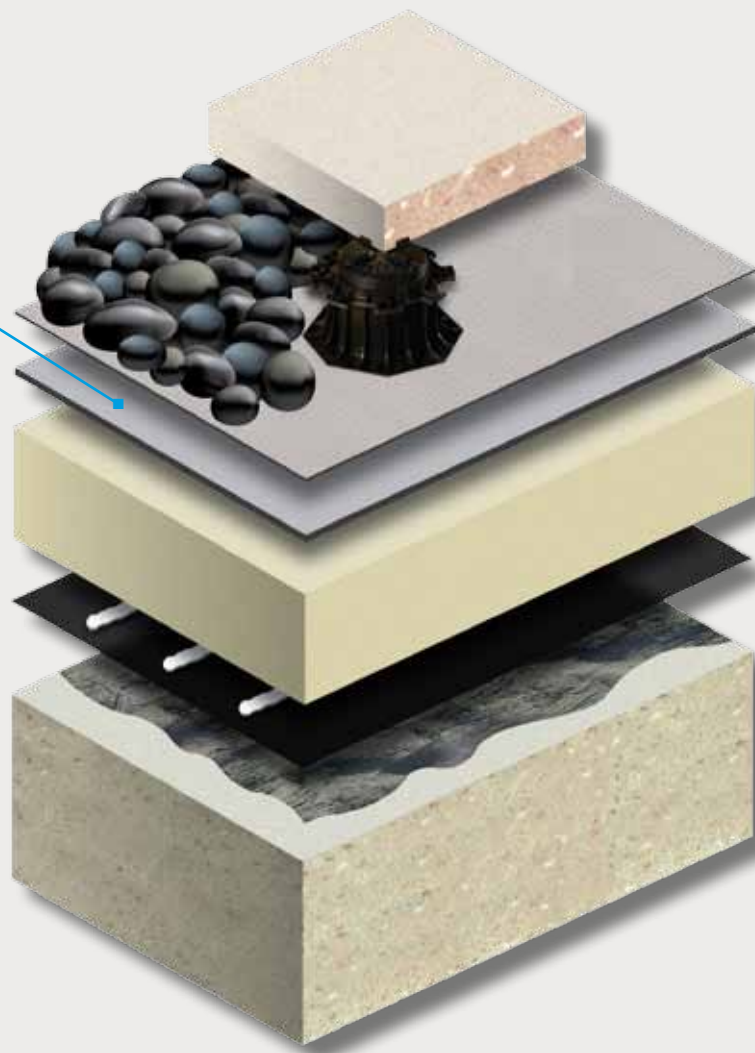

# Monarplan PVC Accessories



The standard for PVC roofs

# Monarplan PVC Accessories



## Monarplan Walkway Membrane

- Description:** A PVC anti-skid walkway membrane with a embossed tread to the upper surface
- Application:** Hot air welded to the Monarplan membrane
- Thickness:** 2.0mm
- Roll Size:** 1.06 x 15m
- Colour:** Dark grey



## Monarplan Reinforced Strip

- Description:** Monarplan FM cut into small rolls for use at end laps with Monarplan GF fleeceback membrane
- Application:** Hot air welded to the Monarplan membrane
- Thickness:** 1.5mm
- Roll Size:** 0.15 x 15m
- Colour:** Light grey & Anthracite

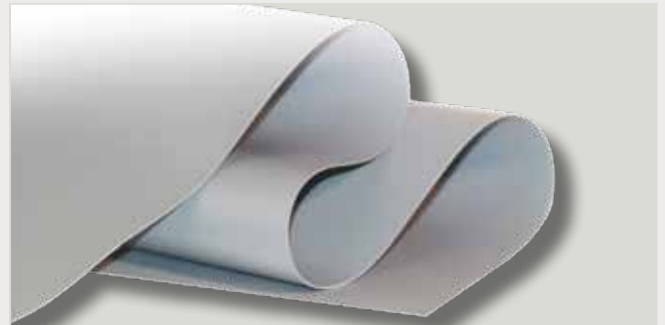

## Monarplan Coated Metal

- Description:** Monarplan coated metal is used to create drip edges, upstands and other details. The product is supplied in sheet form and fabricated by the contractor.
- Application:** Mechanically fastened
- Thickness:** 1.2mm
- Roll Size:** 1.0 x 2.0m
- Colour:** Light grey & Anthracite

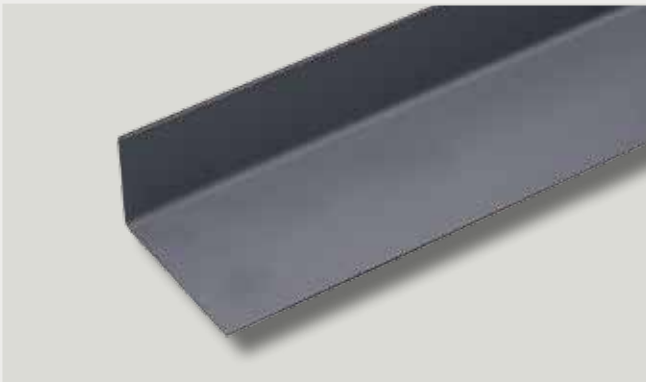

## Monarplan Pre-fabricated Corners

- Description:** Pre-moulded unreinforced Monarplan for use at Internal and external corners.
- Application:** Hot air welded to the Monarplan membrane
- Thickness:** 1.5mm
- Colour:** Light grey & Anthracite



# Monarplan PVC Accessories



## Monarplan Standing Seam

- Description:** Pre-moulded unreinforced Monarplan shaped to replicate a traditional rolled lead roof
- Application:** Hot air welded to the Monarplan membrane
- Length:** 3m
- Depth:** 25mm
- Colour:** Light grey & Anthracite

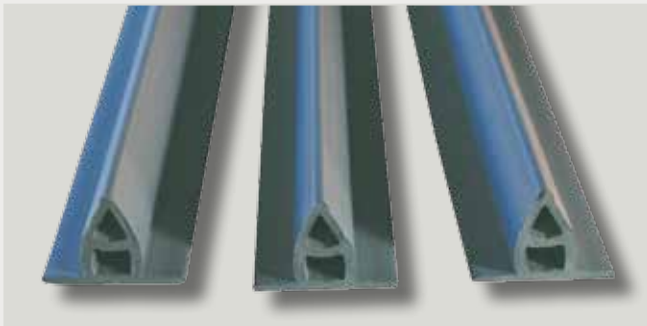

## Monarplan Lightning Conductor Clip

- Description:** Pre-moulded clips to receive lightning conductor cables
- Application:** Hot air welded to the Monarplan membrane
- Clip Size:** 3mm (bare cable), 5mm (coated cable)
- Pad Size:** 85mm
- Colour:** Light grey & Anthracite

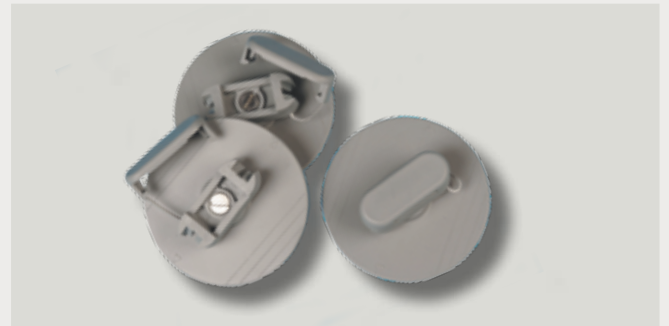

## Monarplan Roof Outlets

- Description:** Roof outlets of varying diameters incorporating an unreinforced Monarplan membrane flange and anti-backflow rubber gasket
- Application:** Mechanically fastened and Hot air welded to the Monarplan membrane
- Spigot Length:** 400mm
- Sizes:**  
50mm to fit 61-77mm downpipe  
70mm to fit 87-108mm downpipe  
80mm to fit 105-111mm downpipe  
125mm to fit 152-160mm downpipe
- Colour:** Light grey



## Monarplan Universal Leaf Grate

- Description:** A rigid plastic leaf grate with expanding clamps
- Application:** Adjustable screw clamp



# Monarplan PVC Accessories



## Monarplan Parapet Outlets

- Description:** Roof outlets of varying diameters incorporating an unreinforced Monarplan membrane flange
- Application:** Mechanically fastened and hot air welded to the Monarplan membrane
- Spigot Length:** 300mm
- Sizes:** 50mm/70mm/80mm/125mm/200mm
- Colour:** Light grey



## Monarplan Pipe Boots

- Description:** Pre-moulded unreinforced Monarplan pipe flashing. To accommodate pipe diameters from 50 – 125mm
- Application:** Hot Air Welded to the Monarplan membrane & jubilee clipped around pipe
- Size:** 50 – 90mm & 75 – 125mm
- Colour:** Light grey



## Monarplan Tube Washers & Fasteners

- Description:** A range of carbon and stainless steel fasteners Combined with polyamide tube washers
- Application:** Used for mechanically fastened membranes
- Fastener Size:** 35 – 300mm
- Washer Size:** 15 – 185mm



## Monarplan Fleeceback Adhesive

- Description:** A polyurethane based adhesive specifically for adhering fleecebacked membrane
- Application:** Applied to the surface only using a squeegee and roller
- Coverage:** 2 – 3m<sup>2</sup> / kg
- Tin Size:** 20kg
- Colour:** Dark blue



# Monarplan PVC Accessories



## Monarplan Contact Adhesive

**Description:** A solvent based instant contact adhesive used for adhering reinforced PVC membrane

**Application:** Applied to the surface and membrane using a squeegee & roller

**Coverage:** 1.5m<sup>2</sup> / kg

**Tin Size:** 20kg

**Colour:** Red



## Xtra-Seal Membrane Spray Adhesive

**Description:** A spray applied adhesive used to adhere fleecelined membrane

**Application:** Spray applied with spray equipment

**Coverage:** 5 – 7.3m<sup>2</sup> / kg

**Tin Size:** 13.6kg

**Colour:** Green



# Monarplan PVC Installation Manual

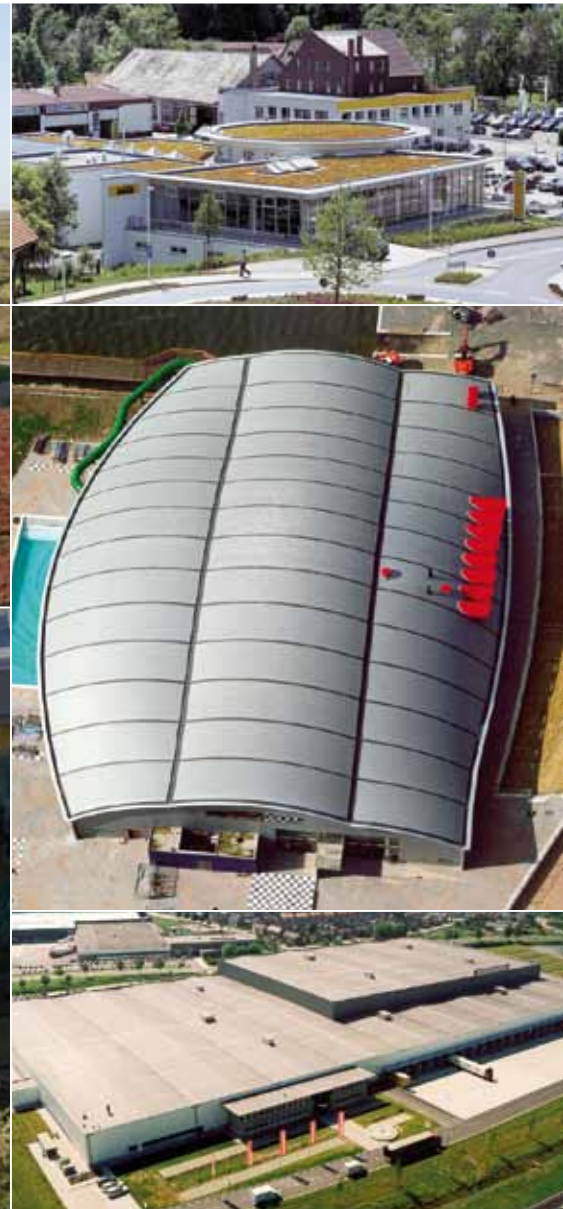

The standard for PVC roofs

# Monarplan PVC System Applications



## Mechanically fastened

- Monarplan FM membrane
- Monarplan washers & fasteners
- Thermazone foilboard insulation
- Icopal VCL

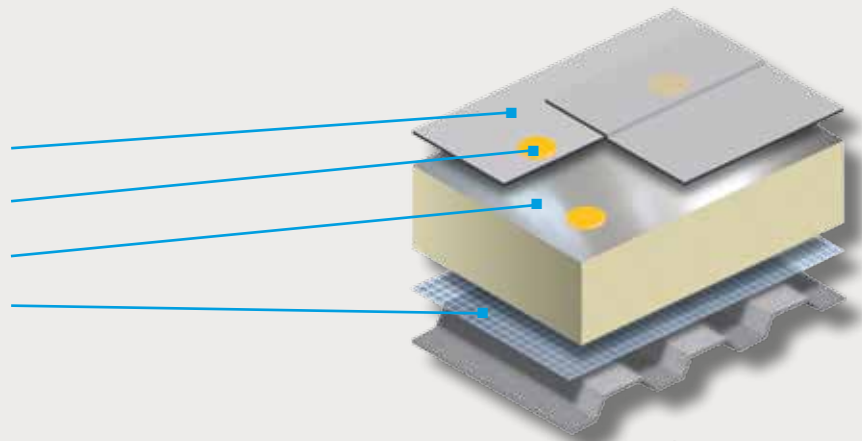

## Fully adhered

- Monarplan GF fleeceback membrane
- Monarplan fleeceback adhesive
- Thermazone roofboard insulation
- Icopal VCL

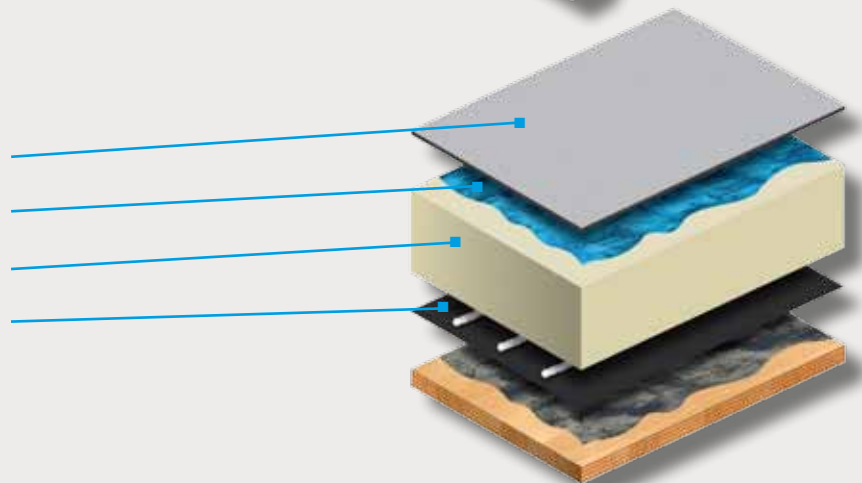

## Ballasted

- Filter / protection layer
- Monarplan G membrane
- Thermazone roofboard insulation
- Icopal VCL

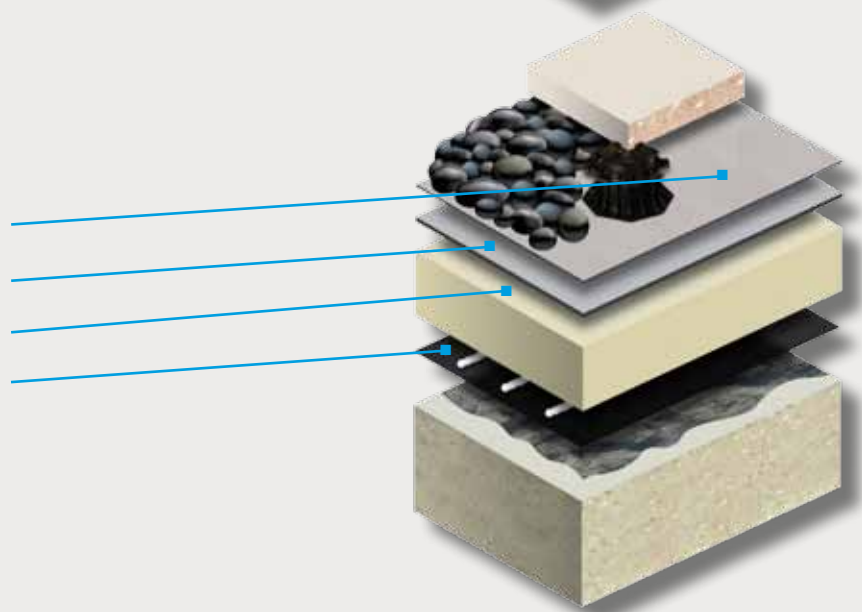

# Monarplan PVC System Applications



## Part mechanically fixed / part adhered

- Monarplan GF fleecelback membrane
- Monarplan fleecelback adhesive
- Thermazone roofboard insulation
- Icopal VCL

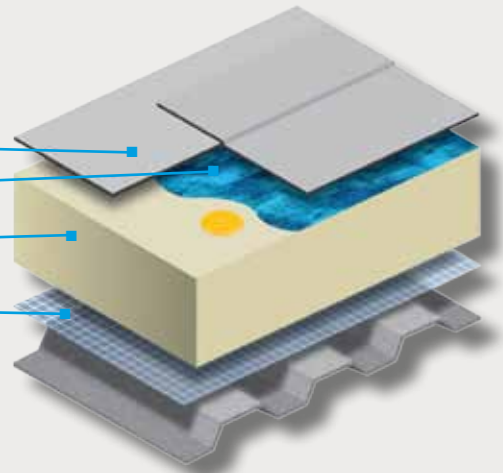

## Green roof

- Extensive green roof
- Filter / protection fleece
- Monarplan G membrane
- Thermazone roofboard insulation
- Icopal VCL

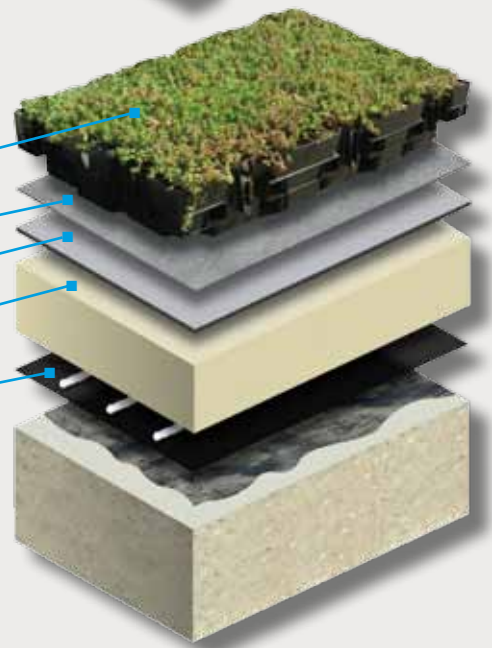

# Monarplan PVC

## Choosing the Right Membrane



### Step 1: Type of roof

Warm / Cold / Inverted / Refurbishment

### Step 2: Deck type

Plywood/OSB / Metal / Concrete / Timber boards / Other

### Step 3: Method of application

Mechanically Fastened / Fully Adhered / Ballasted / Combination

Warm roof	Mechanically fastened	Fully adhered	Ballasted	Mechanically fixed insulation fully adhered membrane
Plywood/OSB	Monarplan FM	Monarplan GF fleeeceback	Contact Icopal	Monarplan GF fleeeceback
Metal	Monarplan FM	Monarplan GF fleeeceback	Contact Icopal	Monarplan GF fleeeceback
Concrete	Monarplan FM	Monarplan GF fleeeceback	Monarplan G	Monarplan GF fleeeceback
Timber boards	Monarplan FM	Monarplan GF fleeeceback	Contact Icopal	Monarplan GF fleeeceback
Other	Monarplan FM	Monarplan GF fleeeceback	Contact Icopal	Monarplan GF fleeeceback

Cold roof	Mechanically fastened	Fully adhered	Ballasted
Plywood/OSB	Monarplan FM*	Monarplan GF fleeeceback	Contact Icopal
Metal	Not applicable	Not applicable	Not applicable
Concrete	Monarplan FM*	Not applicable	Monarplan G*1
Timber boards	Monarplan FM*	Not applicable	Contact Icopal
Other	Monarplan FM*	Contact Icopal	Contact Icopal

\* Polyester separation fleece should be laid above the substrate prior to attachment.

\*1 Polyester separation fleece should be laid between the concrete & membrane.

# Monarplan PVC

## Choosing the Right Membrane



Inverted Roof	Mechanically fastened	Fully adhered	Ballasted
Plywood/OSB	Not applicable	Not applicable	Monarplan G*
Metal	Not applicable	Not applicable	Not applicable
Concrete	Not applicable	Not applicable	Monarplan G*
Timber boards	Not applicable	Not applicable	Monarplan G*
Other	Not applicable	Not applicable	Contact Icopal

\* Polyester separation fleece should be laid between the substrate & membrane

Refurbishment	Mechanically fastened	Fully adhered	Ballasted	Mechanically fixed insulation fully adhered membrane
Plywood/OSB + old waterproofing	Monarplan FM*	Not applicable	Contact Icopal	Monarplan GF fleeceback
Metal + old waterproofing	Monarplan FM*	Not applicable	Contact Icopal	Monarplan GF fleeceback
Concrete + old waterproofing	Monarplan FM*	Not applicable	Monarplan G* <sup>1</sup>	Monarplan GF fleeceback
Timber boards + old waterproofing	Monarplan FM*	Not applicable	Contact Icopal	Monarplan GF fleeceback
Other	Contact Icopal	Not Applicable	Contact Icopal	Monarplan GF fleeceback

\* Polyester separation fleece should be laid above the substrate prior to attachment.

\*<sup>1</sup> Loading capability of existing structure to be confirmed.

### General description

The Monarplan membrane is comprised of two layers of polyvinylchloride (PVC) laminated to a polyester or glass fibre based reinforcement. The polyester reinforcement is coated with an oil inhibiting the wicking of moisture when exposed.

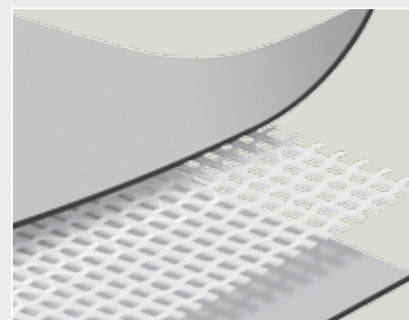

# Monarplan FM

## Mechanically Fastened



### Installation advice

Monarplan FM, polyester reinforced membrane relies upon mechanical fasteners and washers to restrain the membrane from wind uplift forces. Membranes are typically mechanically restrained along one edge with the adjoining membrane overlapping the fixing and welded to the underlying membrane with the application of hot air.

Install Monarplan FM, polyester reinforced membrane using Monarplan tubular washers and fasteners. For confirmation of the appropriate size of washers and fasteners to use, refer to appendix A. A wind uplift calculation and fastener specification will be required prior to installation of the Monarplan membrane.

Prior to and during membrane installation, inspect and correct the substrate; (i.e. voids or gaps, uneven conditions, and any other surface irregularities that can cause voids in the weld). Position sheets to allow for minimum 140mm side and 100mm end laps. In the case of the mechanically fastened systems the side lap should extend a minimum 60mm past the fastening plates / washers. The weld must have a minimum width of 40mm. Where possible position laps so that water runs across or parallel to the laps. Checking the seams is a compulsory action at the end of any area of work. The welded seams have to cool down to ambient temperature before probing.

Regardless of the type of membrane attachment, mechanical fasteners are always required at the roofs perimeter, angle changes and any details. This ensures that any tensions generated in the field membrane are not transferred to other areas. In warm roofs, the insulation boards may also be mechanically attached. This should always be kept separate from the attachment of the waterproofing membrane.

Icopal recommends that Thermazone Insulation boards should be secured at a rate of 11 fasteners per 2400 x 1200mm (3.8 fixings/m<sup>2</sup>)

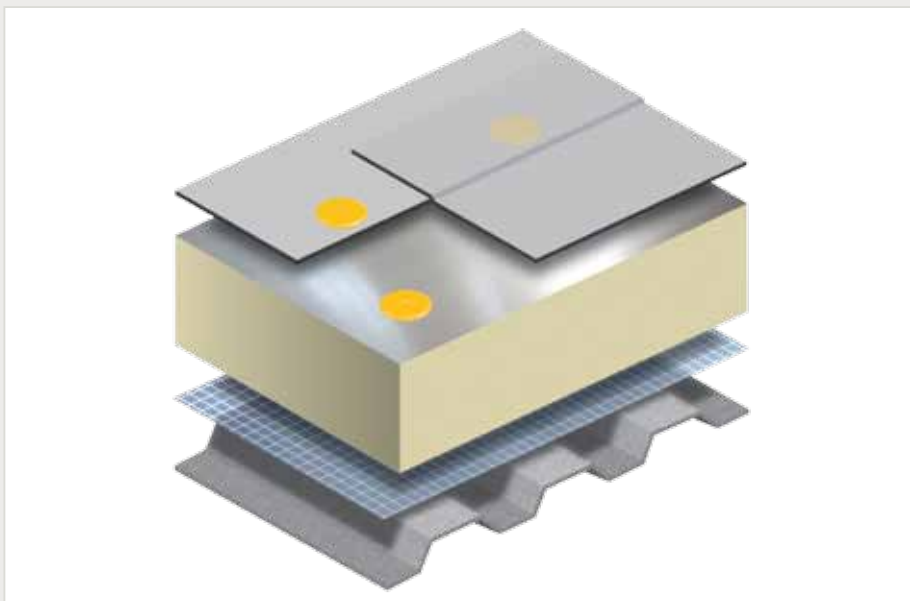

Monarplan FM PVC membrane is mechanically fastened independently of other elements.

# Monarplan FM

## Mechanically Fastened



### Side laps

When the sheets are fastened mechanically, a minimum 10mm free zone between the fasteners edge and the edge of the membrane must be observed. The minimum overlap should be approximately 140mm.

The overlap is calculated in following manner: 10mm free edge + width of washer (normally washers are 40mm wide, tubular washers are 50mm) + 60mm welding zone.

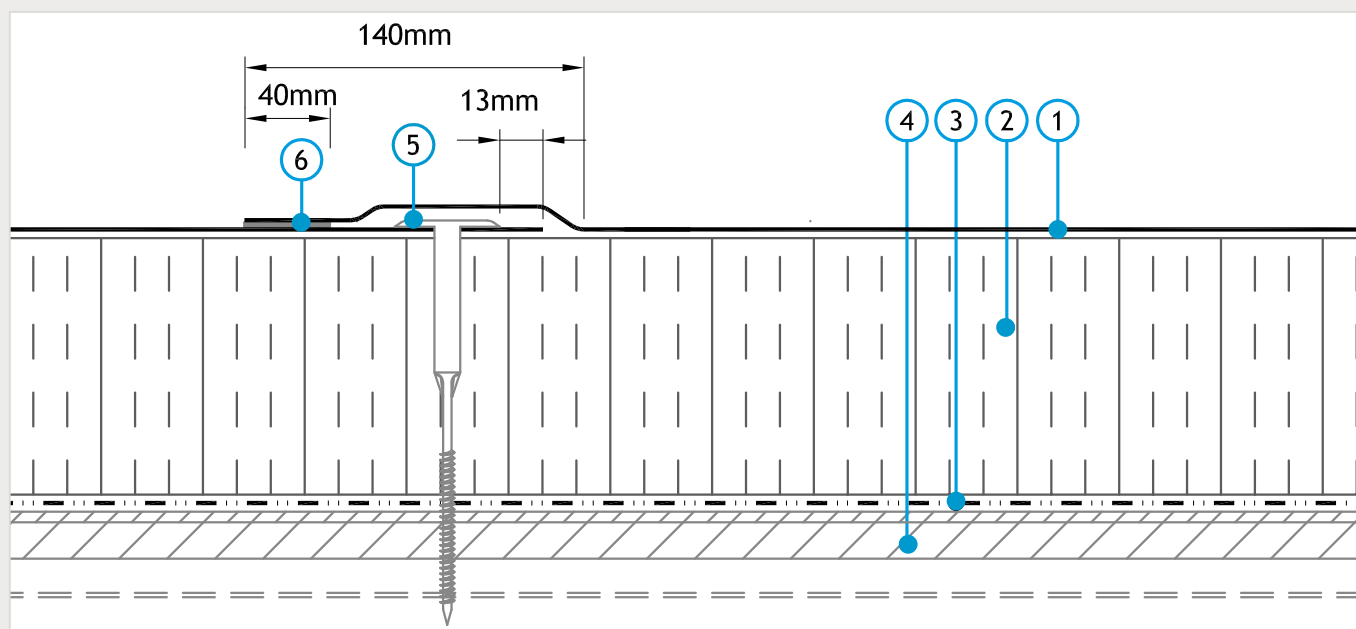

- 1 Monarplan FM single - ply membrane
- 2 Insulation
- 3 Vapour control layer
- 4 Substrate
- 5 Mechanical fixing
- 6 Hot air weld min. 40mm

# Monarplan FM Mechanically Fastened



## End laps

Position the overlapping sheet to ensure a minimum 40mm hot air weld is achieved.

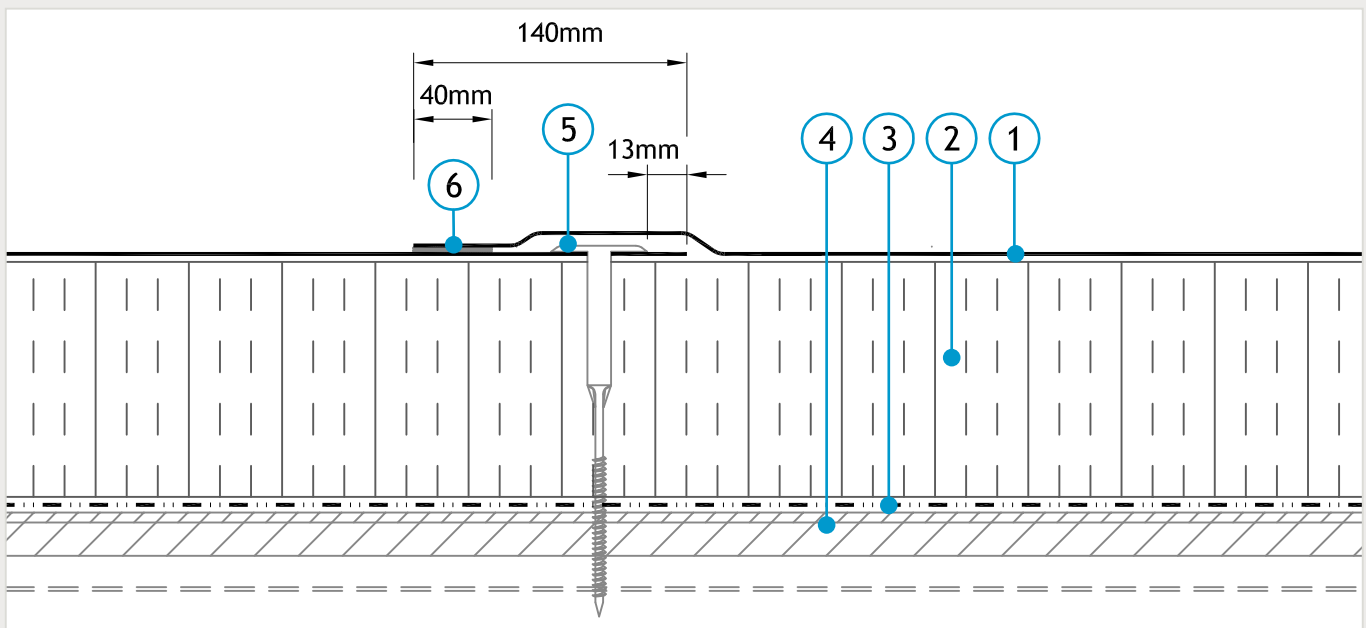

- 1 Monarplan FM single - ply membrane
- 2 Insulation
- 3 Vapour control layer
- 4 Substrate
- 5 Mechanical fixing
- 6 Hot air weld min. 40mm

## Monarplan fasteners & tube washers

Monarplan carbon coated steel fasteners should be used for Monarplan waterproofing systems requiring a guarantee of upto 15 years. For guaranteed Monarplan systems upto 20 years, Monarplan stainless steel fasteners should be used. Monarplan tubular washers should be used in conjunction with the fasteners. The yellow tube washer is for use with timber and metal decks. The white tube washer is for use with concrete decks.



# Monarplan FM Mechanically Fastened



## Mechanically fastened details

### Perimeter Upstand fixing

For all Monarplan PVC roof systems a perimeter fixing is compulsory. Mechanical fixings are also required around roof penetrations such as skylights, roof plant, lift houses, etc.

There are many different methods of achieving a perimeter upstand detail, each with differing levels of aesthetic finish. In each case the horizontal field membrane should be turned up the upstand a minimum 50mm. A minimum 150mm height above the finished roof level must be maintained when terminating to an abutment.

### Usual forms of perimeter fixings include:

- A. A 90° coated metal angle of sufficient width and height fixed back to the most robust surface (eg. vertically or horizontally to concrete or masonry) for both internal and external angles. Upstands with a height > 500mm, will require additional mechanical restraint.

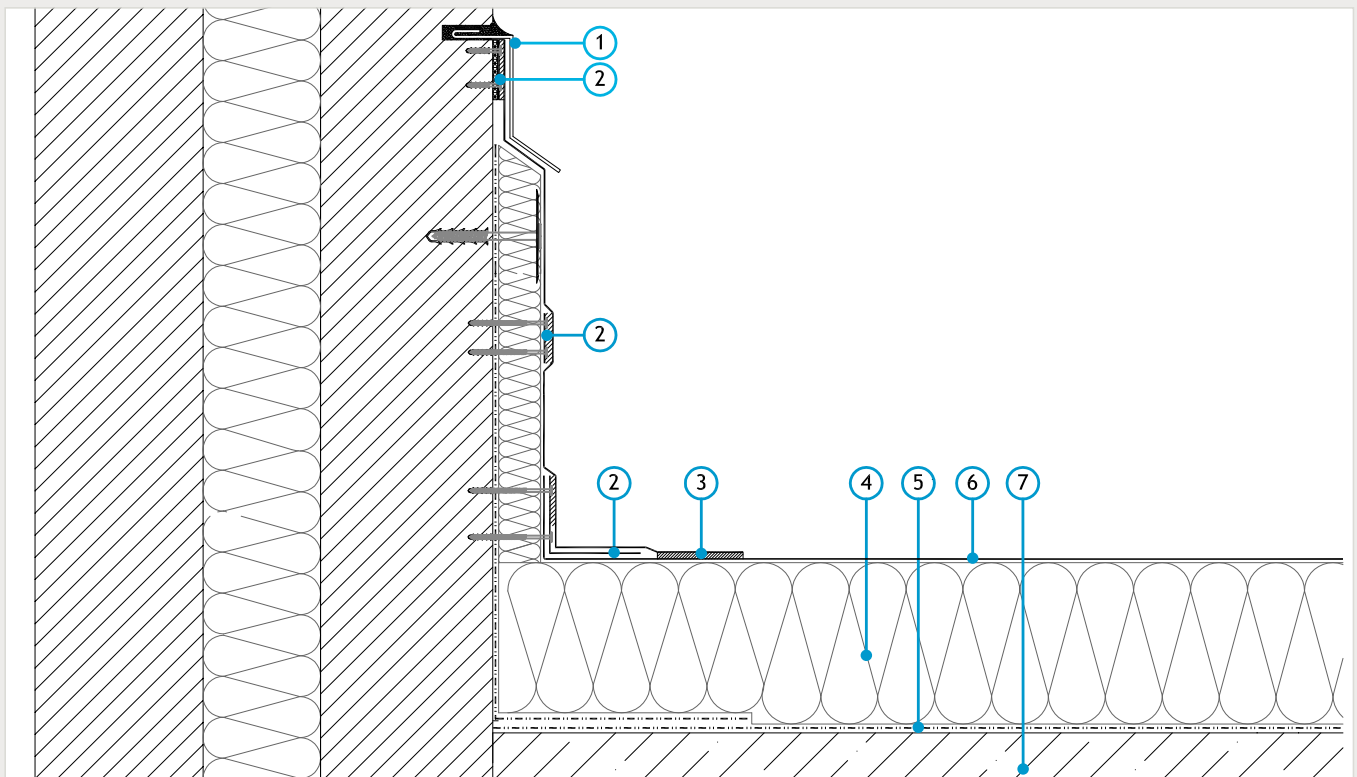

1 Cover flashing

2 Monarplan PVC coated metal & hot air weld

3 Hot air weld min. 40mm

4 Insulation

5 Vapour control layer

6 Monarplan FM reinforced membrane

7 Substrate

# Monarplan FM Mechanically Fastened



B. Membrane is fixed at the base of the upstand using a fixing bar or termination bar and is taken up and across the parapet / upstand detail and terminated on the outside edge. The upstand detail is completed with the installation of a metal capping by others.

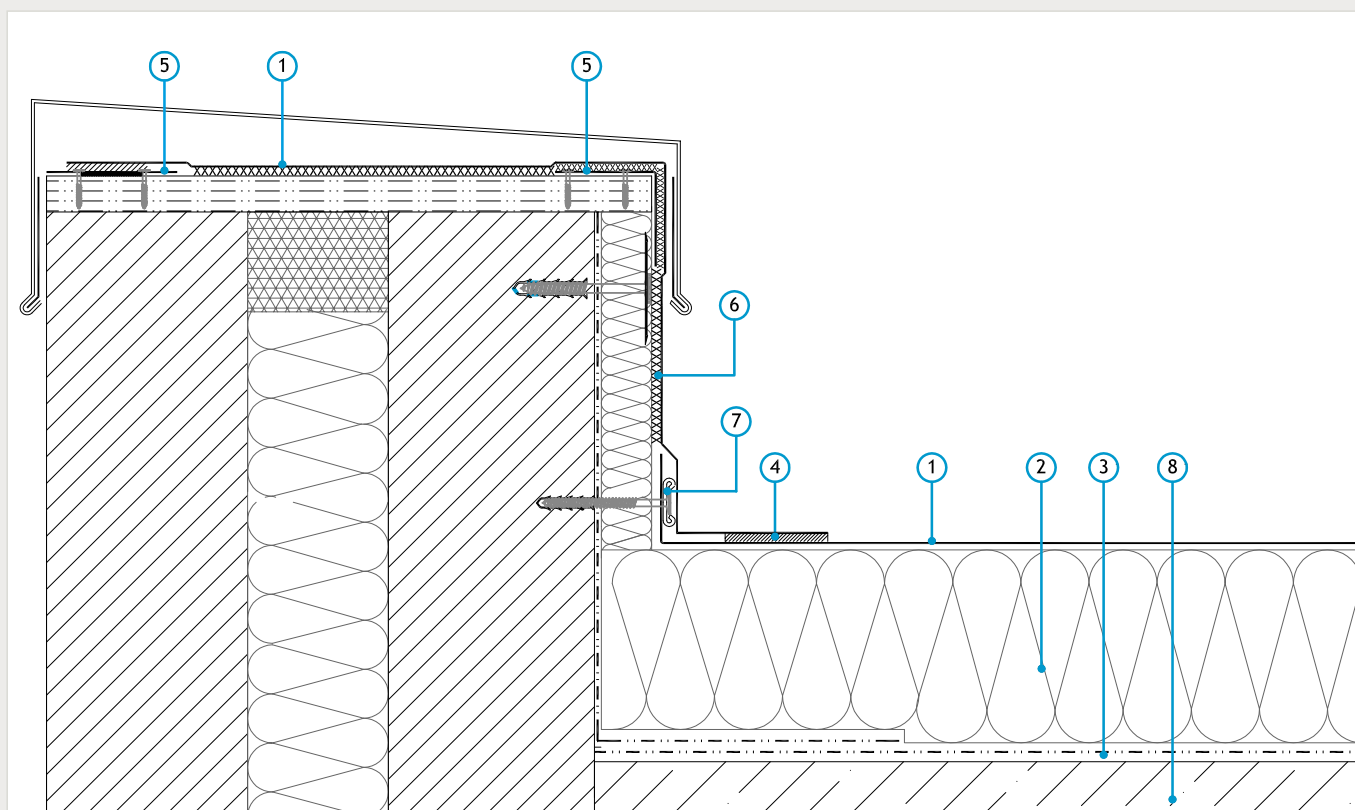

- 1 Monarplan FM reinforced membrane
- 2 Insulation
- 3 Vapour control layer
- 4 Hot air weld min. 40mm

- 5 Monarplan coated metal
- 6 Monarplan contact adhesive
- 7 Monarplan fixing bar
- 8 Substrate

# Monarplan FM

## Mechanically Fastened



C. As previous, however the bars are replaced with Monarplan tube washers and fasteners mechanically fixed at pre-determined centres.

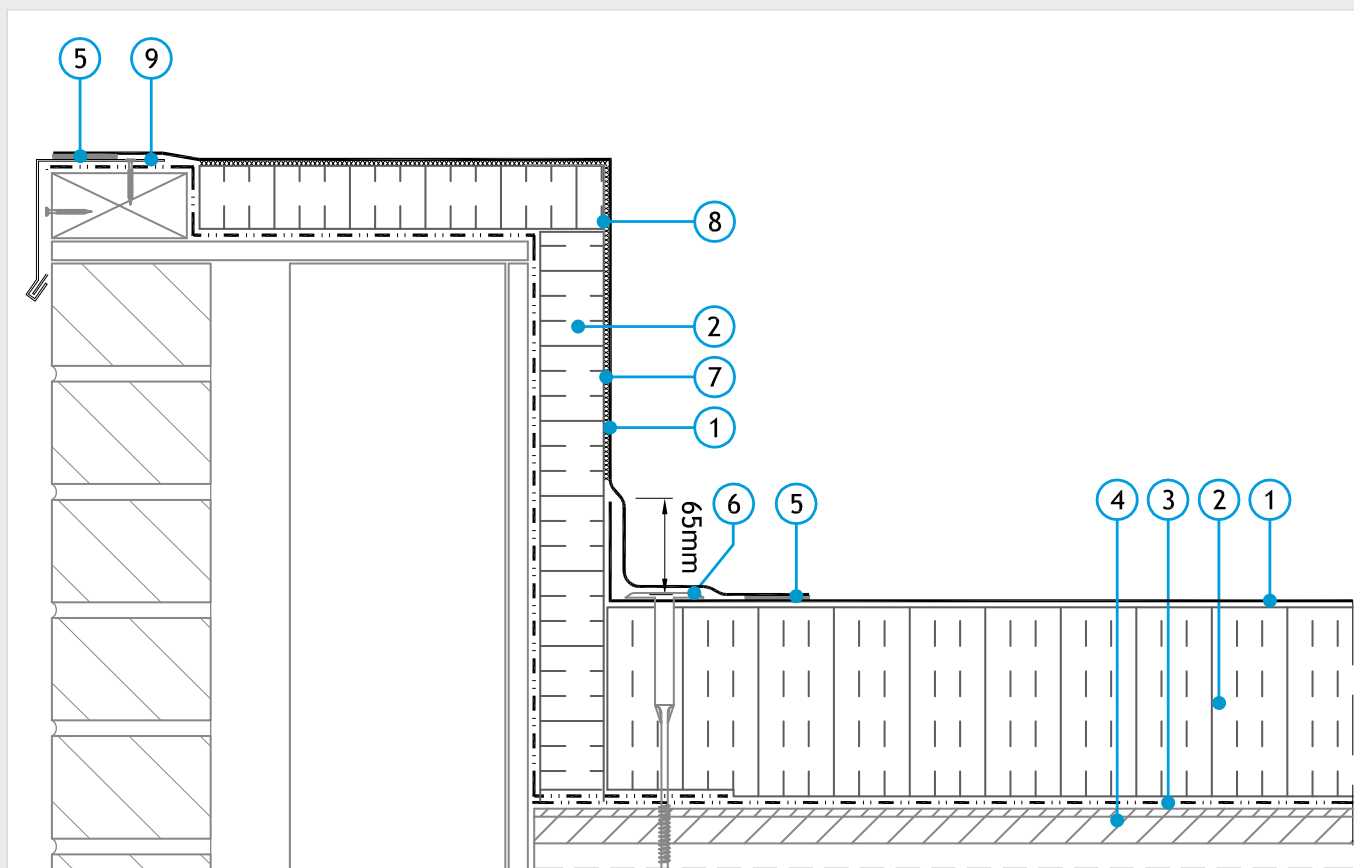

- 1 Monarplan FM single - ply membrane
- 2 Insulation
- 3 Vapour control layer
- 4 Substrate
- 5 Hot air weld min. 40mm

- 6 Mechanical fixing
- 7 Contact adhesive
- 8 Steel angle as hard edge
- 9 Coated metal

# Monarplan FM Mechanically Fastened



D. Installation of a horizontal perforated galvanized steel rail with 5 fixings / m fixed with the membrane tightly folded back and welded on itself – as close to the rail as possible.

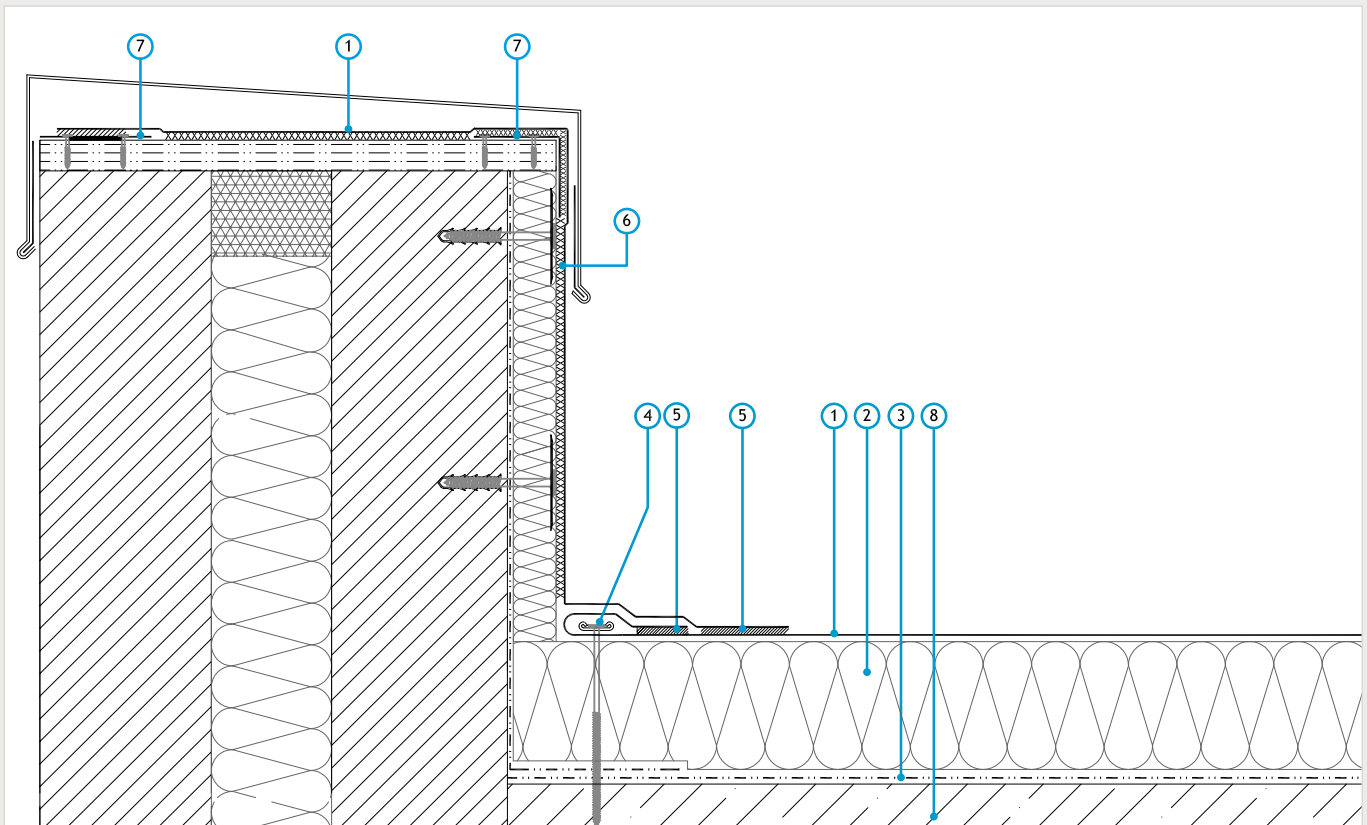

- 1 Monarplan FM reinforced membrane
- 2 Insulation
- 3 Vapour control layer
- 4 Monarplan fixing bar

- 5 Hot air weld min. 40mm
- 6 Monarplan contact adhesive
- 7 Monarplan coated metal
- 8 Substrate

# Monarplan FM

## Mechanically Fastened



### Tall upstands

For upstands with a height greater than 500mm an intermediate linear horizontal fixing is required, to be repeated every 500mm.

#### Possible detailing:

- Strip of PVC laminated steel fixed to the wall (see below),
- Perforated metal rail fixed through the membrane covered and sealed by a 100mm + width of Monarplan membrane strip,
- Lower flashing strip is fixed to wall by a perforated rail or screws and washers then the upper strip is overlapped and welded to the lower flashing,
- Fully adhered.

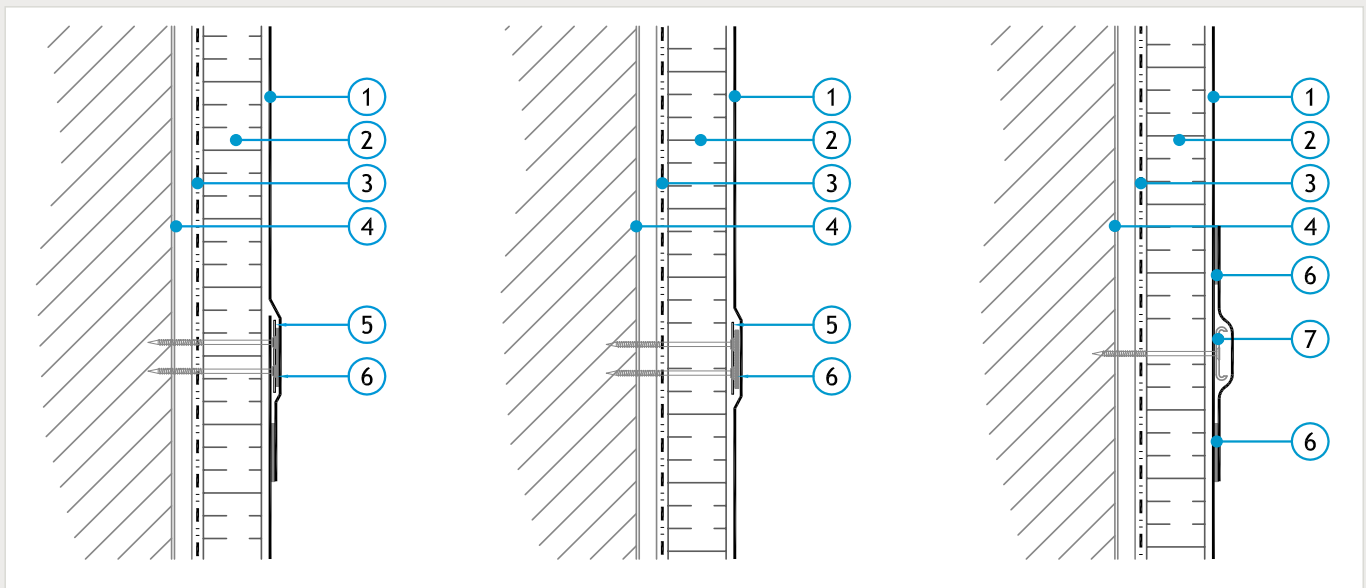

- 1 Monarplan FM single - ply membrane
- 2 Insulation
- 3 Vapour control layer
- 4 Substrate

- 5 Coated metal
- 6 Hot air weld min. 40mm
- 7 Mechanical fixing bar

There are many more alternative methods of detailing upstands.

Contact Icopal's Technical Services Department for detailed drawings or more information.

# Monarplan FM Mechanically Fastened



## Roof edge detail

Whenever possible, external roof finishes shall be constructed using Monarplan PVC coated metal. Separate lengths of the trim are butt jointed (leaving a 5mm gap for expansion) and strapped with Monarplan D.

Located beneath the vapour control layer (if applicable) and coated metal shall be Monobond LT tape to prevent the penetration of wind.

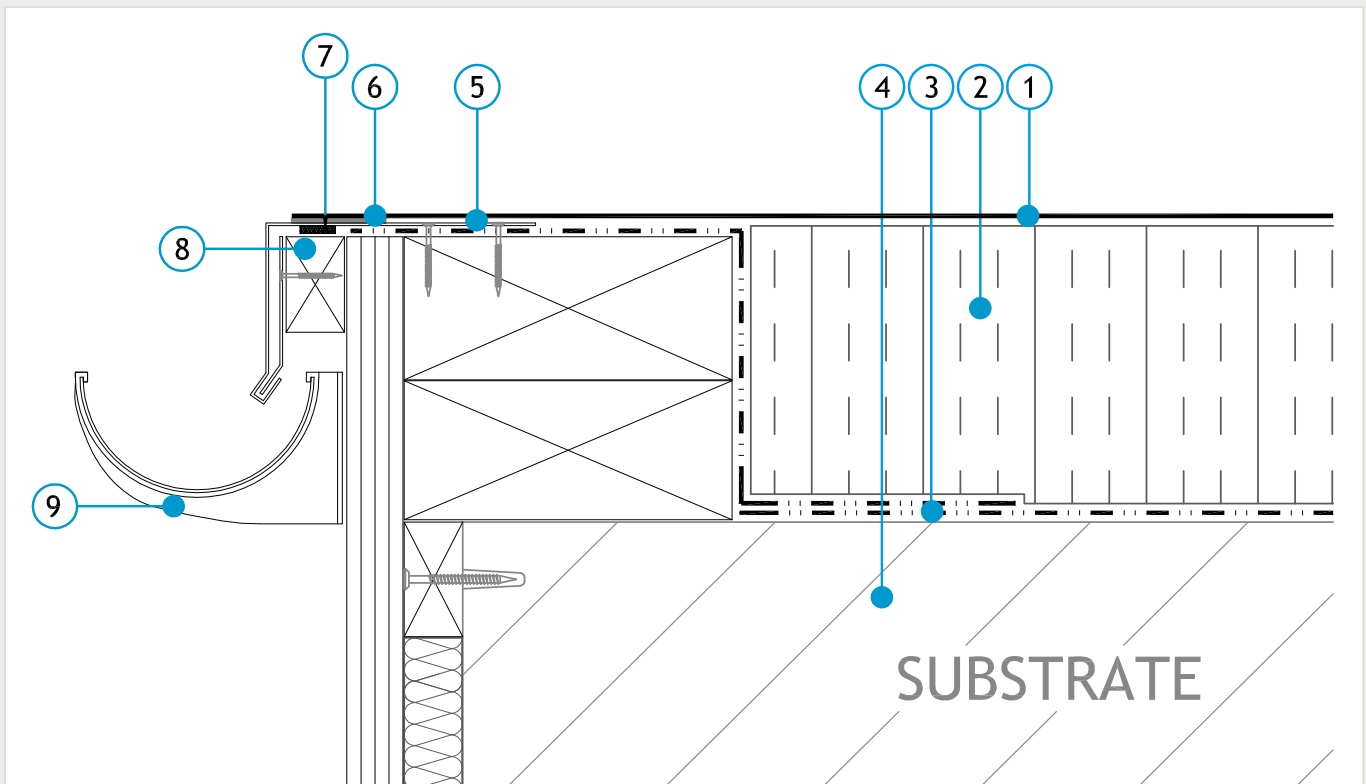

- 1 Monarplan FM single-ply membrane
- 2 Insulation
- 3 Vapour control layer
- 4 Substrate
- 5 Coated Metal

- 6 Hot air weld min.40mm
- 7 Sealing tape
- 8 Timber batten
- 9 Gutter

# Monarplan FM Mechanically Fastened



## Roof edge detail: coated metal edge - installation procedure

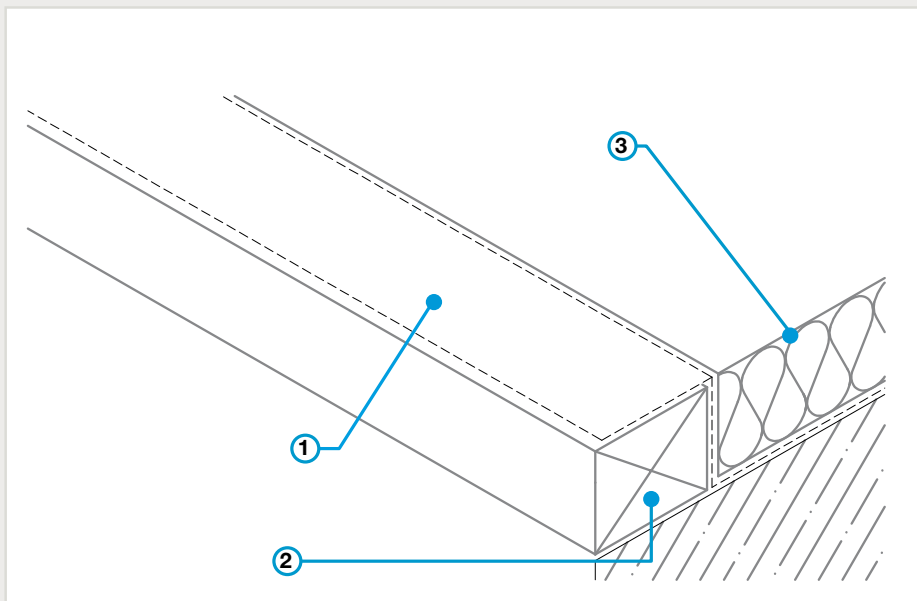

- 1 Vapour control layer
- 2 Treated timber edge batten to match insulation thickness
- 3 Insulation

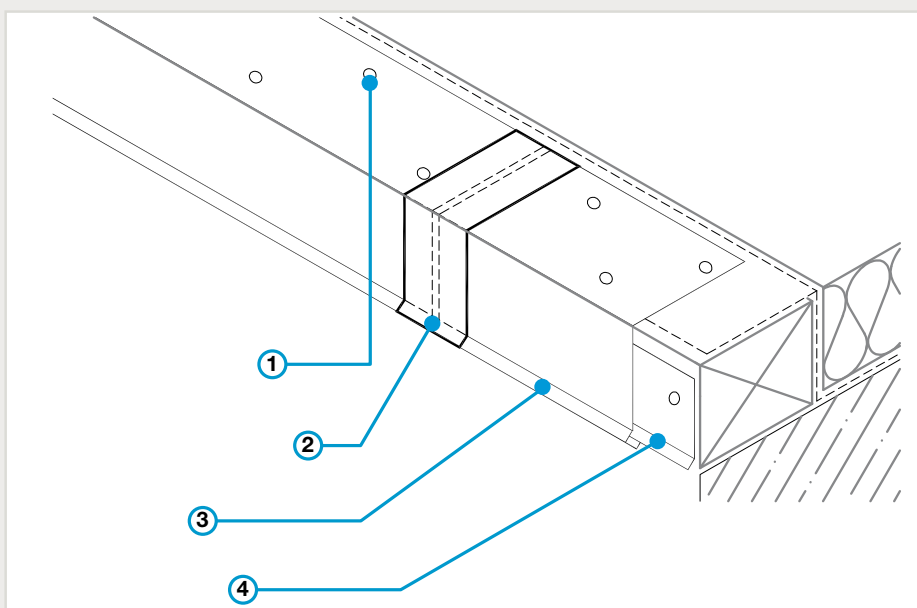

- 1 Screw fix at 150mm staggered centers, must penetrate the timber min. 25mm
- 2 50mm wide duct tape over 5mm butt joint
- 3 Monarplan coated metal
- 4 Min 0,6mm continuous cleat

# Monarplan FM Mechanically Fastened



## Roof edge detail: coated metal edge - installation procedure

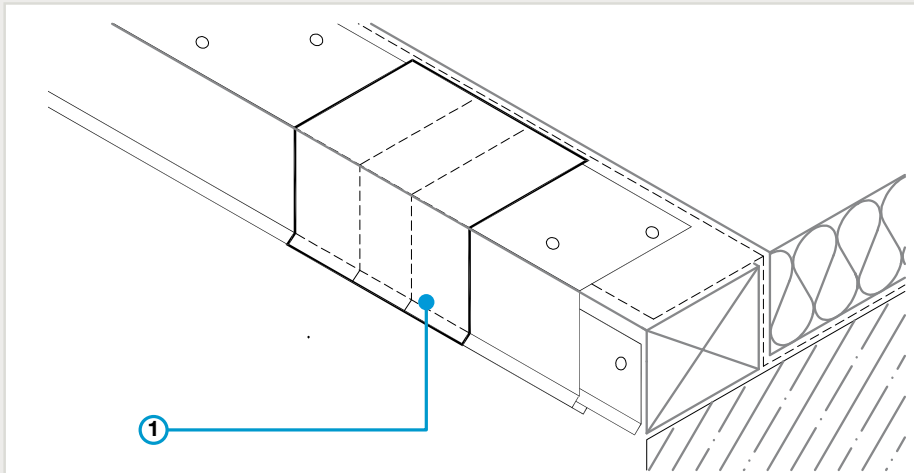

- 1 Heat weld 150mm wide piece of Monarplan D non-reinforced membrane over joint

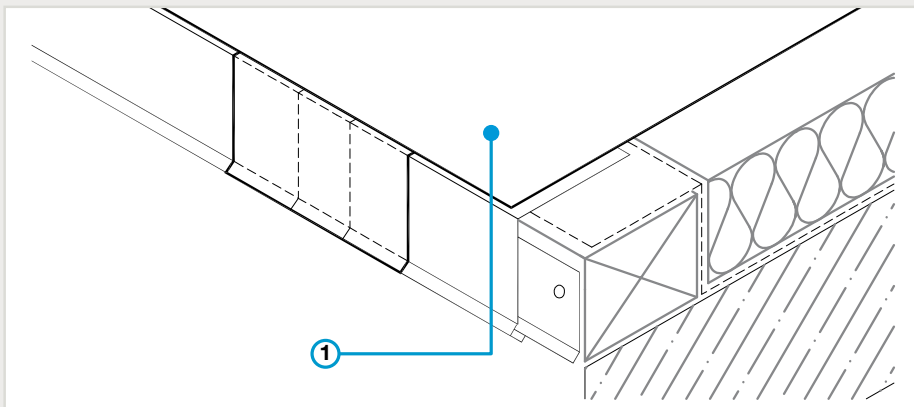

- 1 Monarplan FM reinforced membrane

# Monarplan GF Fleeceback Fully Adhered



## Installation advice

Monarplan GF fleeceback membrane is glass fibre reinforced PVC with a polyester fleece backing. The fleece backing allows the membrane to be fully adhered using cold applied adhesives to restrain the membrane to the insulation.

Monarplan GF fleeceback membrane is fully bonded to Thermazone Roofboard insulation using Monarplan fleeceback adhesive. The adhesive should be poured onto the insulation board and manipulated using a rubber squeegee and perlon roller to achieve uniform distribution (avoid puddles). Immediately apply the Monarplan GF membrane into the adhesive, being careful to correctly position the membrane. Roll the membrane using a weighted roller to encourage adhesion. Repeat the rolling process at 15 minute intervals until 45 minutes have elapsed to ensure a complete bond has been achieved.

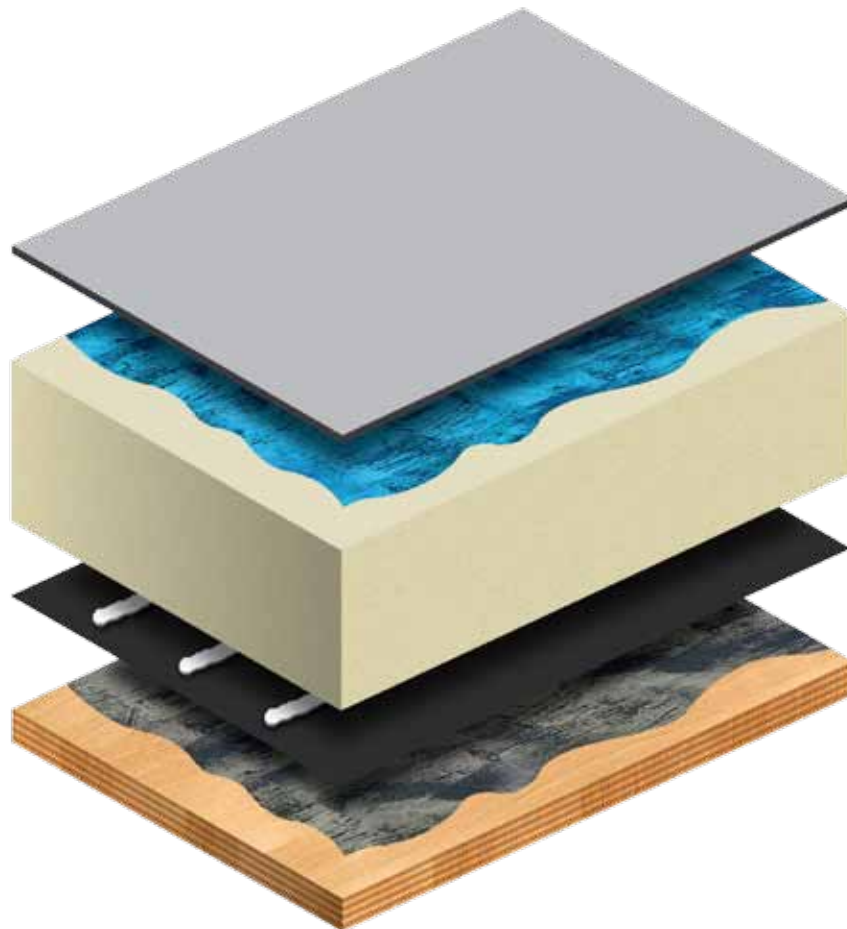

# Monarplan GF Fleeceback Fully Adhered



## Side laps

Monarplan GF fleeceback membranes are manufactured with a 75mm fleece free selvage. Position the adjoining sheet allowing for a 50mm side lap (using the pre-printed overlap line) and close butt end lap, bond in place as above. Weld the side lap, using techniques outlined below.

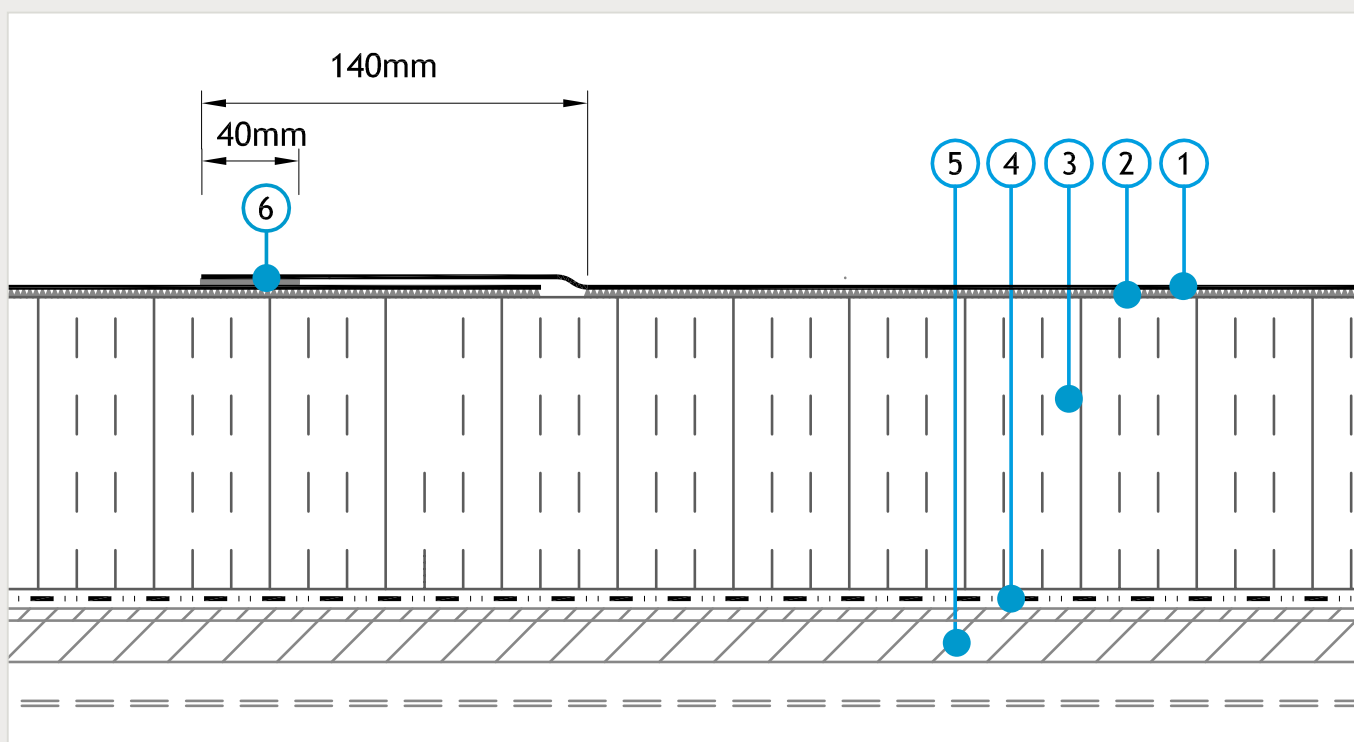

- 1 Monarplan GF fleeceback membrane
- 2 Fleeceback adhesive
- 3 Insulation
- 4 Vapour control layer
- 5 Substrate
- 6 Hot air weld min. 40mm

# Monarplan GF Fleeceback Fully Adhered



## End laps

Overlay the end lap (butt joint) or where there is no selvage edge, with a 150mm strip of reinforced Monarplan membrane centred over the joint and fully welded in position.

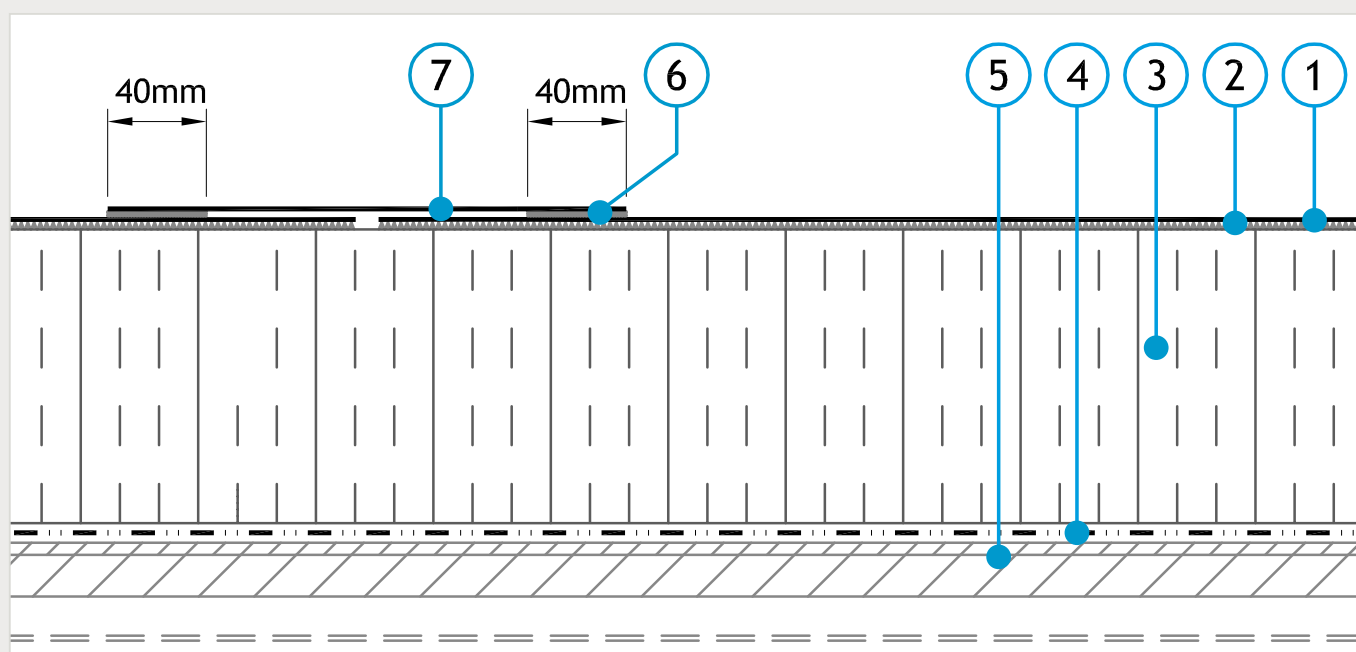

- 1 Monarplan GF fleeceback membrane
- 2 Fleeceback adhesive
- 3 Insulation
- 4 Vapour control layer
- 5 Substrate
- 6 Hot air weld min. 40mm
- 7 Monarplan Reinforced strip

# Monarplan GF Fleeceback Fully Adhered



## Fully adhered details

### Perimeter upstand fixing

For all Monarplan PVC roof systems a perimeter fixing is compulsory. Mechanical fixings are also required around roof penetrations such as skylights, roof plant, lift houses, etc

There are many different methods of achieving a perimeter upstand detail, each with differing levels of aesthetic finish. In each case the horizontal field membrane should be turned up the upstand a minimum 50mm. A minimum 150mm height above the finished roof level must be maintained, when terminating to an abutment.

### Usual forms of perimeter fixings include:

A. A 90° coated metal angle of sufficient width and height fixed back to the most robust surface (eg. vertically or horizontally to concrete or masonry) for both internal and external angles. Upstands with a height > 500mm, will require additional mechanical restraint.

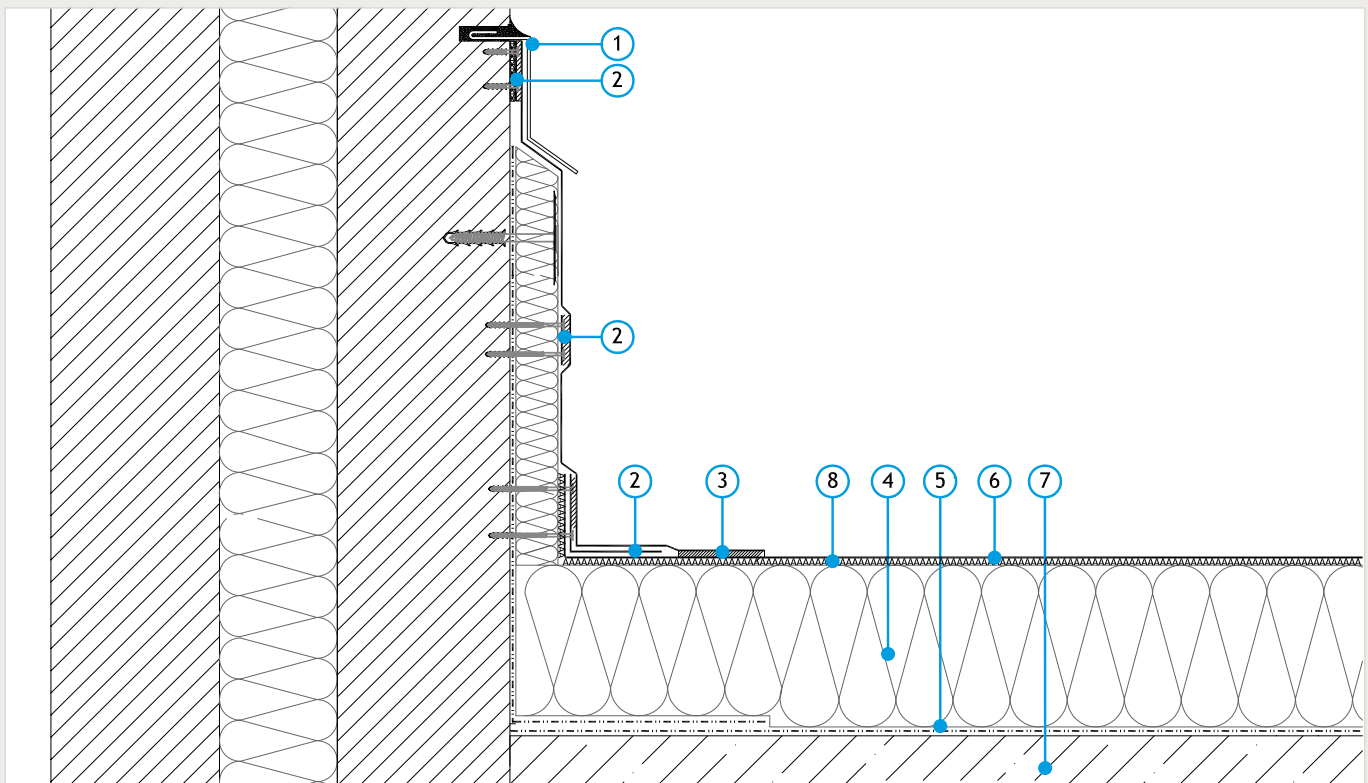

1 Cover flashing

2 Monarplan PVC coated metal & hot air weld

3 Hot air weld min. 40mm

4 Insulation

5 Vapour control layer

6 Monarplan GF fleeceback membrane

7 Substrate

8 Monarplan fleeceback adhesive

# Monarplan GF Fleeceback Fully Adhered



B. Membrane is fixed at the base of the upstand using a fixing bar or termination bar and is taken up and across the parapet / upstand detail and terminated on the outside edge. The upstand detail is completed with the installation of a metal capping by others.

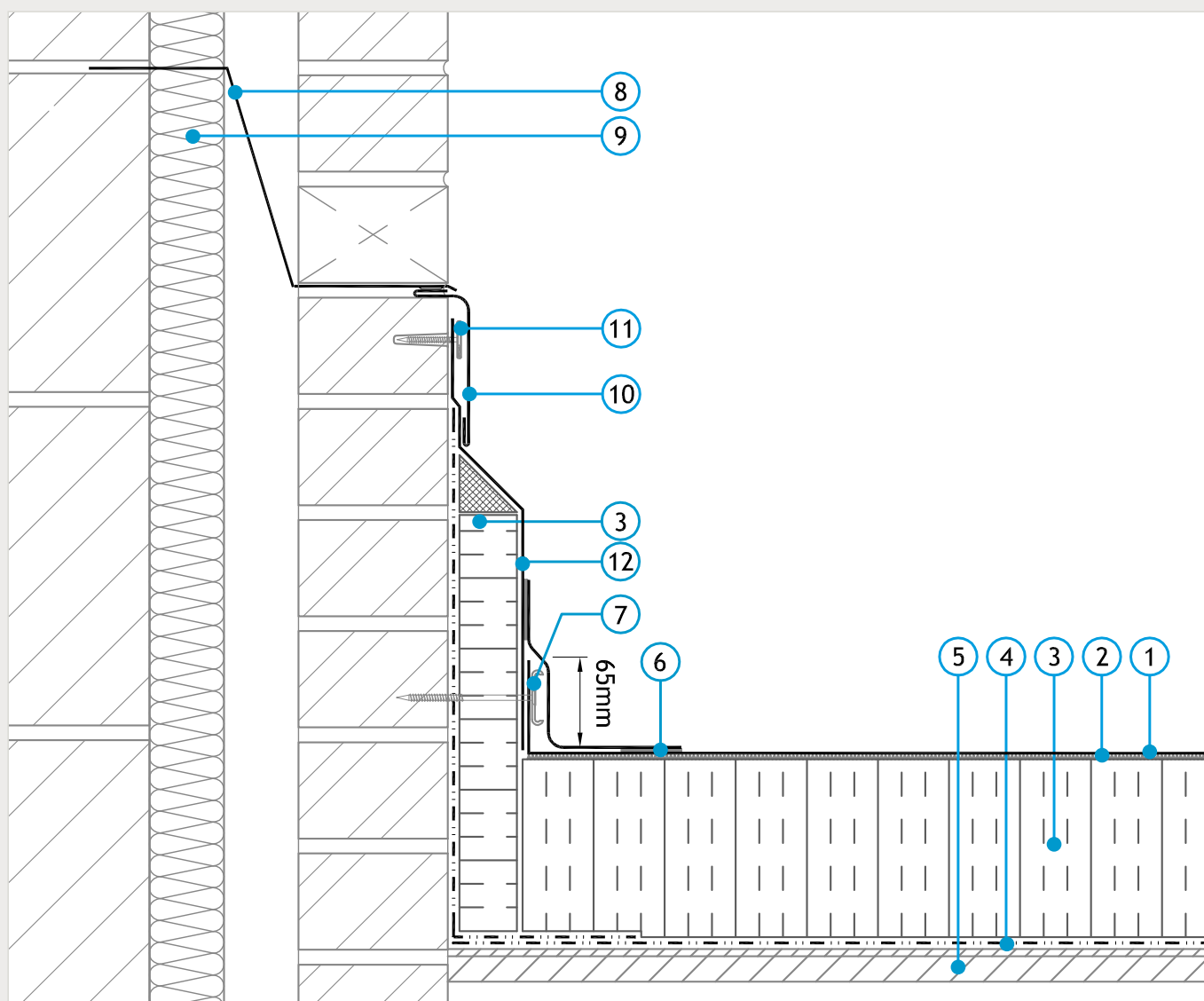

- 1 Monarplan GF fleeceback membrane
- 2 Fleeceback adhesive
- 3 Insulation
- 4 Vapour control layer

- 5 Substrate
- 6 Hot air weld min.40mm
- 7 Mechanical fixing bar
- 8 DPC

- 9 Insulation
- 10 Cover flashing
- 11 Mechanical termination
- 12 Monarplan FM single - ply membrane

# Monarplan GF Fleeceback Fully Adhered



C. As above, however the bars are replaced with Monarplan tube washers and fasteners mechanically fixed at pre-determined centres.

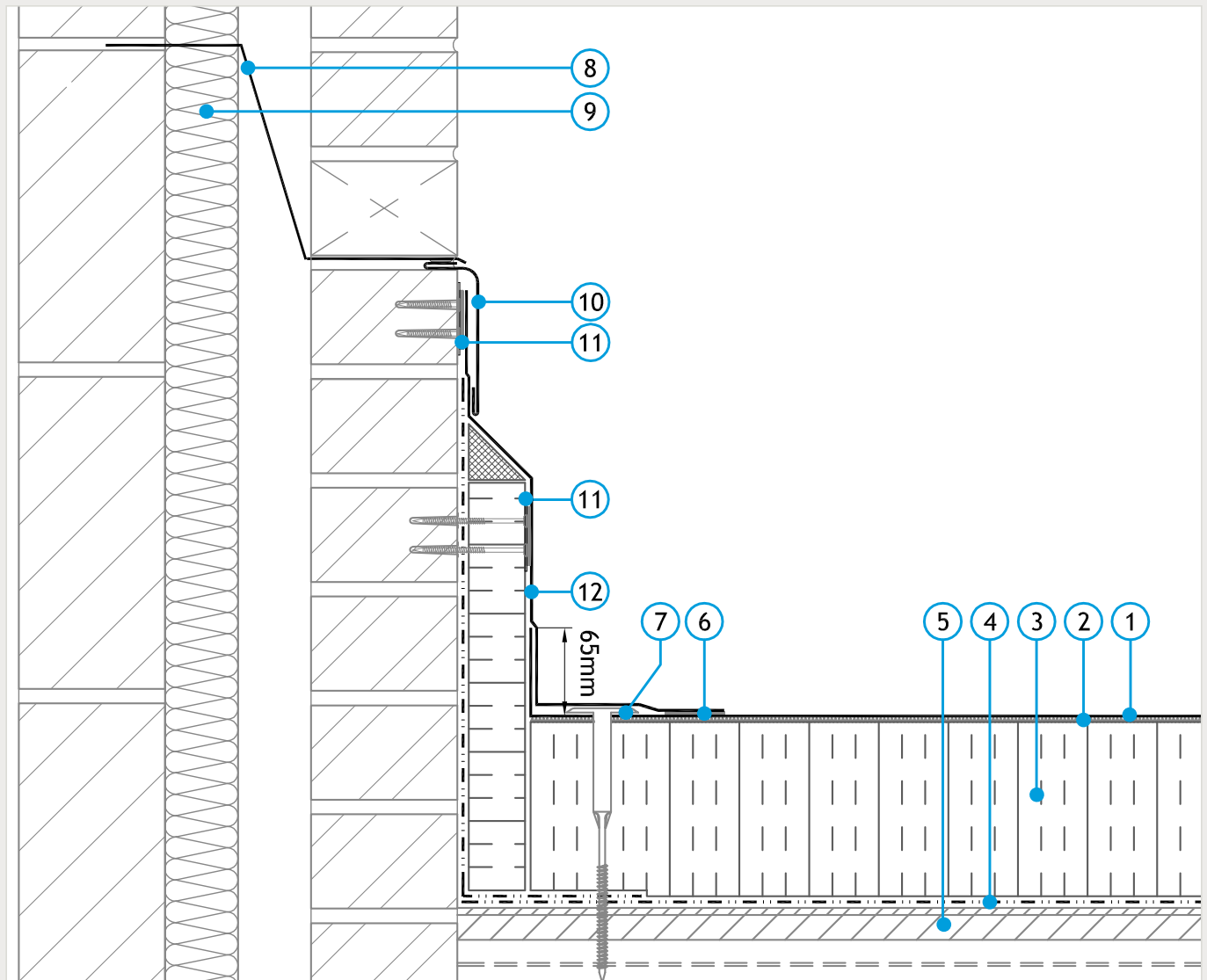

- 1 Monarplan GF fleeceback membrane
- 2 Fleeceback adhesive
- 3 Insulation
- 4 Vapour control layer

- 5 Substrate
- 6 Hot air weld .40mm
- 7 Mechanical fixing
- 8 DPC

- 9 Insulation
- 10 Cover flashing
- 11 Coated metal
- 12 Monarplan FM single-ply membrane

# Monarplan GF Fleeceback Fully Adhered



D. Installation of a horizontal perforated galvanized steel rail with 5 fixings / m fixed with the membrane tightly folded back and welded on itself – as close to the rail as possible.

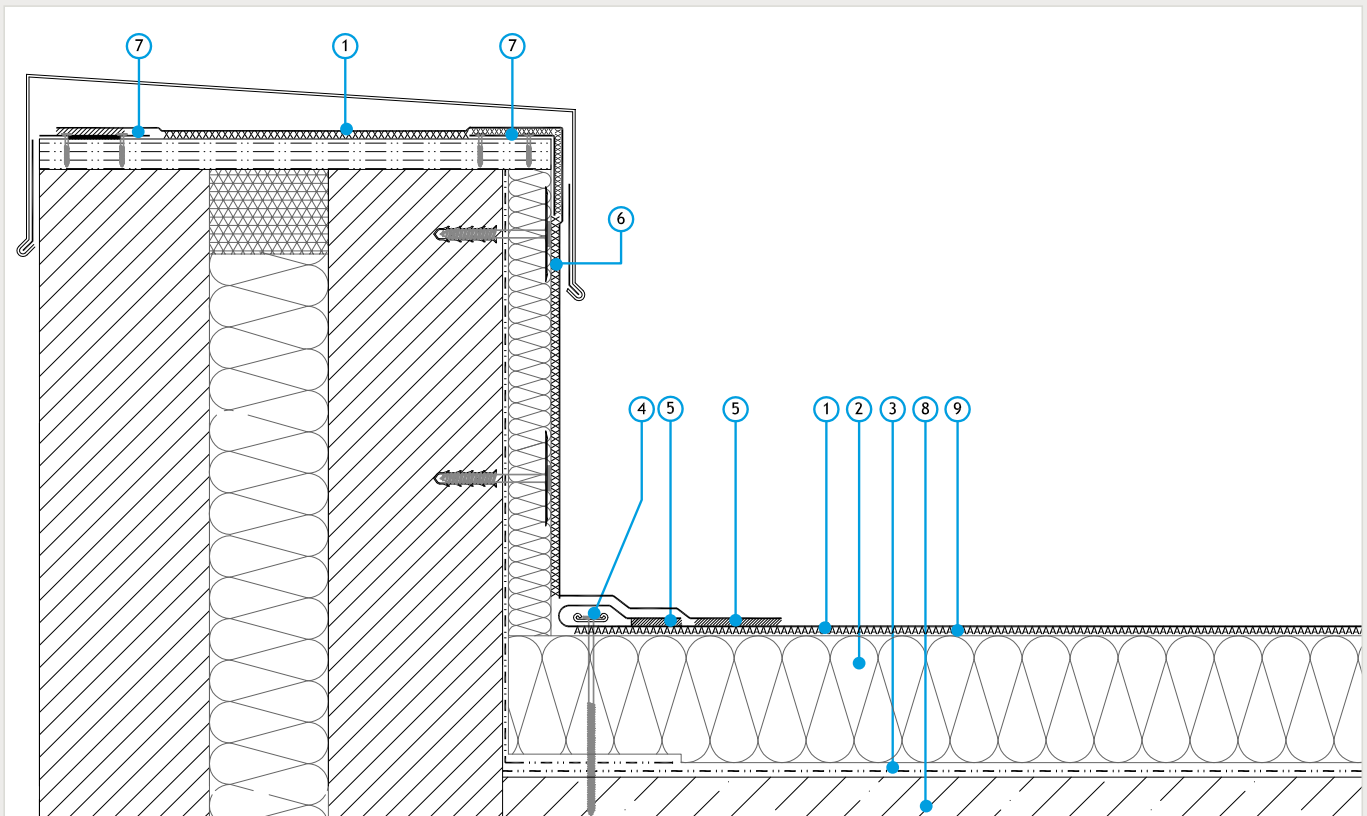

1 Monarplan GF Fleeceback membrane

2 Insulation

3 Vapour control layer

4 Monarplan fixing bar

5 Hot air weld min. 40mm

6 Monarplan contact adhesive

7 Monarplan coated metal

8 Substrate

9 Monarplan fleeceback adhesive

# Monarplan GF Fleeceback Fully Adhered



## Tall upstands

For upstands with a height greater than 500mm an intermediate linear horizontal fixing is required, to be repeated every 500mm.

### Possible detailing:

- Strip of PVC laminated steel fixed to the wall (see below).
- Perforated metal rail fixed through the membrane covered and sealed by a 100mm + width of Monarplan membrane strip.
- Lower flashing strip is fixed to wall by a perforated rail or screws and washers then the upper strip is overlapped and welded to the lower flashing.
- Fully adhered.

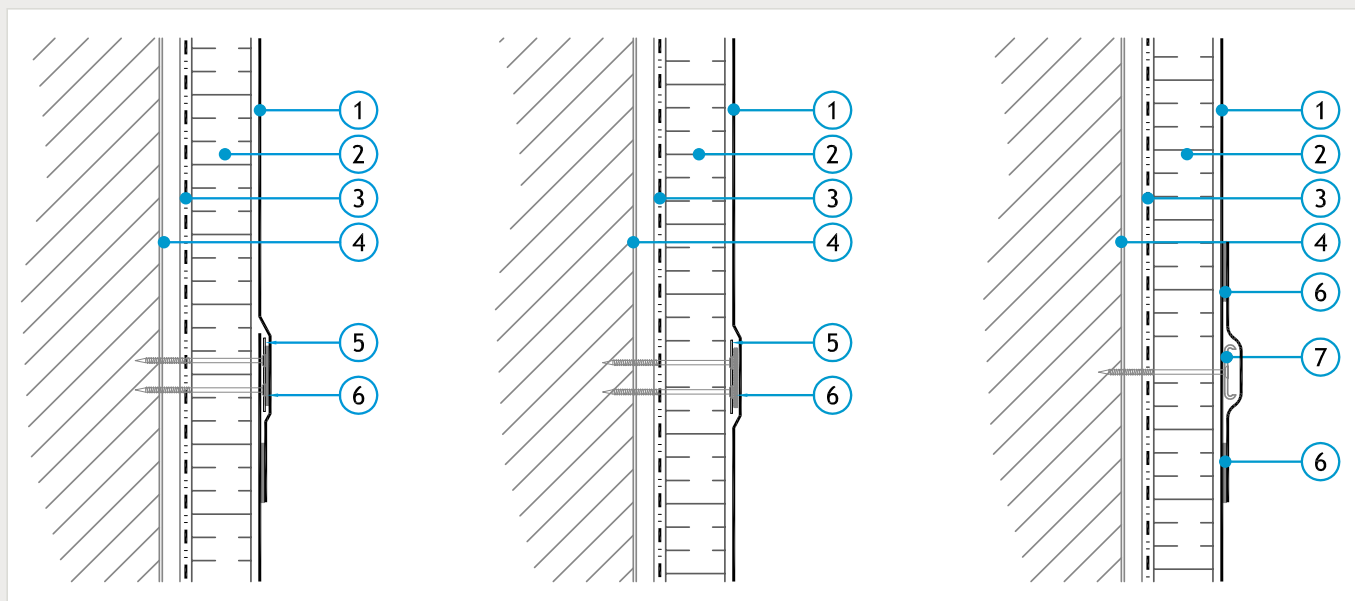

- 1 Monarplan FM single-ply membrane
- 2 Insulation
- 3 Vapour control layer
- 4 Substrate

- 5 Coated metal
- 6 Hot air weld min. 40mm
- 7 Mechanical fixing bar

# Monarplan GF Fleeceback Fully Adhered



## Roof edge detail

Whenever possible, external roof finishes shall be constructed using Monarplan PVC coated metal. Separate lengths of the trim are butt jointed (leaving a 5mm gap for expansion) and strapped with Monarplan D.

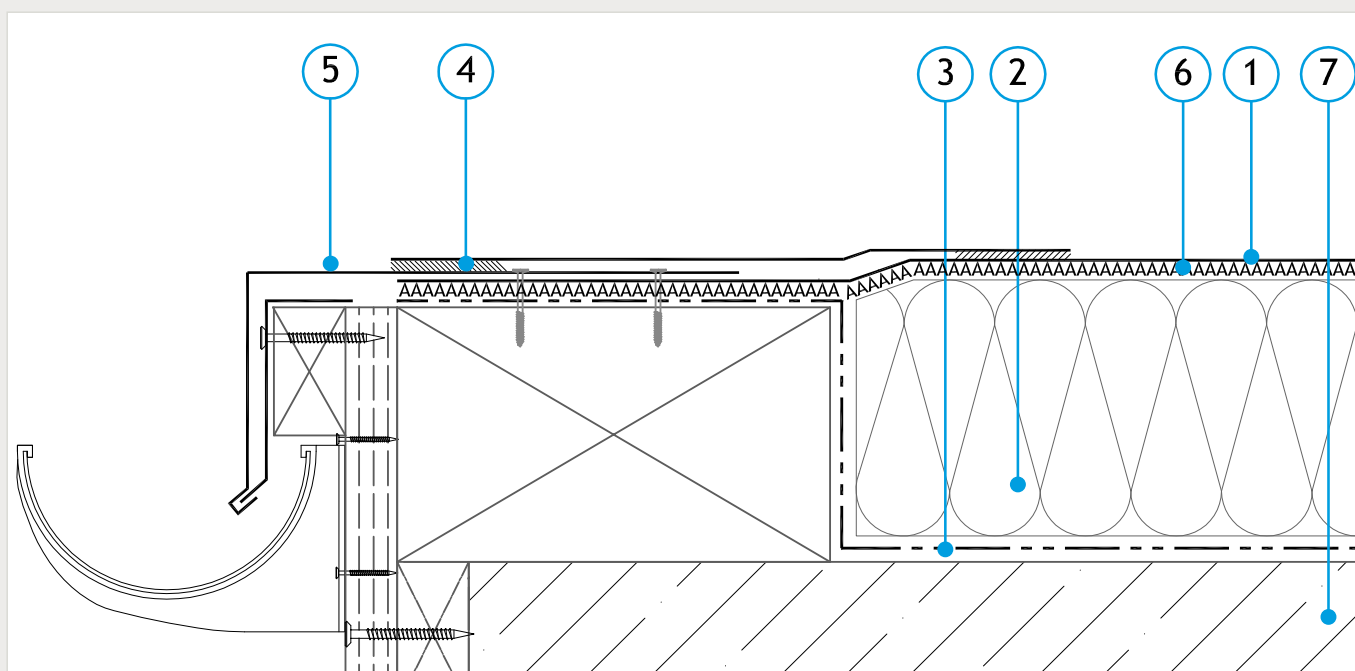

- |                                    |                                 |
|------------------------------------|---------------------------------|
| 1 Monarplan GF fleeceback membrane | 5 Monarplan coated metal        |
| 2 Insulation                       | 6 Monarplan fleeceback adhesive |
| 3 Vapour control layer             | 7 Substrate                     |
| 4 Hot air weld min. 40mm           |                                 |

# Monarplan GF Fleeceback Fully Adhered



## Roof edge detail: coated metal edge - installation procedure

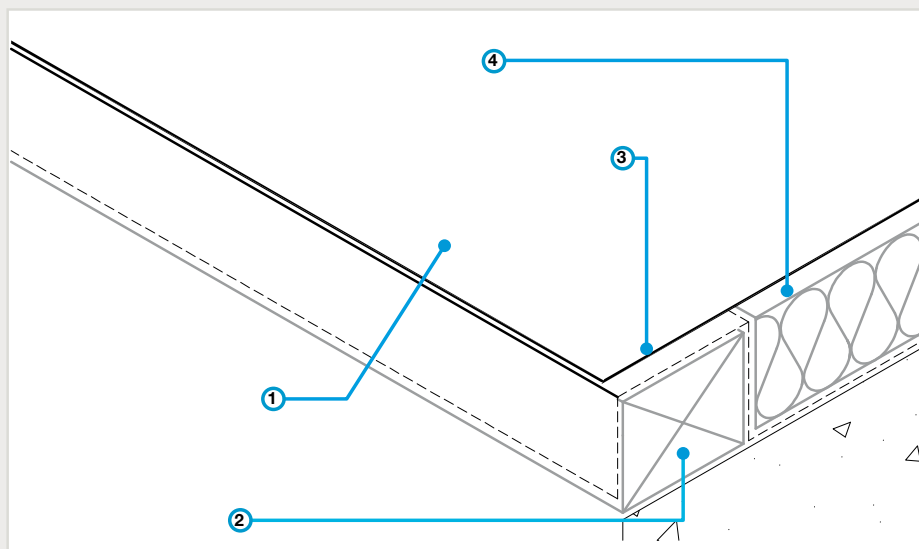

- 1 Monarplan PVC membrane
- 2 Treated timber edge batten to match insulation thickness
- 3 Vapour control layer as specified
- 4 Thermazone insulation as specified

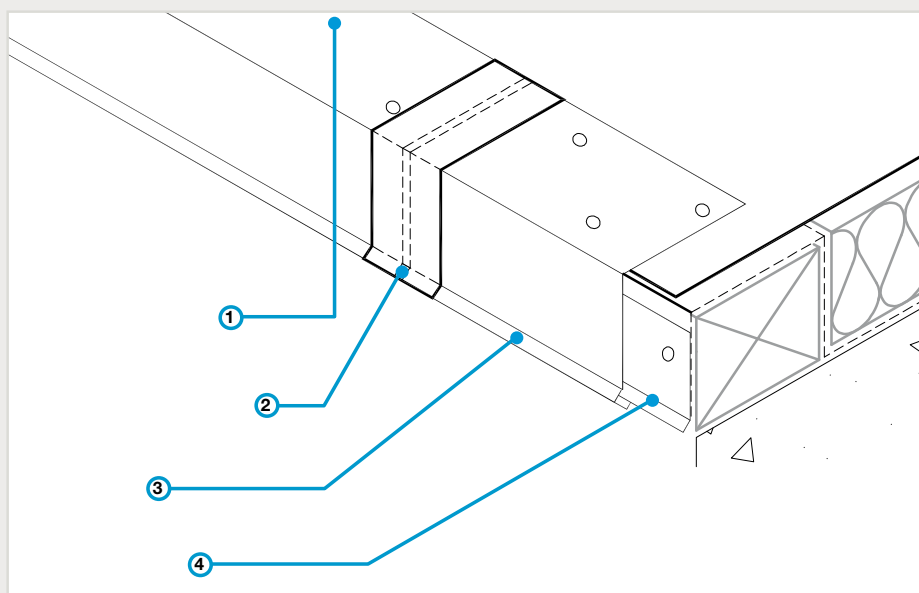

- 1 Screw fix at 150mm staggered centers, must penetrate the timber min. 25mm
- 2 50mm wide aluminium tape over 5mm joint
- 3 Monarplan PVC coated Metal
- 4 Min 0,6mm continuous cleat

# Monarplan GF Fleeceback Fully Adhered



## Roof edge detail: coated metal edge - installation procedure

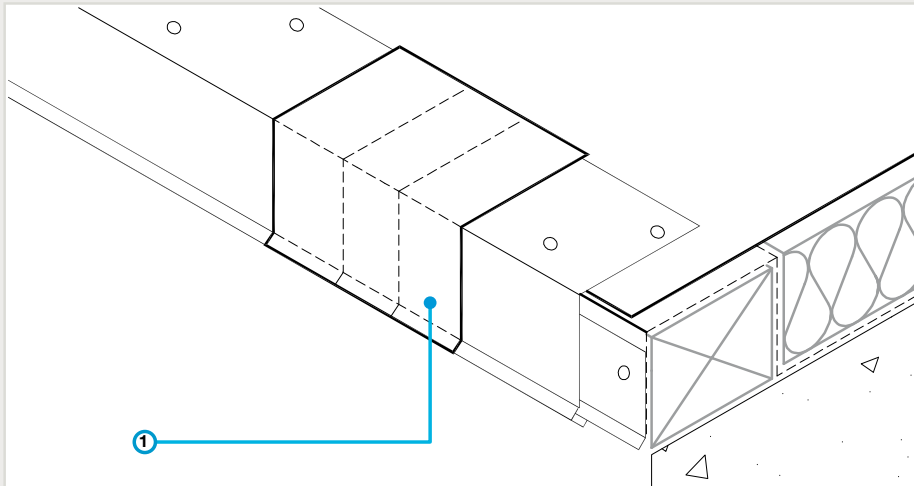

- 1 Heat weld 150mm wide piece of Monarplan PVC non-reinforced membrane over joint

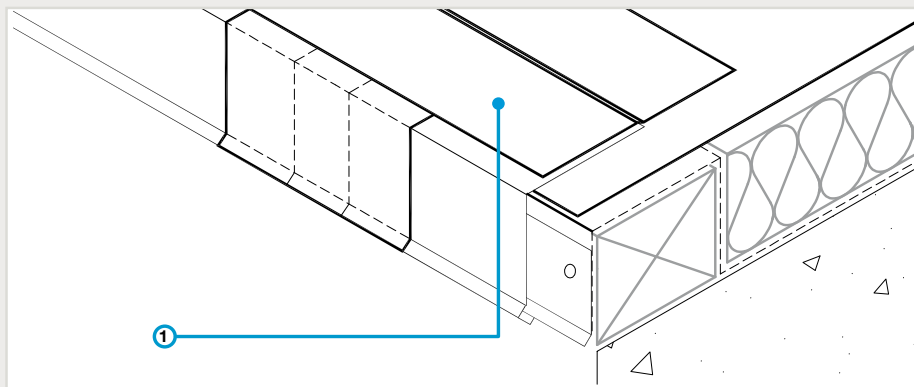

- 1 Monarplan PVC reinforced membrane cover strap

# Monarplan G Loose Laid & Ballasted



Ballasted systems rely on the weight of pebbles, paving slabs, green roofs or other medium to restrain the loosely laid Monarplan membrane. Ballast is commonly used for inverted roof build ups, however a warm roof option is also possible.

Loose lay Monarplan G glass fibre reinforced membrane prior to the application of the specified surfacing (eg. ballast or green roof). All overlaps shall be heat welded in accordance with the instructions below.

Protection layers are required for the mechanical protection of the roofing sheet prior to the application of roof ballast or green roofs.



# Monarplan G Loose Laid & Ballasted



## Loose laid & ballasted details

### Perimeter upstand fixing

For all Monarplan PVC roof systems a perimeter fixing is compulsory. Mechanical fixings are also required around roof penetrations such as skylights, strips, roof plant, lift houses, etc.

There are many different methods of achieving a perimeter upstand detail, each with differing levels of aesthetic finish. In each case the horizontal field membrane should be turned up the upstand a minimum 50mm. A minimum 150mm height above the finished roof level must be maintained, when terminating to an abutment.

### Usual forms of perimeter fixings include:

A. Membrane is fixed at the base of the upstand using a fixing bar or termination bar and is taken up and across the parapet / upstand detail and terminated on the outside edge. The upstand detail is completed with the installation of a metal capping by others.

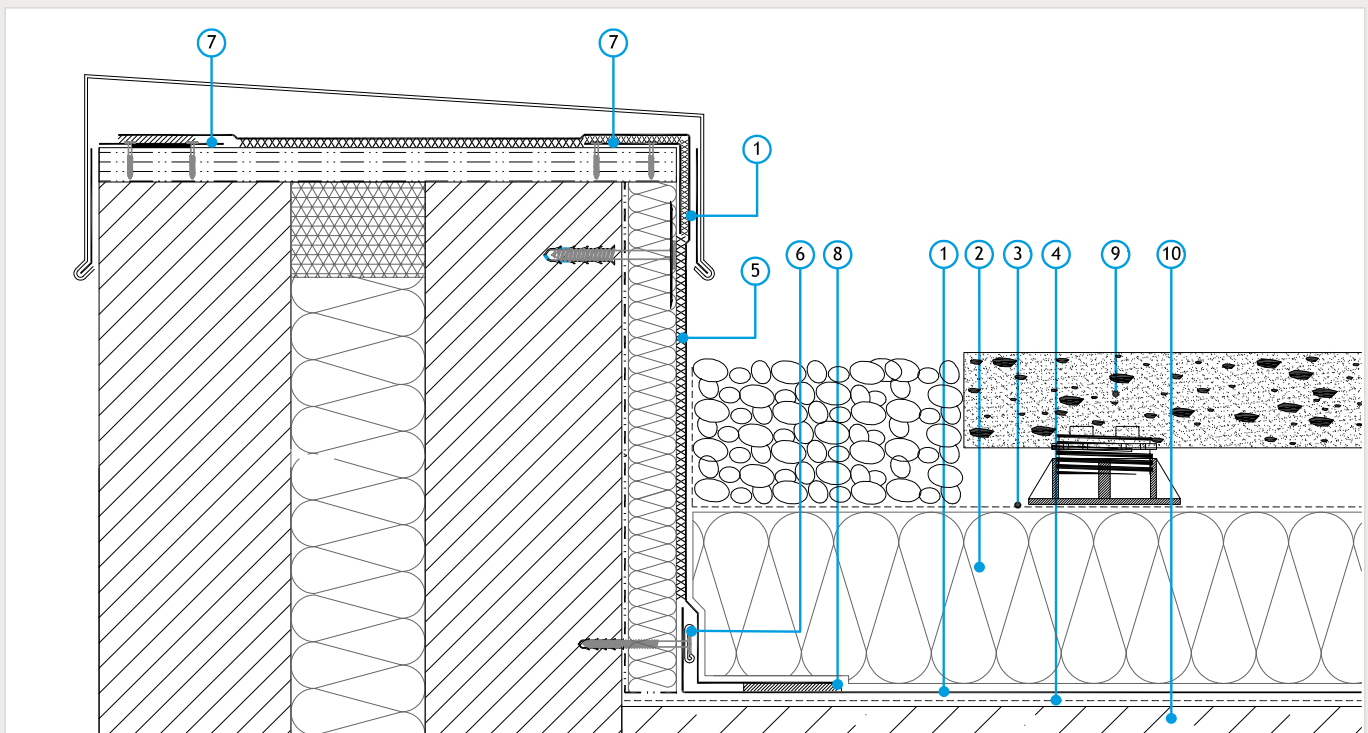

1 Monarplan G PVC membrane

2 Insulation

3 Filter fleece / breather membrane

4 Separation fleece

5 Monarplan contact adhesive

6 Monarplan fixing bar

7 Monarplan coated metal

8 Hot air weld min. 40mm

9 Ballast / paving slabs

10 Substrate

Polystyrene based insulation boards laid above the Monarplan PVC membrane must be separated with an appropriate separation fleece.

# Monarplan G Loose Laid & Ballasted



B. As above, however the bars are replaced with Monarplan tube washers and fasteners mechanically fixed at pre-determined centres.

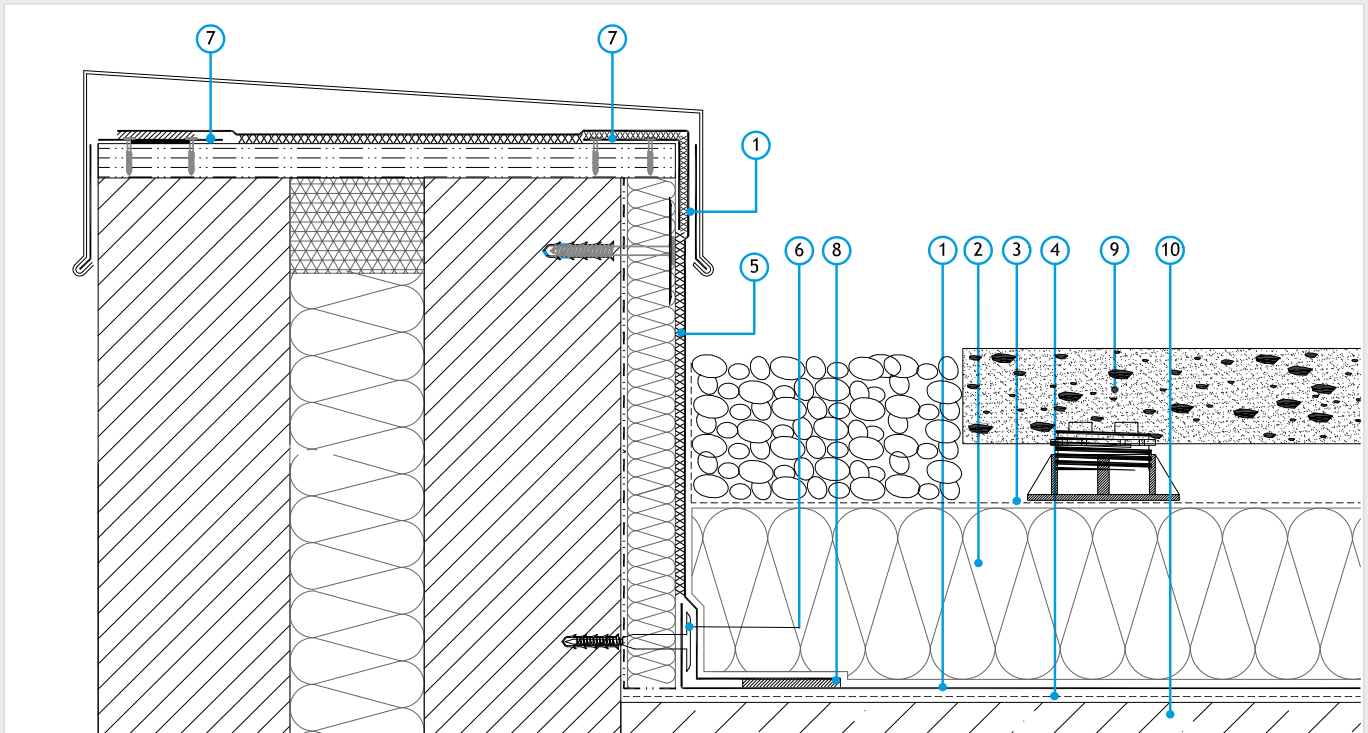

- 1 Monarplan G PVC membrane
- 2 Insulation
- 3 Filter fleece / breather membrane
- 4 Separation fleece

- 5 Monarplan contact adhesive
- 6 Monarplan tube washer & fastener
- 7 Monarplan coated metal
- 8 Hot air weld min. 40mm

- 9 Ballast / paving slabs
- 10 Substrate

# Monarplan G Loose Laid & Ballasted



C. Installation of a horizontal perforated galvanized steel rail with 5 fixings / m fixed with the membrane tightly folded back and welded.  
on itself – as close to the rail as possible.

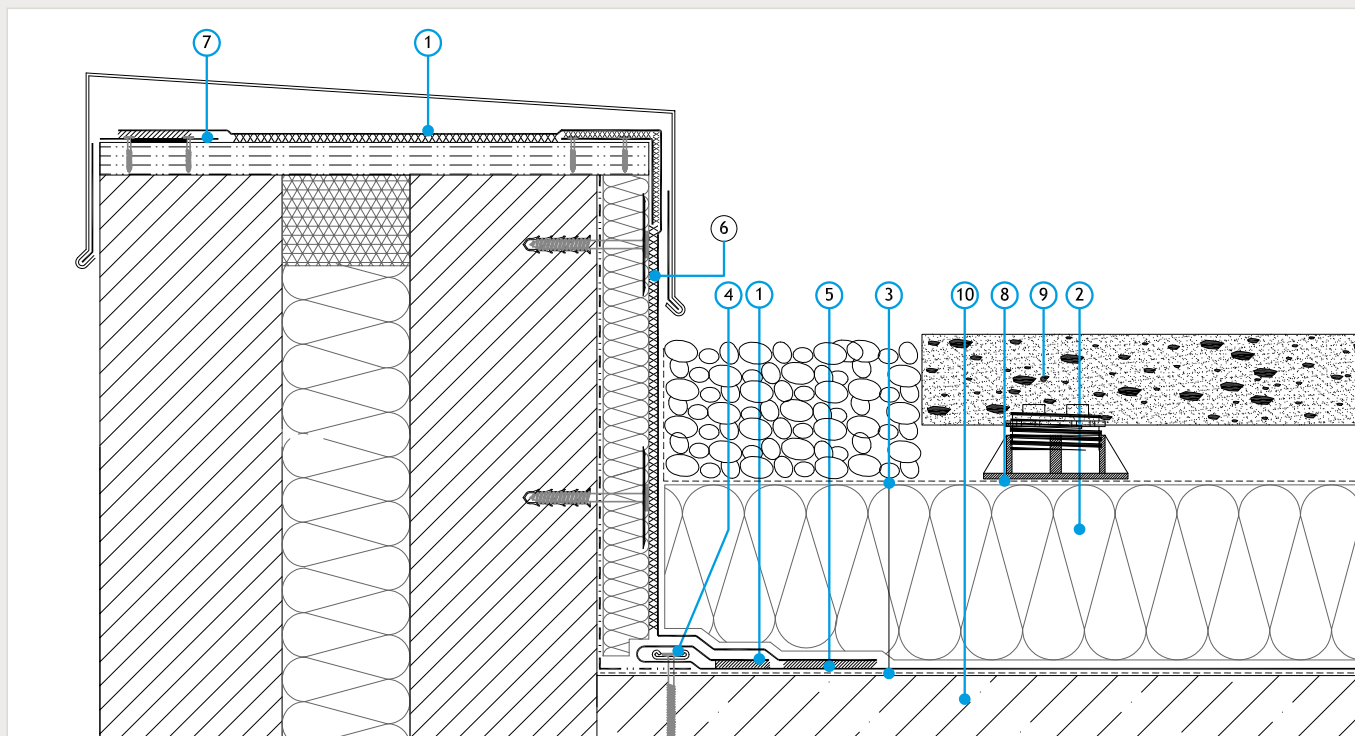

- 1 Monarplan G membrane
- 2 Insulation
- 3 Protection fleece
- 4 Monarplan fixing bar

- 5 Hot air weld min. 40mm
- 6 Monarplan contact adhesive
- 7 Monarplan contact metal
- 8 Filter fleece

- 9 Ballast / paving slabs
- 10 Substrate

# Membrane Application

## Welding – general

Monarplan PVC roofing membranes are hot air welded to each other and to PVC accessories in a homogeneous manner. The welding zone must be clean (free from dust) and dry. All welds shall be a minimum continuous width of 40mm.

The roofing membrane must be unrolled without tension and free of wrinkles. On heat sensitive substrates (eg. foamed insulation boards) and on curved decks (vaults) as well as on soft or uneven substrates, the overlap should be increased according to the situation.

To achieve a good weld, the following criteria should be considered:

- Welding temperature
- Welding speed / traction of the welding machine,
- Volume of air as well as the ambient temperature
- Membrane temperature
- Water absorption

## Hot air welding

All joints in the Monarplan roofing system are hot air welded. It is recommended that automatic welders are used for all field joints. Manual hand held welders should be used for details and inaccessible areas only.

**The figures below act as a guideline (at standard conditions 20 °C, relative humidity of 60%):**

### ■ Automatic welding machine:

Air temperature	480 °C
Traction	2m/min

### ■ Manual hot air welder:

Air temperature	360 °C.
-----------------	---------

Welding temperatures will vary dependant upon the weather conditions of the day. To check the correct welding settings have been achieved, hold the nozzle approximately 10-20mm above the surface of the membrane. If the membrane finish turns 'shiny', the correct temperature has been achieved.

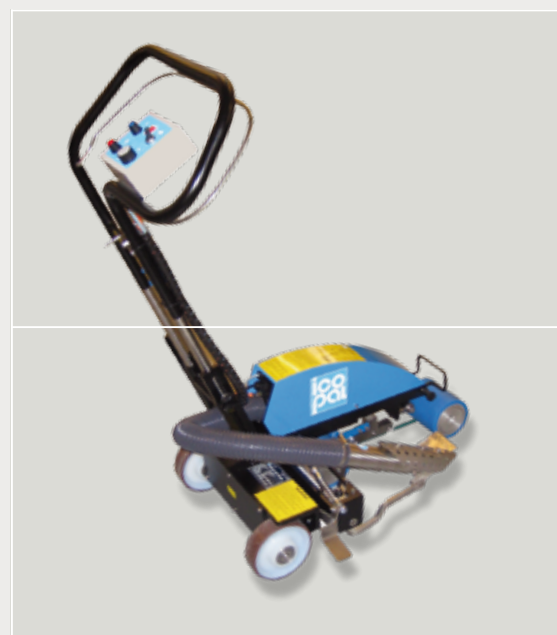

# Membrane Application

## Welding operation – automatic welders

Position the automatic hot air welding machine with the pressure wheel approximately 3mm over the weld edge to ensure a sealed edge. Lift the overlapping membrane sheet and insert the blower nozzle between the overlap. Immediately begin moving the machine along the lap to prevent scorching of the membrane. At the end of the run, remove the nozzle first and then stop the machine's forward motion. When the automatic welder moves over an insulation plate, insulation step off, lap crossover, etc., these areas should immediately be handrolled to ensure a complete weld.

## Welding operation - hand welder

Use a hand-held welder and silicone covered roller to complete welds and details where the automatic welder is inappropriate.

When the parameters are adjusted correctly, a fine bead of molten (mostly dark) material of the sheet's underside becomes visible outside the upper membranes edge. When welding, there is a certain development of smoke and the surface of the lower sheet turns shiny – brilliant when heated correctly. A change of colour or the formation of ashes on the nozzle or the welding zone indicates that the welding temperature is too high.

When there is a risk of wrinkles or sliding of strips and sheets, it is advisable to provisionally stitch (spot weld or pre-weld) the two sheets every 20 – 30 cm.

The weld must have a minimum width of 40mm. This avoids a local peak of peel forces under wind uplift at isolated areas where there are sudden changes of width.

## Welding - working conditions

For hot air welding there is no general limit for working at lower temperatures. It is crucial that the sheet can be rolled out without wrinkles and the temperature difference between the membrane and the hot air does not become too great (this leads to wrinkles outside the welding zone).

When stored in a warm or heatable location the material should have a temperature of at least +5°C – 15°C (ideally 10). When the waterproofing is installed roll by roll, work can proceed at very low temperatures – general conditions for welding apply – i.e. welding parameters and tests.



# Membrane Application

## Welding - tests

Before starting work on site (morning and afternoon) and whenever there has been a change in the weather conditions, the welding parameters have to be verified and adjusted accordingly by carrying out a welding test. This is a site test and samples are torn by hand in the absence of a calibrated peel tester in the lab.

### Width of the sample:

- Welding machine >50 mm
- Manual Hot air welders >20 mm

The requirement for a good weld is that the peel resistance / shear resistance is greater than the inter-laminar adhesion between the top and bottom PVC layers.

The peel test (by hand) shall not be carried out before the sample has cooled down to ambient temperature. Prior to performing the peel test, cut the sample material into strips 20 mm wide. The samples shall be torn by hand in lengthwise and crosswise direction respectively. When there is a delamination of either the top or bottom sheet the requirement is fulfilled and the welding parameters are set correctly. The delamination means a controlled destruction of the product.

When the seam peels off without a delamination of the membrane layers, it is indicated that the welding parameters were insufficient. A visual check can give a lead to whether:

- The air temperature was too low

## Welds - checking of seams

Checking the seams is a compulsory action at the end of any area of work. The welded seams have to cool down to ambient temperature. Tool: Seam probe. The tool shall slide along the seam with little pressure continuously. When a deficient weld is detected, it should be immediately visibly marked and repaired as soon as possible. Always use a patch of 100 x 100mm minimum with rounded edges. When the deficiencies are "long" cut the patch to the size of the problem zone plus a 50 mm perimeter overlap. Circular patches shall have a diameter of 100 mm min.

**Never use liquid PVC to repair poor welds.**

## Deficiencies

Wrinkles, capillaries and fish-mouths are to be avoided. When these deficiencies occur they shall be repaired immediately.

## Seam sealant

The use of sealant to seal cut edges is not required. Monarplan's unique anti-wick reinforcement eliminates the need of such action.

## Notice

Complete all roofing work and flashing each day to prevent water from getting under completed roof sections. Any areas where water has penetrated the completed roof must have any moisture and wet insulation removed.

Temporary sealing of the edge of the roofing membrane is the responsibility of the contractor. The tie-off must be higher than the drain, and slope to the drain.

# Membrane Application

## T-joints & cross-joints

At T-joints, the thickness of the middle sheet has to be chamfered back to “zero” with a chamfering tool or the 40mm flat nozzle of the hot air gun. In order to minimize this operation it is advisable to round off the edge or cutting off a triangle of the middle sheet or to weld the two lower membranes over the width of the overlap.

On the other side a cross seam meets a continuous sheet below. The edge of the middle sheet should also be rounded or cut off.

When planning the layout of the sheets cross-joints should be avoided. When the roof is long or when this should prove to be too arduous a membrane strip of min. 300 mm width shall be centered and welded over the overlap. Treatment is similar to that of T-joints.

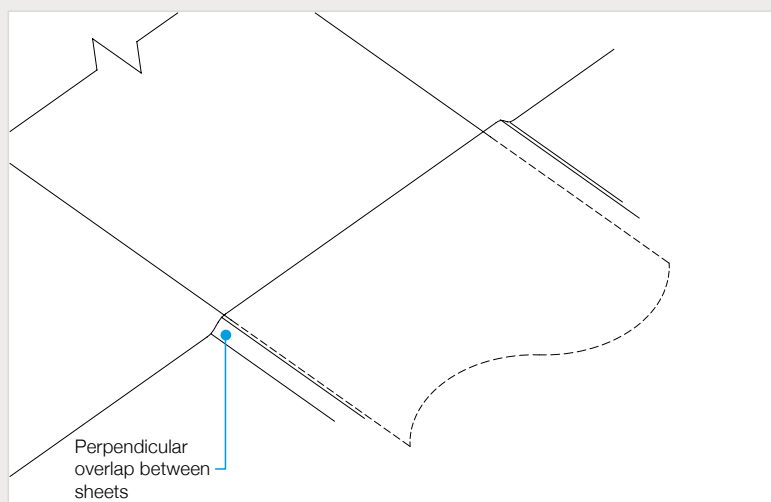

### Step 1

T-Joint is created between perpendicular sections of Monarplan membrane

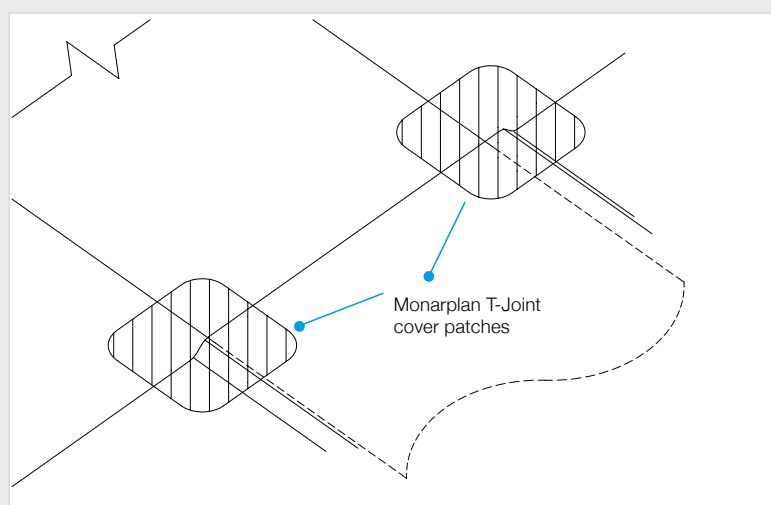

### Step 2

Sections of Monarplan membrane are welded over the T-Joint as a cover patch

# Monarplan Accessories



## Contact adhesive

Monarplan Contact Adhesive is a solvent based adhesive. For best results apply adhesive to both surfaces to be bonded and allow to dry for approximately 30-40 minutes. Using a rubber / metal roller, roll the surfaces together for maximum adhesion.

## Fleeceback adhesive

Monarplan Fleeceback Adhesive is a polyurethane based adhesive used to adhere Monarplan GF Fleeceback membrane. The adhesive is applied using a squeegee and subsequently rolled to achieve uniform coverage. It does not offer instant contact adhesion and requires to be continually rolled in 15 minute intervals until 45 minutes have elapsed.

## Rooflights with rigid PVC upstands

A preliminary welding test is strongly recommended to establish the correct parameters prior to installation. Check for instructions of the skylight manufacturers to avoid stresses deriving from wind loads. The membrane should be mechanically fastened around the roof penetration in the same manner as for perimeter fixings prior to welding to the PVC upstand.

## Vertical terminations & fixing bars

Terminate the membrane to the specified height, ensuring a minimum 150mm height is maintained. Where units on kerbs can be raised, it is recommended that the curbs be raised to achieve the 150mm minimum height.

Terminate the top of all flashing as per the Monarplan details. Where the flashing is not protected by a cover flashing, a surface mounted Termination Bar must be installed. Flashing must not be installed over weep holes or damp proof courses in brick walls. Terminate flashing just below weep holes and damp proof courses.

Use Monarplan Fixing Bar to mechanically fasten Monarplan membrane at perimeters, angle changes etc or when using a peel stop detail.



# Monarplan Accessories



## Drainage

Ponding water will not have any detrimental affect on the Monarplan PVC membrane, however it is recommended that roofs be designed with falls (minimum 1:80) to remove water from the roof in accordance with BS 6229. To achieve this a design fall of 1:40 / 1:60 should be considered.

All areas of the roof and the gutters / valleys have to be sufficiently drained. The corresponding number of rainwater outlets and overflows as well as their adequate diameter shall be ascertained prior to application of the Monarplan system.

### Monarplan roof outlets – new warm roof

- Install the Monarplan VCL spigot to the structural deck and secure the vapour control layer to the spigot using Monobond LT tape for polyethylene membranes or hot air application for bituminous membranes.
- Insert the Monarplan roof outlet into the lower spigot section (spigot length can be cut to accommodate the appropriate insulation depth).
- Mechanically fasten the base plate.
- Weld the Monarplan roof outlet flange to the field membrane.
- Install the Monarplan Universal® leaf grate.

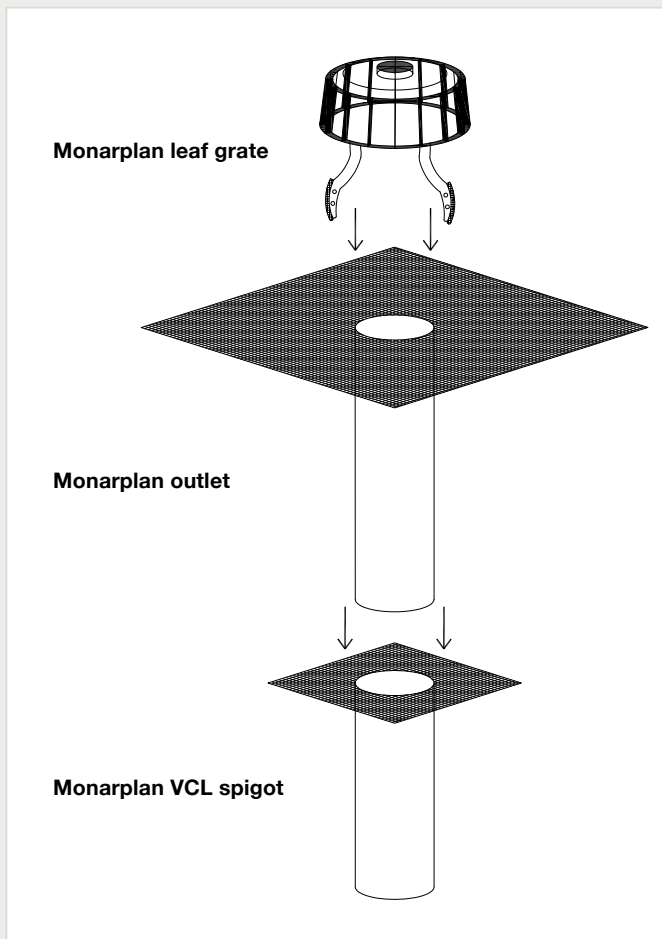

# Monarplan Accessories



## Monarplan refurbishment outlets - overlays

- Attach the anti-back flow rubber ring to the spigot and slide the outlet into the existing rainwater outlet.
- Mechanically fasten the base plate.
- Weld the Monarplan roof outlet flange to the field membrane.
- Install the Monarplan Universal® leaf grate.

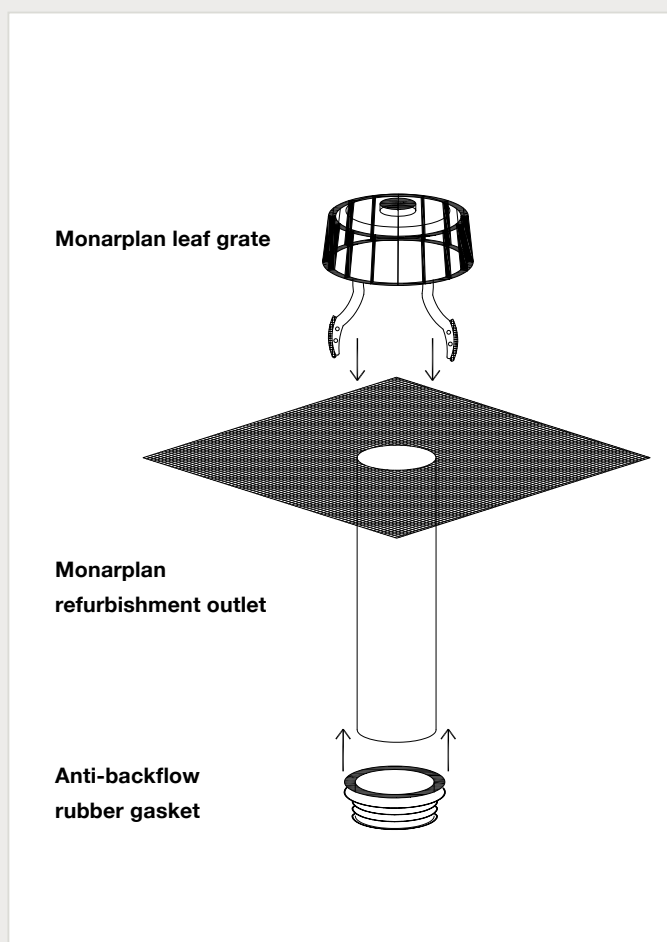

# Monarplan Accessories

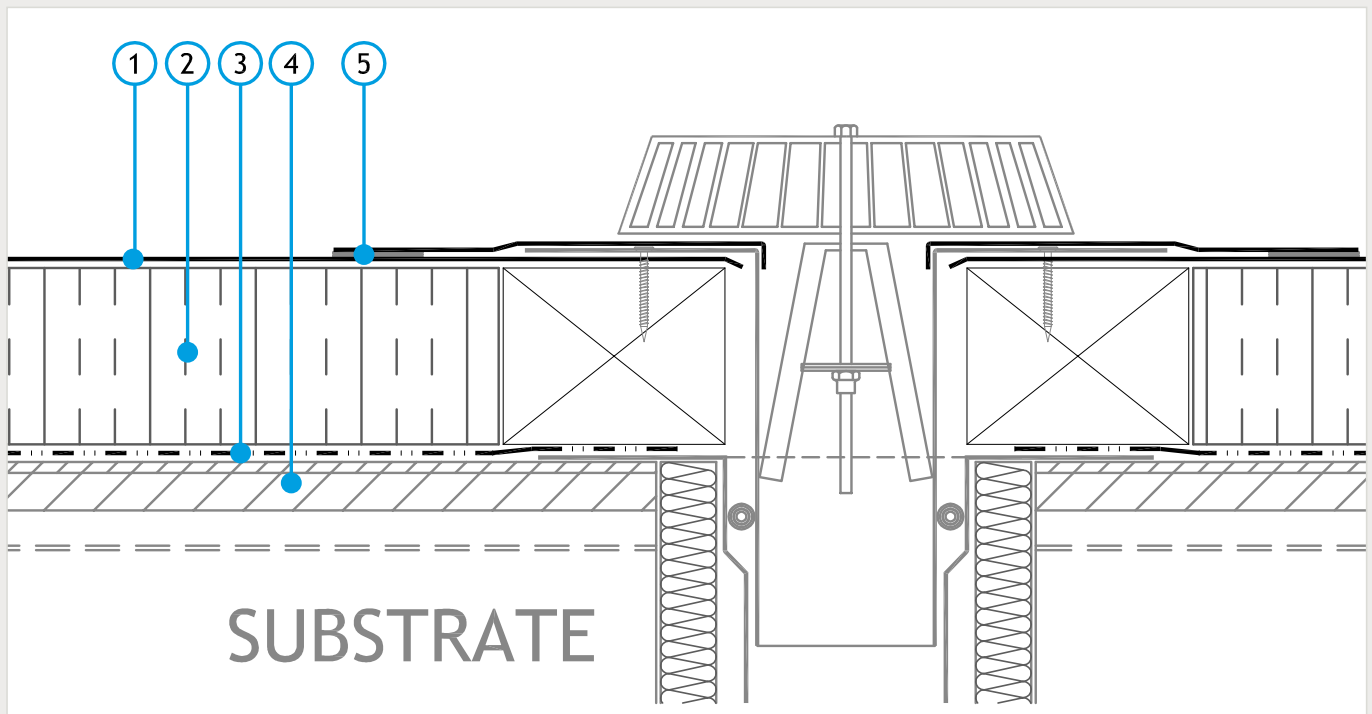

- 1 Monarplan membrane
- 2 Insulation
- 3 Vapour control layer

- 4 Substrate
- 5 Hot air weld min. 40mm

# Monarplan Accessories



## Monarplan parapet outlets

- Insert the Monarplan parapet outlet into the pre-cut hole through the parapet.
- Weld the Monarplan parapet outlet flange to the membrane on adjacent upstand.

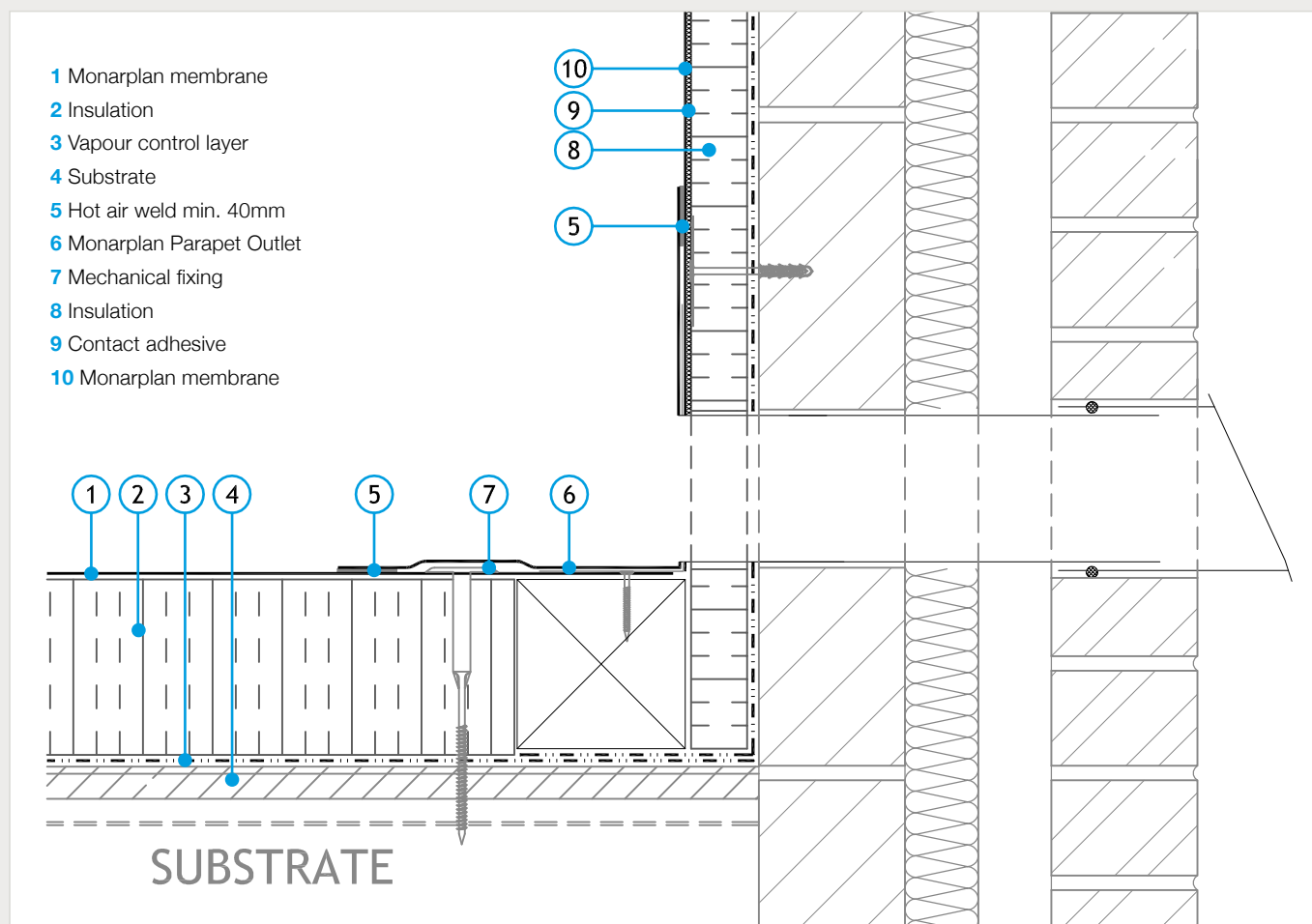

## Gutters

Gutters can be lined using Monarplan membrane in conjunction with Monarplan coated metal. All gutter designs shall be in accordance with BS EN 12056: 3.

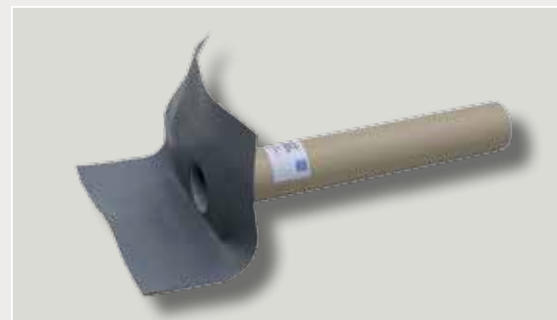

# Monarplan Accessories



## Pipe penetrations

- 1 Use Monarplan pre-fabricated pipe boots where possible.
- 2 Remove any existing lead flashing, old paint, and rust where applicable and clean surface to receive membrane flashing.
- 3 Cut pre-fabricated pipe boot to the appropriate pipe diameter and slide into position.
- 4 Install mastic sealant between the Monarplan Pipe Boot and the pipe and secure with a stainless steel clamping ring (eg. jubilee clip).
- 5 Where pre-fabricated pipe boots are not practical, wrap the pipe with unreinforced Monarplan D in accordance with the appropriate detail.

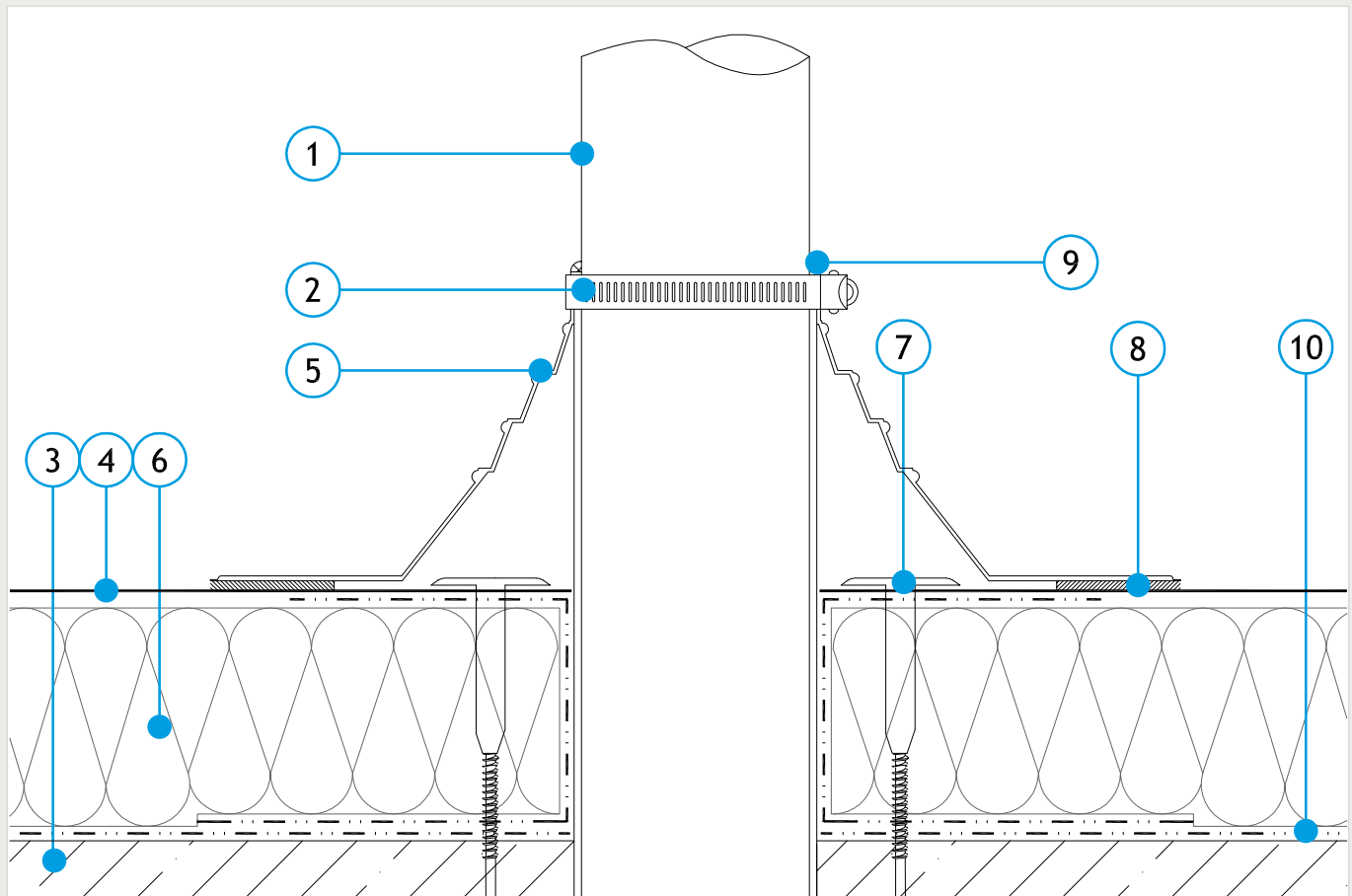

- |                                       |  |
|---------------------------------------|--|
| 1 Pipe $\varnothing$ 25-150mm         | 6 Insulation                           |
| 2 Stainless steel clamping ring       | 7 Monarplan PVC tube washer & fastener |
| 3 Substrate                           | 8 Hot air weld min. 40mm               |
| 4 Monarplan PVC membrane              | 9 Monarplan PVC mastic sealant         |
| 5 Monarplan pre-moulded pipe flashing | 10 Vapour control layer                |

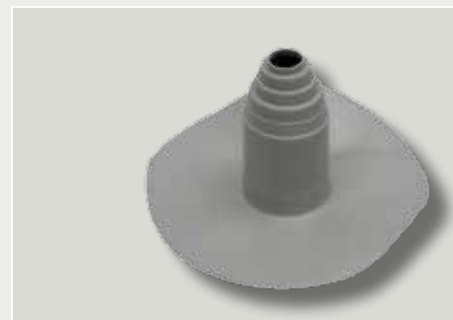

# Monarplan Accessories



## Hot pipes

Pipe penetrations that exceed 50°C require an oversize insulated sleeve to flash to.

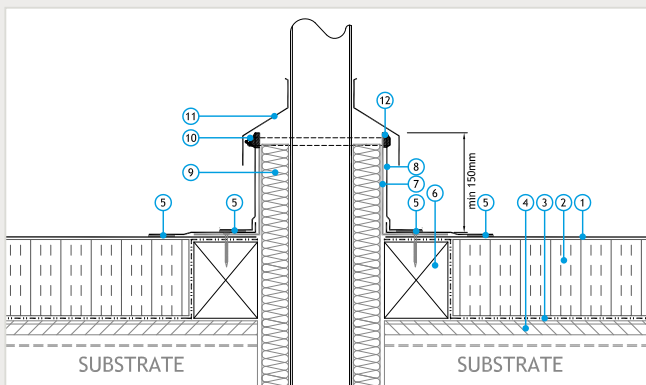

## Standing seams

Demarcate Monarplan Standing Seams at required centres. Position Monarplan Standing Seams and weld to the Monarplan PVC Membrane.

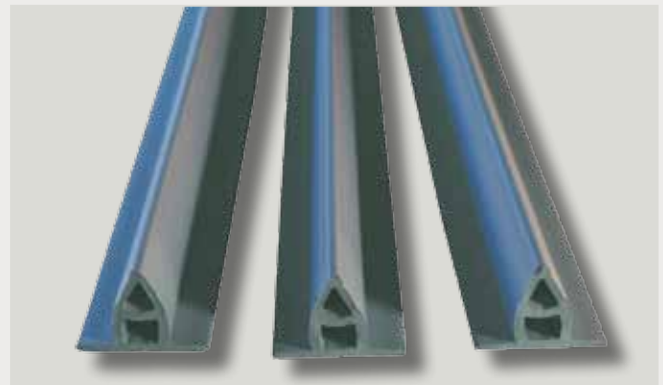

## Walkways

Install walkways as designated by the specifier. The installation of either plywood or metal sheeting wrapped in protection fleece under the membrane should be considered to prevent compression and damage to the insulation due to heavy traffic.

Position the Monarplan Walkway rolls and weld down the edges leaving breaks where laps in the waterproofing membrane below are crossed and intermittently for the purposes of drainage.

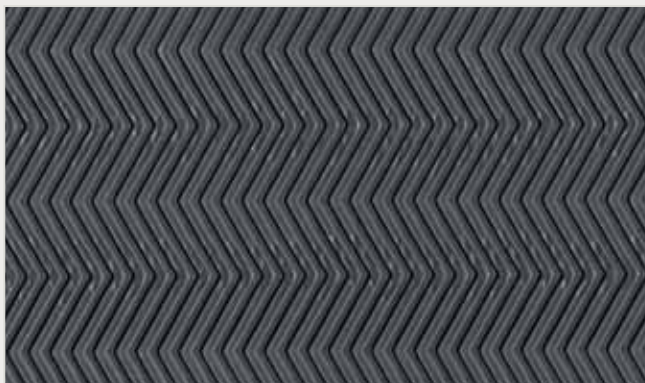

## Corners

Where possible Monarplan pre-fabricated internal and external corners are recommended. Weld the pre-fabricated corners into position after the membrane has been installed.



# Monarplan Accessories



## Lightning conductor pads

Monarplan lightning conductor pads are available for bare copper or PVC coated cables. Position the conductor pad at appropriate centres and weld directly to the Monarplan PVC membrane. Clip the cable into the conductor pad.

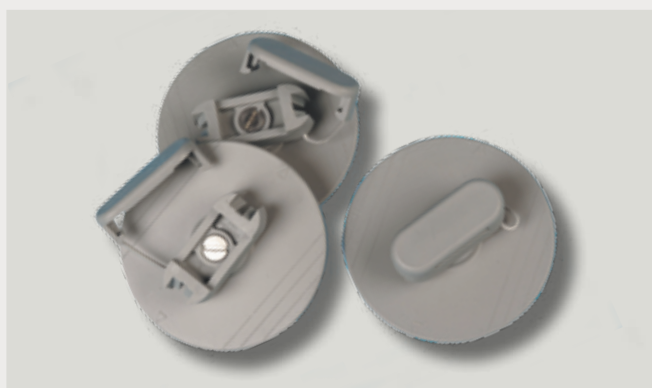

## Unreinforced flashing

Monarplan D is an unreinforced membrane used for site formed details.

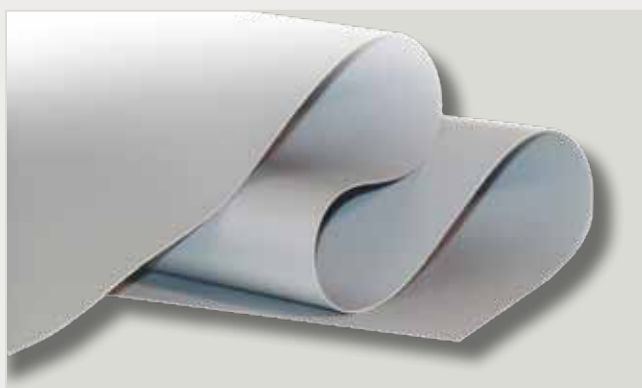

## Cable & tube ducts

Install Monarplan cable duct where cables penetrate the waterproofing system. Place the upstand pipe over the cables centrally. Ensure the Monarplan membrane flange on the upstand pipe is fully supported and heat welded.



## Coated metal

Pre-fabricated sections of coated metal can be used for trims, drips and upstands. Monarplan membrane is laminated to sheet steel.

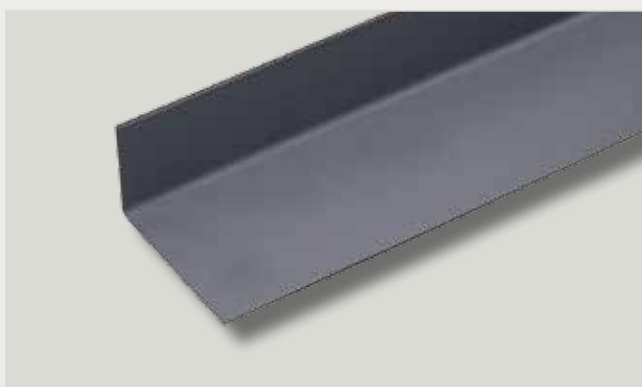

# Monarplan System Components



## Vapour control layers

The presence of a vapour control layer helps to maintain the airtightness of the roof. Part L of the building regulations stipulates that compliance is achieved where a permeability to air figure not exceeding  $10\text{m}^2/\text{h}/\text{m}^2$  at 50Pa.

### Metal decks - loose laid polyethylene membrane

Lay Monarflex vapour control layer (eg. Netofol, Monofilament 250, Reflex 275) without folds or wrinkles allowing for minimum 100mm side and end laps. Seal all laps with Monobond LT Tape (15mm). Turn the vapour control layer up all upstands, kerbs and penetrations etc. to maintain an air tight barrier.

### Concrete / timber decks – fully adhered bitumen membranes

Prepare concrete surface using Xtra-Seal SF Primer. Install Micoral SK Layer ensuring minimum 100mm overlaps. Where external temperatures dictate (ie. cold temperatures), the use of a gas torch may be required to facilitate adhesion. Seal all laps and turn the vapour control layer up all upstands, kerbs and penetrations etc.

*NB: Micoral SK VCL may be used above a metal deck where it is necessary to achieve a temporary watertight roof prior to single ply membrane installation.*

*Refer to Icopal's technical department for details.*

## Insulation

Install only as much insulation as can be covered by the completed roofing system by the end of the day. Surfaces shall be smooth, clean, dry and free from contaminants.

- A. Fit insulation neatly at all perimeters and penetrations with gaps and steps not to exceed 6mm. Voids greater than 6mm must be filled with insulation.
- B. Stagger end joints between boards. When installing multiple layers, offset joints between layers.
- C. Fasten the insulation where required with acceptable fastener assemblies.
- D. On metal decks, boards shall be laid with long edges at  $90^\circ$  to the deck troughs with end joints fully supported on the crowns.

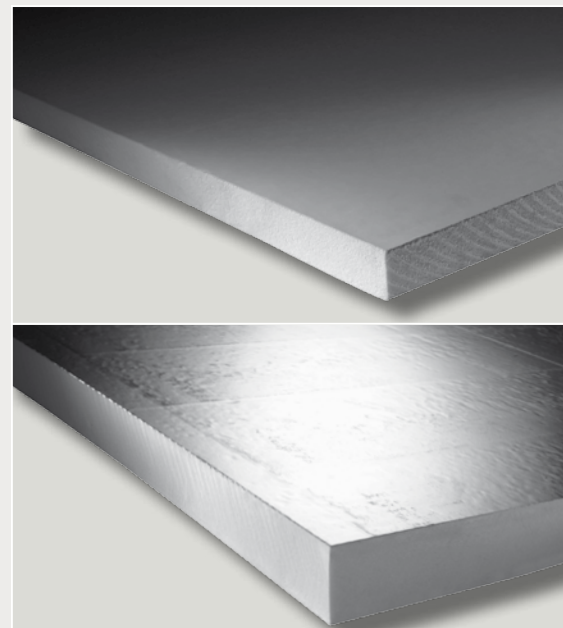

# Monarplan System Components



## Protection, separation and levelling layers

In many roof applications, the roofing membrane has to be separated from other incompatible elements or protected against mechanical damage. In some cases free movement between layers has to be allowed for (in-situ [reinforced] concrete or ceramic tiles in mortar bed). Where this is the case, a geotextile separation or protection fleece should be installed as part of the roof build up.

### Separation layers

In order to avoid migration of plasticizers, separation layers are necessary when Monarplan is applied onto non compatible substrates such as polystyrene insulation boards or bituminous felts (old or new). Separation layers cannot be used as protection against incompatible substances such as oil, fuel, fats, solvents and many other chemicals.

Geotextiles such as non-woven's made of Polyester, PP or a mix of PES and PP can function as these layers. Polyester shall not be used when an alkaline environment is likely (eg. freshly poured concrete or concrete washed out).

On Polystyrene insulation, a glass fleece is recommended in order to improve the fire resistance. In this case, a 120 g/m<sup>2</sup> fleece membrane will be sufficient (eg. Monarplan Separation Fleece).

### Protection layers

Protection layers are required for the mechanical protection of the roofing sheet prior to the application of roof ballast or green roofs. A polyester geotextile (eg. SLP 300 Protection Fleece) approximately 300 g/m<sup>2</sup> will protect the Monarplan membrane whilst also acting as a filtration layer. Overlaps shall be with the fall of the roof and in excess of 200mm.

### Levelling layers

Levelling layers are installed between rough and /or uneven substrates and the water proofing layer (generally above tamped concrete surfaces).

The geotextiles shall have a minimum weight of 200 g/m<sup>2</sup> depending on the actual situation on the roof (eg. SLP 300 Protection Fleece). A sufficient resistance against perforation and compression is required.

# Monarplan System Criteria



The Monarplan PVC System will qualify for a materials warranty when pre-approved by Icopal and installed in accordance with the written specification and drawing details.

Pre-approval is obtained by submission of the Project Registration Form prior to commencement of the project. Forms should be sent to Icopal's Technical Department.

The Monarplan PVC Roofing System is appropriate for installation on commercial, industrial and residential complexes. All installations must be reviewed for acceptability by the Icopal Technical Services Department. Special conditions should also be submitted.

Such conditions might include:

- Buildings in high or special wind zones.
- Buildings with large wall openings (greater than 33% of the total wall surface area).
- Buildings subject to interior pressurisation (hospitals, food processing facilities and electronics plants).
- Buildings with high interior humidity (over 45% relative humidity: i.e. pool enclosures, paper processing plants).
- Buildings with a roof slope in excess of 20°.
- Cold storage buildings and freezer facilities.

## Substrates

The load bearing structure must comply with all associated national standards and regulations, ensuring that the load bearing capacity is sufficient for any additional loads imposed upon the construction. It is important to consider the possibility of future deflection of the construction when designing roof drainage.

Substrates must be strong enough to permit the penetration of fixings whilst maintaining suitable pull out strength. It is recommended that pull out tests are conducted prior to the application of the Monarplan system (see below).

## Acceptable substrates

The Monarplan Roofing System can be installed on new construction or over existing roofs, when the existing roofing assembly is dry or the wet areas have been removed and replaced; or when the existing roof is completely removed to the deck. The roofing contractor has the final responsibility of acceptance of the surface to receive the roofing system.

# Monarplan System Criteria



The following structural substrates are acceptable for the Monarplan PVC Roofing System:

## Profiled metal

- Minimum 0.7mm galvanised steel to BS EN 10147: 2000. The minimum requirement to support the Monarplan membrane above the metal deck is insulation boards. In mechanically fixed roof build-ups, it is crucial to ensure that the rows of fasteners are installed in a perpendicular direction to the metal deck's corrugations (or the single timber plank) in order to avoid a concentration of uplift forces on any one single element.

Aluminium decks shall be a minimum 0.9mm BS EN 485-2: 1995 AA3004 H34. Reference should also be made to BS EN 1396: 1997 as appropriate. For mechanically fastened systems, refer to Icopal's Technical Department for confirmation of suitability of fastener.

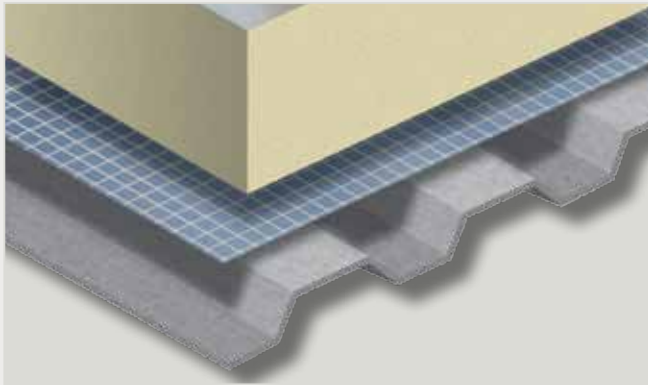

## Plywood or Oriented Strand Board

- New 18mm exterior grade plywood (to BS EN 636-2003: Clause 8) fixed in accordance with the current revision of BS 8217 & BS 6229 ensuring it is of adequate rigidity for the joist spans involved and fixed with corrosion resistant ring shanked nails or screws at 150mm centres to the perimeter of the panels and 300mm along the intermediate supports. Fixings should be well driven to avoid damage to the membrane.

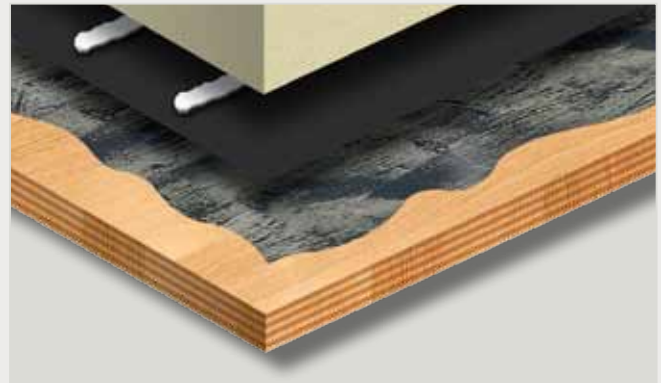

## Timber Boarding

- New timber boarded roof deck in accordance with the current revision of BS 8217, BS 6229 & BS 5268-2. Boarding should not be less than 25mm nominal thickness, planed and clamped together with tongued and grooved joints or closely butted and secured by ring shanked nails or screws at a rate of 2 per board width at both ends and at every intermediate support. Fixings should be well driven to avoid damage to the membrane.

# Monarplan System Criteria



## Structural concrete:

- The reinforced concrete roof slab surface should be finished to provide an even surface free from ridges and hollows. New in-situ cast concrete should be given adequate time to dry out, prior to installing the waterproofing system.



## Other substrates:

- Sprayed in-situ urethane foam – Not Acceptable
- Stramit / Straw Board – Not Acceptable
- Chipboard - Refer to Icopal's Technical Department
- Woodwool - Refer to Icopal's Technical Department

Good roofing practice requires the roof to be free of significant ponding within 48 hours of rainfall. Where the structural deck does not provide drainage or removal of standing water within 48 hours, the substrate should be corrected to provide positive drainage.

It is recommended that all decks in a warm roof construction be sealed prior to installing the roofing system to prevent air infiltration beneath the membrane. Sealing the deck is accomplished by installing a vapour control layer over the deck and sealing around all penetrations.

# Monarplan System Criteria



## Fastener withdrawal resistance criteria

Fastener withdrawal resistance tests are recommended on certain refurbishment projects to determine the suitability of the roof deck. The withdrawal resistance test may be conducted by an independent laboratory or the fastener manufacturer or their designated representative. The results of the pullout tests must be designated on a roof plan to indicate the areas at which the tests were conducted and forwarded to Icopal for review.

On refurbishment projects, a core cutter should be used to remove existing roofing material prior to conducting the withdrawal resistance test (even if the existing roofing membrane is specified to remain). Existing roofing materials will contribute to a higher, misleading pullout value.

The withdrawal resistance tests should be carried out in various locations of the roof deck, such as:

- Roof corners
- At perimeter areas (minimum of 3 each).
- Field of the roof (with at least 2 tests conducted at the low areas of the roof deck).

## Resistance to wind load

The affect of wind upon a single ply roof covering should be determined at an early stage. Wind loads are determined by completion of a calculation as recommended in BS6399: part 2 1997. The calculation will take the following factors into account:

- Geographical Location (eg, coastal, urban, rural)
- Site topography
- Building height
- Building design
- Large openings
- Method of attachment

This calculation must be carried out early on in the design process and is generally done following receipt of the preliminary project registration form.

Completion of the membrane wind uplift calculation will confirm the fasteners centres / spacings for the following roof zones:

- Corners / Perimeter
- Field Area or central zone

The calculation will also confirm the width of the perimeter zone.

Regardless of the type of membrane attachment, mechanical fasteners are always required at the roofs perimeter, angle changes and any details. This ensures that any tensions generated in the field membrane are not transferred to other areas.

In warm roofs, the insulation boards may also be mechanically attached. This should always be kept separate from the attachment of the waterproofing membrane.

Icopal recommends that Thermazone Insulation boards should be secured at a rate of 11 fasteners per 2400 x 1200mm (3.8 fixings/m<sup>2</sup>)

For further clarification on the mechanical attachment of insulation boards refer to the SPRA Design Guide for Single Ply Roofing and BRUFMA. Where alternative insulation boards are used refer to manufacturer's recommendations.



# Monarplan System Criteria



## Chemical compatibilities

Particular care shall be taken to ensure that certain materials and substances do not come into contact with Monarplan membranes. The following brief list of products are not compatible with Monarplan PVC roofing membranes (amongst others):

- Bitumen
- Tar
- Polystyrene
- Fats
- Oils and crude oil products
- Solvents.

For confirmation of any other material compatibility queries, please contact Icopal's Technical Services Department.

## Other manufacturers' products

The use of other manufacturers' materials and accessories which become an integral part of the water proofing system shall be avoided. As an exception to this rule Icopal can individually approve other materials for a single project.

Examples:

- Rainwater outlets
- Ready-made accessories
- Adhesives

This clause also refers to membranes and fleeces which are attached to the Monarplan PVC roofing membranes by bonding or weight of ballast or roof plant.

Examples:

- Walkway sheets or pads,
- Anti-slip sheets, protection mats placed beneath roof plant & equipment,
- Mats of granulated rubber or other anti-vibration materials.

Prior to installation, the chemical compatibility must be proven and the product has to be approved by Icopal or supplied by them.

## Quality assurance

Please note; the validity and the extent of the warranty will only apply where Monarplan membranes and accessories (or products made by others approved by Icopal) have been used. Any alterations to agreed system specifications shall render any warranty offer null and void.

Furthermore, should the Monarplan system fail to be installed in accordance with the current guidelines (unless otherwise agreed), the warranty offer shall be rendered null and void.

Installation shall be by an Icopal approved Monarplan PVC contractor.

The roof will be inspected by an Icopal representative during and on completion of the project.

## Material storage

All single ply membranes must be stored horizontally on a clean flat level surface, undercover and away from direct sources of heat. The rolls are usually individually with protective film. If internal storage is not possible, rolls must be suitably secured and protected.

Icopal Thermazone Insulation Boards are supplied in shrink wrapped polythene which will provide limited protection during unloading and handling. All board packs are clearly marked with date/time of manufacture, board type and thickness for ease of identification. Ideally, boards should be stored inside a building or undercover. If, however outside storage cannot be avoided, boards should be stored flat and off the ground. Full protection in the form of tarpaulins or heavy gauge waterproof sheets must be provided at all times whilst on site. Boards that have been allowed to get wet must not be used.

# Monarplan System Criteria



## Maintenance

The following care and maintenance requirements are for Monarplan Membrane Roofing Systems. Icopal recommend that your maintenance staff and/or maintenance contractor inspect the roof periodically or at least twice a year (as per the recommendations given in Annex B BS 6229: 2003) ideally before and after the winter period. This ensures that dirt and debris is removed before causing damage and that signs of any failure can be reported and remedial action taken at an early stage. Maintenance items are the responsibility of the building owner and are not included within the scope of the Roofing System Warranty.

Item	Action
<b>Internally</b>	Check internal surfaces visually for signs of moisture, leakage or condensation (e.g damp patches, staining etc)
<b>General</b>	Remove any unnecessary debris from the roof area particularly objects, which could cause damage to the membrane. Do not use the roof as a working platform for adjoining buildings or further works. If access is required adequate protection must be provided so as not to damage the membrane.
<b>Drainage</b>	Keep the roof surface clean at drain areas to avoid clogging. Clear leaves, silt or other debris, which may cause blockage of outlets or otherwise impede drainage. Check that ponding water is drained from the roof within 48 hours following rain.
<b>Laps</b>	Visually check the membrane laps for securement.
<b>Petroleum Products</b>	Keep all petroleum products (solvents, greases, paints, oils, or any liquids containing petroleum products) off the membrane to avoid degradation.
<b>Animal Fats</b>	Do not exhaust kitchen wastes (vegetable oils) or other animal fats directly onto the roof surface. They could degrade the membrane.
<b>Chemicals</b>	Contact Icopal if any chemicals come in contact with the roofing membrane. Some chemicals could degrade the membrane or cause swelling.
<b>Foot Traffic</b>	Walkways must be provided if regular traffic is required or if rooftop equipment has a regular thirty (30) day or less maintenance schedule. Exercise caution when not walking on walkways, especially on white membranes since ice or frost build-up may not be visible. Membranes are slippery when wet.
<b>Roof Alterations</b>	Check with Icopal that the proposed alteration will not invalidate the warranty. Work must be carried out by the approved roofing contractor who carried out the original installation. Do not allow other trades to fix through the waterproofing membrane without proper advice. This is especially important when having aerials, heating & ventilation equipment or telephone cables fitted.
<b>Cleaning</b>	Handprints, footprints, general traffic grime, industrial pollutants and environmental dirt may be cleaned from the surface of the membrane using membrane cleaner, then rinsing with clean water. To maximize reflectivity, white membrane(s) should be cleaned once every two years.
<b>Metal Work</b>	Keep roof maintenance items, such as counterflashing, metal curbs and metal ducts sealed watertight at all times.
<b>Leaks</b>	Report leaks immediately to Icopal. Try to determine if it is a roof membrane leak or a wall, curb, skylight, metal ductwork or plumbing leak. Deterioration or failure of building components that causes a leak is not covered by the warranty. A water leak may be indicated by soft or warped insulation or the presence of water under the membrane. Physical damage to the membrane or flashing is not covered by the warranty. Please notify Icopal's Warranty Services at 0161 865 4444 if the leak is determined to be membrane related. The building owner is liable to the cost of investigation and repair if the problem is found to be outside the scope of the waterproofing warranty.
<b>Temporary Repairs</b>	Use a good grade sealant to make temporary repairs. Notify Icopal of this action in writing.
<b>Rooftop Maintenance</b>	When it is necessary for workers to be on the roof to service rooftop equipment, e.g., HVAC units, antennas, etc., workers should be cautioned to use walkways and to exercise care with their tools and equipment to avoid puncturing the roofing membrane.
<b>Roof Cement</b>	DO NOT USE ROOF CEMENT to repair or install membrane. Roof cement contains petroleum products, which may degrade the membrane.

# Monarplan System Criteria



The inspection should concentrate on high-risk areas such as roof hatches, drains and around all rooftop equipment as well as general inspection of the entire roof. The inspector should be looking for membrane damage (cuts and tears), oil or Freon leaks, chemical spills, or water infiltration into the roofing system.

Compliance with the above listed care and maintenance requirements will aid in assuring a durable, watertight membrane roofing system.

## Integrity testing

Upon completion of the Monarplan PVC single ply roof, it is the contractor's responsibility to carry out a non-destructive integrity test to ensure the roof membrane is 100% watertight. Further information concerning such tests can be found in SPRA Guidance Document 09 - Non-Destructive Testing of Single Ply Membrane Roof Coverings.

# Appendix A

## Fastener & Tube Combinations



### A1. Steel deck applications

- Minimum deck penetration to be 20mm
- 4.8mm fastener diameter

Insulation Thickness (mm)	Monarplan Fastener Length (mm)	Monarplan Tubular Washer Length (mm)
60	50	35
70	60	35
80	50	55
90	60	55
100	70	55
110	80	55
120	50	95
130	60	95
140	70	95
150	80	95
160	90	95
170	50	145
180	60	145
190	70	145
200	80	145
210	90	145
220	100	145
230	110	145
240	120	145
250	130	145
260	140	145

### A2. Plywood deck applications

- Minimum deck penetration to be 20mm
- 4.8mm fastener diameter

Insulation Thickness (mm)	Monarplan Fastener Length (mm)	Monarplan Tubular Washer Length (mm)
60	70	35
70	80	35
80	70	55
90	80	55
100	90	55
110	100	55
120	70	95
130	80	95
140	90	95
150	100	95
160	110	95
170	70	145
180	80	145
190	90	145
200	100	145
210	110	145
220	120	145
230	130	145
240	140	145
250	150	145
260	140	145

# Appendix A

## Fastener & Tube Combinations



### A3. Aerated concrete deck applications

- Minimum deck penetration to be 60mm
- 8.0mm fastener diameter

		Roof Build Up Depth					
		Monarplan tubular washer (mm)					
		35	65	105	165	225	
Roof build up depth	Monarplan fastener (mm)	100	60	90	130	190	250
	120	80	110	150	210	270	
	160	120	150	190	250	310	
	200	160	190	230	290	350	
	240	200	230	270	330	390	

### A4. Dense concrete deck applications

- Minimum deck penetration to be 30mm
- Drill depth to be 45mm 6.3mm fastener diameter Pilot hole diameter to be 5mm

		Roof Build Up Depth					
		Monarplan tubular washer (mm)					
		35	65	105	165	225	
Roof build up depth	Monarplan fastener (mm)	35		50	90	150	210
	60	50	80	120	180	240	
	70	60	90	130	190	250	
	80	70	100	140	200	260	
	100	90	120	160	220	280	
	120	110	140	180	240	300	
	140	130	160	200	260	320	
	180	170	200	240	300	360	
	220	210	240	280	340	400	