



Building industry expertise since 1889

BUILDERS
METALWORK



Welcome to this latest guide from Expamet – the brand you can always rely on

Expamet products are developed to ensure high levels of performance, ease of use and fast, accurate installation. Our extensive range is designed to meet the complex demands of individual projects whilst saving time and cost.

Expamet building products are available nationwide via all major builders merchants and distributors. We operate a guaranteed fast ordering process over a nationwide UK network.

Working outside the UK?

No problem. We have a strong presence across Europe and the Middle East. For your nearest supplier, just call us on +44 (0)191 411 2244 or Email us at expamet.sales@birtleygroup.co.uk

Need technical advice?

Call our expert team on 0845 121 2260 and they'll be pleased to help.



Birtley Group

STRENGTH THROUGH QUALITY

One Group. Three outstanding brands



The famous Birtley, Expamet and Bowater brands are now working together within Birtley Group. A combined strength which is adding value to projects across the UK through quality, innovation and higher service levels than ever before.

That's Birtley Group commitment.

www.birtleygroup.co.uk

Don't forget these other outstanding Expamet product ranges:

Plasterers Accessories

A range of metal and pvc beads and lath to suit any application

BAT Windpost Systems

Designed on a project-by-project basis to meet exact requirements.

BAT Masonry Support

Bracket and angle support systems can be tailored to meet individual designs.

Hy-Rib

Permanent Formwork

Proven through over 80 years in many prestigious building projects.

- 4 SPH Joist Hangers
- 6 Maxi Speedy Joist Hangers
- 8 Speedy Joist Hangers
- 10 Restraint Straps
- 12 Joist Struts
- 13 Truss Clips
- 14 Framing Anchors
- 15 Angle Plates
- 16 Angle Brackets
- 19 Timber Connectors
- 20 Splice Plates
- 20 Timber Frame Cramps
- 21 BAT-U-Nail Plates
- 22 Multi-Purpose Fixing Bands
- 22 Junction Clips
- 23 Sole Plate Angles
- 23 Safe Plates
- 24 Wall Ties
- 26 Frame Cramps
- 27 Security Mesh
- 28 Exmet Brick Reinforcement
- 29 Flat Wire Reinforcement
- 30 Wall Starters
- 31 Accessories

SPH JOIST HANGERS

The BAT S.P.H. Joist Hanger is a single piece timber to masonry hanger for building into the inner leaf of external cavity walls and internal walls.

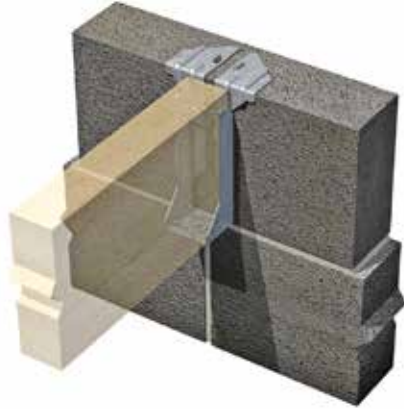

Design Features

- Single-piece, non-welded construction.
- Wider masonry flange to increase loadings on masonry of compressive strength 2.8N/mm² and greater.
- Manufactured from 2mm thick pre-galvanized mild steel to BS EN 10346 : 2015, DX51D + Z600.
- 75mm load bearing surfaces.
- All hangers 150mm deep and over are manufactured 10mm less to allow for notching and regularisation of timber joists.
- Gusset nail holes are non coaxial.
- Standard available widths 38, 44, 47, 50, 63, 75, 89, 100, 125, 150mm.

Installation Requirements

The back face of hanger must be flush against the wall.

The timber joist should be square cut and butting to the back face of the hanger (maximum permitted gap 6mm).

A minimum height of 675mm of set masonry must be in position above the supporting flange before any load is applied.

Fixing: Nail to the joist through the nail holes in each side gusset with BAT 3.75 x 30mm long square twisted sherardised nails.

It is recommended that joists are notched for the base of the hanger to achieve a level surface for plasterboarding.

Type 'R' and 'ST' provide additional location and alignment during construction.

HD Restraint Straps must be used with all types of SPH joist hangers if lateral restraint is required.

SPH JOIST HANGERS

How to Order/Specify

TYPE 'S'

Please state dimensions of joist

- depth
- width e.g. SPHS22550

Minimum box quantity dependent on hanger size.

TYPES 'R' & 'ST'

(made to order)

Please state dimensions of joist

- depth
- width
- top flange (to suit wall width) e.g. SPH22550R100

Quantity made to order



Standard type 'S'

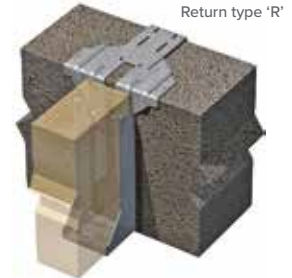

Return type 'R'



Straddle type 'ST'

Vertical load capacity (kN) – 3.5N/mm² masonry (SWL shown in brackets)

Joist Height	100	125	150	175	200	225	250	275
Width 38	10(5)	10(5)	10(5)	10(5)	10(5)	10(5)	10(5)	10(5)
Width 44	10(5)	10(5)	10(5)	10(5)	10(5)	10(5)	10(5)	10(5)
Width 47	10(5)	10(5)	10(5)	10(5)	10(5)	10(5)	10(5)	10(5)
Width 50	10(5)	10(5)	10(5)	10(5)	10(5)	10(5)	10(5)	10(5)
Width 63	10(5)	10(5)	10(5)	10(5)	10(5)	10(5)	10(5)	10(5)
Width 75	10(5)	10(5)	10(5)	10(5)	10(5)	10(5)	10(5)	10(5)
Width 89	10(5)	10(5)	10(5)	10(5)	10(5)	10(5)	10(5)	10(5)
Width 100	10(5)	10(5)	10(5)	10(5)	10(5)	10(5)	10(5)	10(5)
Width 125	14(7)	14(7)	14(7)	14(7)	14(7)	14(7)	14(7)	14(7)
Width 150	15(7.5)	15(7.5)	15(7.5)	15(7.5)	15(7.5)	15(7.5)	15(7.5)	15(7.5)

MAXI SPEEDY JOIST HANGERS

The Maxi Speedy is a heavy duty hanger for the support of timber to timber or timber to masonry, concrete, etc. with provision for nailing or bolting.

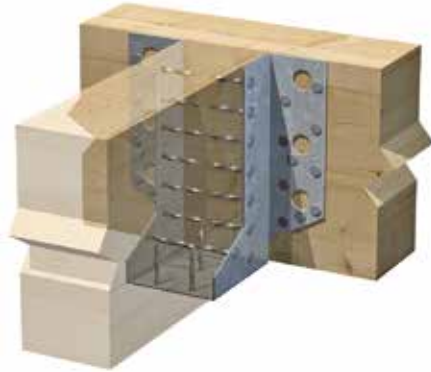

Design Features

- Manufactured from pre-galvanized mild steel to BS EN 10346 : 2015, DX51D + Z275.
- Available in 7 types: MS240,335,380 - 1.2mm thick MS440,500,560,620 - 1.5mm thick
- Nail hole diameter : 4.5mm
- Bolt hole diameter : 14mm
- Available widths: 38, 47, 50, 63, 75, 100mm (122 + 150 for MS500, 560 + 620 only)

Installation Requirements

Fixing: use BAT 3.75 x 30mm long square twisted sherardised nails.

M12 Bolts or coach screws as specified by fixing manufacturer.

How to Order/Specify

1. Joist dimensions: Double joist depth and add joist width, ie for joist 225 deep x 38mm wide then: $225 (d) + 225 (d) + 38 (w) = 488\text{mm}$.

2. The Maxi Speedy blank length must be less than total calculated in step 1, therefore select MS44038 (not MS500 as the joist hanger would stand proud).

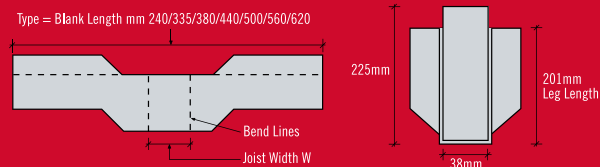

MAXI SPEEDY JOIST HANGERS

Maxi Speedy Dimensions (mm)

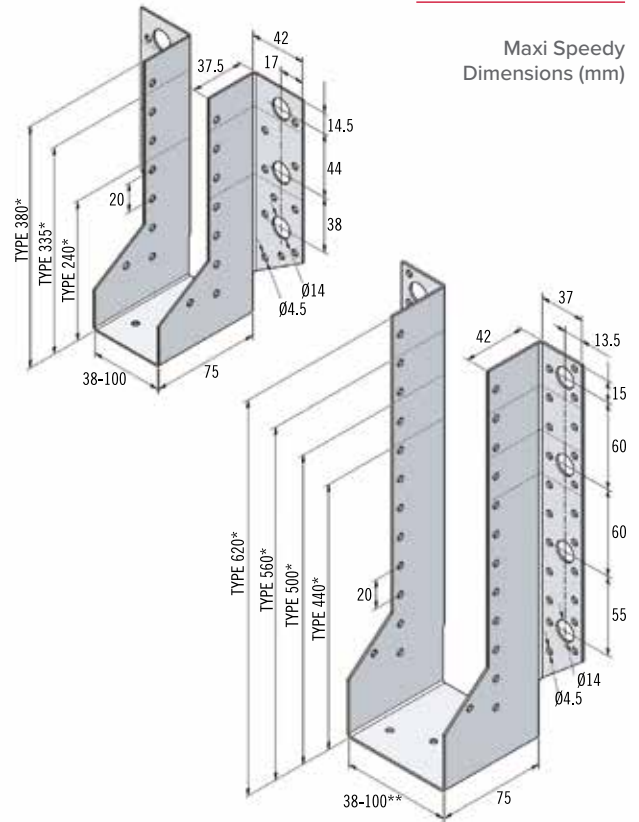

Nail Fixing - Characteristic load capacity Fk (kN) – C24 Timber

Joist Width	38	47	50	63	75	100	122	150
MS240	2.39	2.66	2.77	3.36	4.19	6.67		
MS335	4.87	5.44	5.66	6.86	8.55	11.68		
MS380	6.26	7.03	7.32	8.96	11.30	13.34		
MS440	8.89	9.96	10.37	12.65	15.89	20.31		
MS500	13.15	14.73	15.35	18.73	20.31	20.31	20.31	20.31
MS560	18.59	20.31	20.31	20.31	20.31	20.31	20.31	20.31
MS620	20.31	20.31	20.31	20.31	20.31	20.31	20.31	20.31

Bolt Fixing - Characteristic load capacity Fk (kN) – C24 Timber

Joist Width	38	47	50	63	75	100	122	150
MS240	4.50	5.57	5.92	7.46	8.88	11.84		
MS335	5.98	7.05	7.40	8.94	10.36	14.74		
MS380	7.46	8.53	8.88	10.42	11.84	17.60		
MS440	10.35	11.42	11.77	13.31	14.74	20.10		
MS500	13.27	14.34	14.69	17.06	20.31	20.31	20.31	20.31
MS560	16.75	18.79	19.59	20.31	20.31	20.31	20.31	20.31
MS620	20.31	20.31	20.31	20.31	20.31	20.31	20.31	20.31

SPEEDY JOIST HANGERS

Speedy Joist Hangers provide a quick and safe method of joist trimming for light and medium duty joints.

Design Features

- Speedy Hangers: 0.9mm thick pre-galvanized mild steel to BS EN 10346 : 2015, DX51D + Z275. Hole diameter: 3.8mm. LLS: 1.5mm thick material. SGTS: 1.2mm thick material.



- Girder/Girder Speedy: 3mm thick mild steel galvanized to BS EN 1461. Hole diameter : 22mm.

Fixing: use BAT 3.75 x 30mm long square twisted sherardised nails through all available nail holes.

Speedy joist hangers – available sizes

Joist Width	38	44	47	50	63	75	80	91	100	105	120	155	Maximum Joist Depth
SM	•	•	•	•									100
SL	•	•	•	•									175
ST	•	•	•	•	•	•	•	•	•				225
SGTS	•	•	•	•	•	•	•	•	•				N/A
LLS	•	•	•	•	•	•	•	•	•				225
GGTS										•	•	•	N/A

Characteristic load capacity Fk (kN) – C24 Timber

Joist Width	38	44	47	50	63	75	91	100
Speedy Minor SM	3.2		2.2	2.2				
Short Leg Speedy SL	6.3	4.6	4.6	5				
Standard Leg Speedy ST	8.5	7	6.7	6.7	6.9	7.1	7.1	7.4
Speedy Girder Truss Shoe SGTS	10.7	12.3	12.8	12.6		11.2		
Long Leg Speedy* LLS	7.6		7.6	7.6	7.6	7.6	7.6	9.6

*6.7 kN when underslung by up to 100mm

Speedy Minor

Depth ≤ 100
W = 38 : L = 70
W = 47 : L = 65
W = 50 : L = 64

Short Leg Speedy

Depth ≤ 175
W = 38 : L = 191 : X = 76
W = 44 : L = 188 : X = 73
W = 47 : L = 186 : X = 71
W = 50 : L = 185 : X = 70

SPEEDY JOIST HANGERS

Standard Leg Speedy

Depth ≤ 225
W = 38 : L = 281 : X = 116
W = 44 : L = 278 : X = 113
W = 47 : L = 276 : X = 111
W = 50 : L = 275 : X = 110
W = 63 : L = 268 : X = 103
W = 75 : L = 262 : X = 97
W = 91 : L = 255 : X = 90
W = 100 : L = 250 : X = 85

Long Leg Speedy

Depth ≤ 225
W = 38 : L = 396 : X = 137
W = 47 : L = 392 : X = 134
W = 50 : L = 390 : X = 131
W = 63 : L = 383 : X = 124
W = 75 : L = 377 : X = 118
W = 91 : L = 370 : X = 111
W = 100 : L = 365 : X = 106

Speedy Girder Truss Shoe

W = 38 : L = 271 : X = 115
W = 44 : L = 268 : X = 112
W = 47 : L = 267 : X = 110
W = 50 : L = 265 : X = 109
W = 75 : L = 252 : X = 96

Girder / Girder Speedy

W = 80 : L = 550 : X = 490
W = 105 : L = 550 : X = 490
W = 120 : L = 550 : X = 490
W = 155 : L = 550 : X = 490

RESTRAINT STRAPS

BAT straps are manufactured in two types. Heavy Duty to provide horizontal restraint and Standard to provide vertical restraint against uplift forces.



Heavy Duty Restraint Strap



Standard Restraint Strap

Design Features

- The straps are manufactured from pre-galvanized steel strips to BS EN 10346 : 2015, S250GD + Z600 or stainless steel to BS EN 10088-1 : 2014 : 1.4301.

- Nominal Dimensions
Heavy Duty - 27.5 x 4mm
Standard - 27.5 x 2mm

Installation Requirements

Installation must comply with Building Regulations, P06697 and BS 8103 : Part 1, as well as NHBC recommendations.

If straps are fixed across joists or trussed rafters which are parallel with the wall, and there is a gap between the wall and the first joist or truss, the gap must be packed. Noggins must be used between each joist or truss.

Fixing for horizontal restraint:
5 no 4 x 75 round wire nails 1 per noggin, 1 per joist. Strap must cross 3 joists.

Fixing for vertical restraint:
Wallplate - 2 no 3.75 x 30 square twisted nails.
Blockwork - 4 no M5 x 50 wood- screws into nylon wall plugs, one of which within 150mm from the bottom. For stainless steel straps, stainless steel fixings must be used.

RESTRAINT STRAPS

Fixing Hole Layout

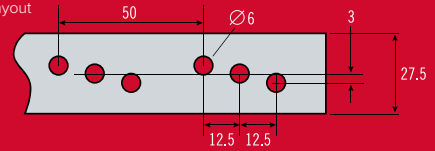

How to order

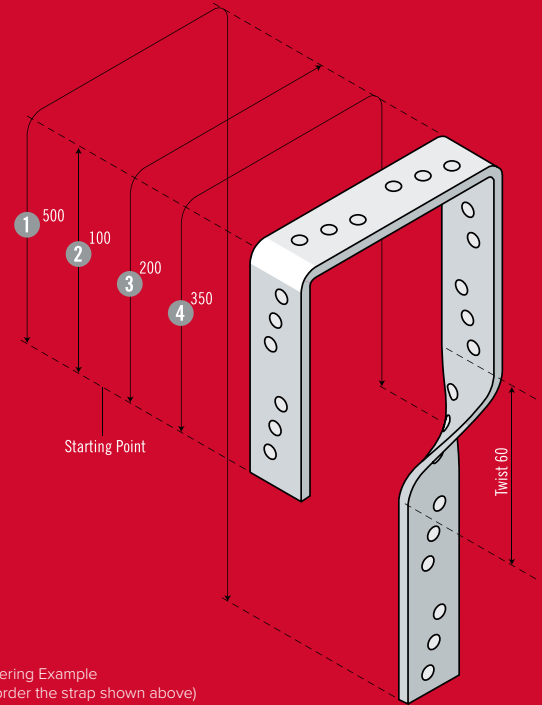

Ordering Example
(to order the strap shown above)

		1	2	3	4
	Strap Type	Total Strap Length 500	Bend at 100	Bend at 200	Twist at 350
Order Reference	HD	0500	B100	B200	T350
Options	ST Standard HD Heavy Duty	4 digits (mm)	S = Straight B = 90° Bend T = 90° Twist Distance from Start (mm)		

Twists are clockwise as shown above unless otherwise specified.

If in doubt, please provide a sketch of what is required,

HERRINGBONE JOIST STRUTS

Herringbone Joist Struts provide stability to floor joists and significantly reduce labour compared with timber strutting.

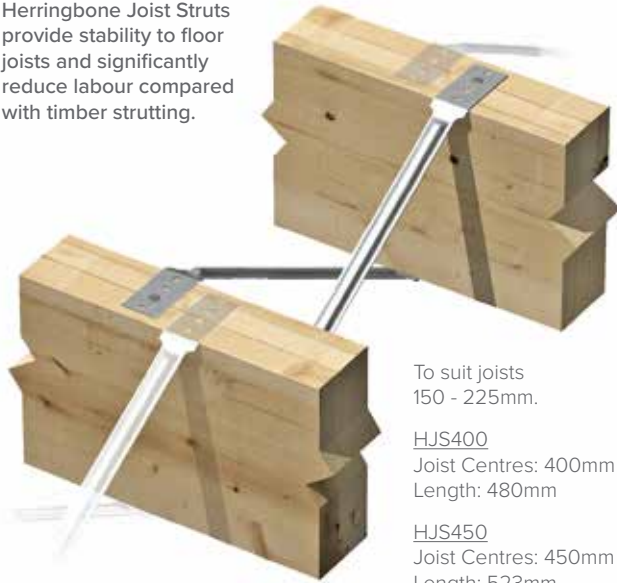

To suit joists
150 - 225mm.

HJS400
Joist Centres: 400mm
Length: 480mm

HJS450
Joist Centres: 450mm
Length: 523mm

HJS600
Joist Centres: 600mm
Length: 660mm

Specification:

Manufactured from 0.9mm thick pre-galvanized mild steel to BS EN 10346 : 2015, DX51D + Z275.

Hole diameter: 4mm
Qty per box: 50

Installation Requirements

Joist Span – 2.5m to 4.5m
1 Row at mid span

Greater than 4.5m
2 Rows at 1/3 span positions

Recommended fixing:
BAT 3.75 x 30mm long square twisted sherardised nails.



Fix with single 3.75 x 30mm sherardised square twisted nail per strut end



When fixing the second strut a 6mm (approx) gap should be kept between the struts.

TRUSS CLIPS

The Bat Truss Clip eliminates the disadvantages of skew nailing trussed rafters to timber wall plates: damaged connector plates, split rafters or wall plates.

TC38
for 38mm trusses

TC50
for 50mm trusses

Wider trussed rafters may be fixed using pairs of BAT Framing Anchors, types MFAAL and MFAAR as shown overleaf.

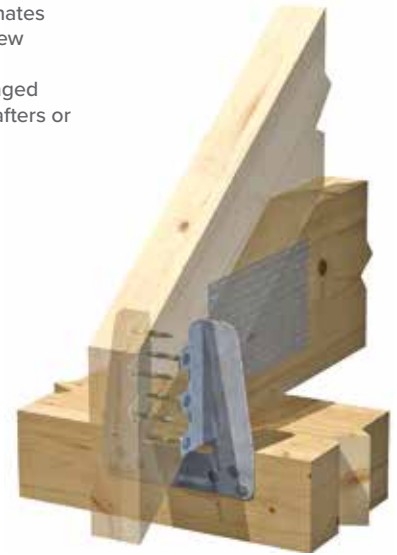

Specification:

Manufactured from 0.9mm thick pre-galvanized mild steel to BS EN 10346 : 2015, DX51D + Z275.

Overall height: 117mm
Overall width: 114mm
Hole diameter: 4mm
Qty per box: 200

Installation Requirements

Use BAT 3.75 x 30mm long square twisted sherardised nails.

All nail holes must be filled.

Characteristic load bearing capacity (Fk) :

Uplift - 38mm - 2.7 kN
Uplift - 50mm - 1.6 kN

The timber wall plate must be securely held down onto the supporting masonry.

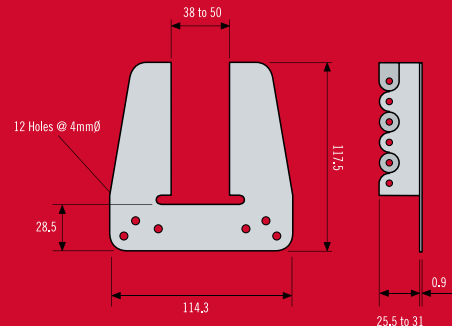

FRAMING ANCHORS

BAT Multi-Grip Framing Anchors offer the most effective and economical method of providing strong, mechanical joints for framing of timbers.

MFAAL & MFAAR for anchoring rafters and trusses to wall plate.

MFABL & MFABR for anchoring headers to studs, beams to posts and studs to plates.

MFAC for right or left handed use – for anchoring joists to beams, stringers to headers and hip joints.

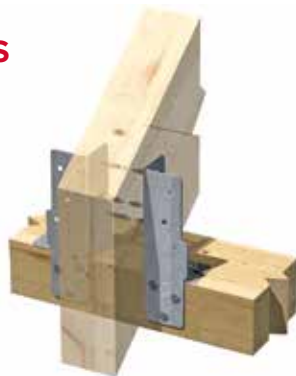

MFAAL / MFAAR
(left and right handed versions)



MFABL / MFABR
(left and right handed versions - MFABR shown)



MFAC

Specification:

Manufactured from 0.9 mm thick pre-galvanized mild steel to BS EN 10346 : 2015, DX51D + Z275.

Overall height: 127mm
Overall width: 38mm
Hole diameter: 3.8mm
Qty per box: 200

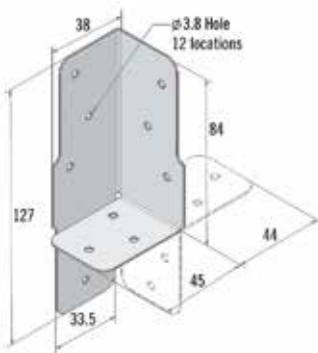

Installation Requirements

Always use in pairs to prevent eccentric loading.

Recommended fixing: BAT 3.75 x 30mm long square twisted sherardised nails.

Fixings should be used in all available timber facing holes.

ANGLE PLATES

BAT Angle Plates are used as a safe and economical method of connecting joists to purlins.

AP30030

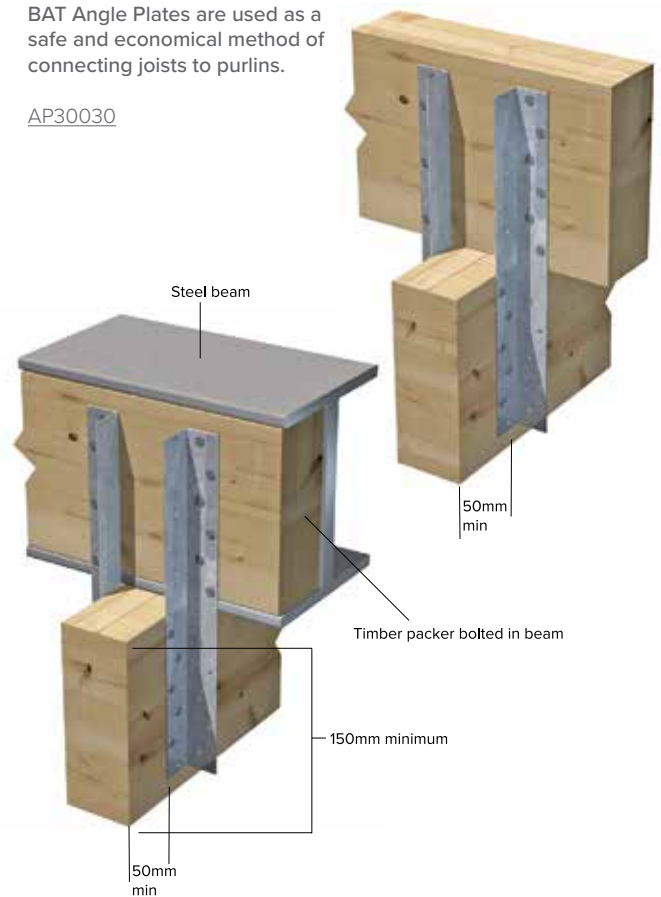

Specification:

Manufactured from 2mm thick hot dipped pre-galvanized mild steel to BS EN 10346 : 2015, DX51D + Z275.

Length: 300mm
Width each wing: 30mm
Hole diameter: 4mm
Qty per bag: 50

Characteristic load capacity F_k - C24 timber

1 pair - 6.8kN
2 pairs - 16.8kN

Installation Requirements

Fixing: use BAT 3.75 x 30mm long square twisted sherardised nails.

Fixings should be used in all timber facing nail holes.

Minimum timber depth of 150mm.

Ensure the timbers project a minimum of 50mm beyond the Angle Plates.

ANGLE BRACKETS

BAT Angle Brackets are designed for multi-purpose fixing applications and can be used as replacement cleats, nailed or bolted.

Design Features

- Manufactured from hot dipped pre-galvanized mild steel to BS EN 10346: 2015, S250GD + Z275.



Installation Requirements

Angle Brackets may be used for timber/timber, timber/steel and timber/masonry connections. Brackets may be fixed with screws, nails, bolts or coach screws. Must be used in pairs to prevent eccentric loading.

AB303015
CSK for screws
Max M3.5 x 4
Qty: 100



AB404040*
Ø5 x 8
Qty: 100

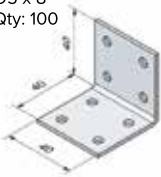

AB505035
Ø4 x 9
Qty: 100

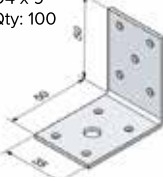

AB604060*
Ø4.5 x 12
Ø7 x 2
Ø11 x 1
11*30 x 1
Qty: 100

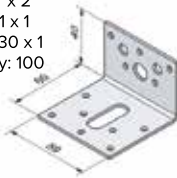

AB804042
Ø4 x 6
Ø7 x 2
11*30 x 1
Qty: 50

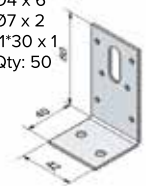

AB808018
CSK for screws
Max M4 x 4
Qty: 50

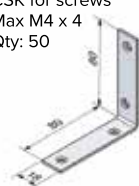

AB906059
Ø4 x 12
Ø9 x 4
11*30 x 1
Qty: 50

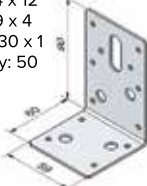

AB909060
Ø4 x 16
Ø9 x 4
Ø11 x 1
11*30 x 1
Qty: 50

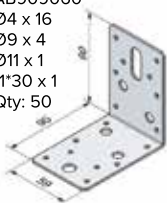

AB1006060*
Ø5 x 20
Ø11 x 3
Qty: 50

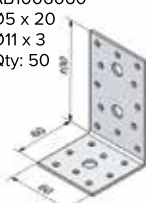

AB12512542
Ø4 x 16
Qty: 50

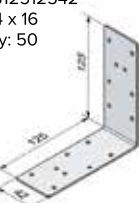

ANGLE BRACKETS

AB1509059
Ø4 x 21
Ø9 x 4
Ø11 x 1
11*30 x 2
Qty: 50

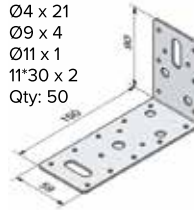

AB15015063
Ø4 x 20
Ø9 x 6
11*30 x 2
Qty: 50

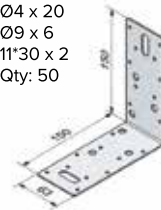

HD9090*
Ø4 x 16
Ø9 x 4
Ø11 x 1
11*30 x 1
Qty: 50

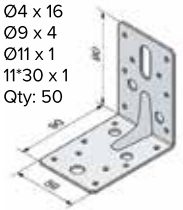

HD15090*
Ø4 x 21
Ø9 x 4
Ø11 x 1
11*30 x 2
Qty: 50

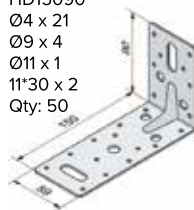

HD150150*
Ø4 x 20
Ø9 x 6
11*30 x 2
Qty: 40

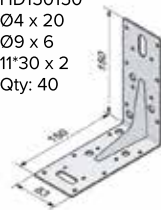

AAB1403540*
Ø5 x 15
Ø11 x 3
9*30 x 1
Qty: 50

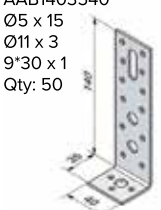

AAB806520
Ø6.5 x 2
6.2*52 x 1
Qty: 20
4mm thick

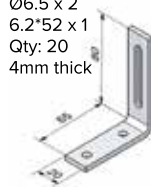

NPA767676
Use SN32 x 24 no
Qty: 50

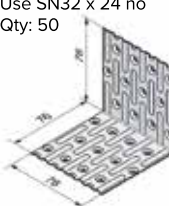

NPA575751
Use SN32 x 12 no
Qty: 50

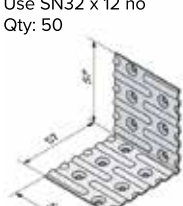

AP2103030
Ø4 x 22
Qty: 50



T1408030
CSK for screws
Max M4.5 x 6
Qty: 20

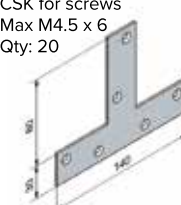

L12012020
CSK for screws
Max M3.5 x 5
Qty: 20



JP17559
Ø4 x 16
Ø9 x 4
Ø11 x 1
11*30 x 1
Qty: 50

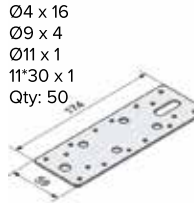

JP46250
Ø4 x 16
Qty: 50

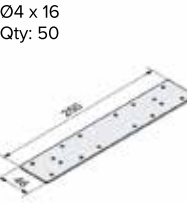

JP63300
Ø4 x 20
Ø9 x 6
11*30 x 2

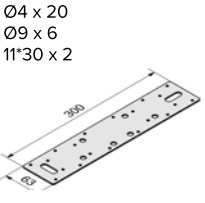

ANGLE BRACKETS

Characteristic load capacity of angle brackets F_k (kN)

Note: load values shown are per pair of brackets.

Brackets are not to be used individually in structural applications.

AB604060
3.75 x 30 square twisted nail (SN32)
12 x minimum in holes indicated to achieve loads

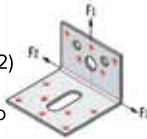

Load Condition	Load (C24 timber)
F1 Uplift	4.17
F2,3 Shear	5.69

AAB1403540
4 x 40 annular ring shank nail
13 x minimum in holes indicated to achieve loads

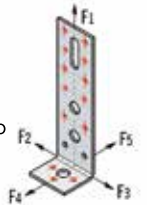

Load Condition	Load (C16 timber)
F1 Uplift	0.91
F2,3 Shear	3.27
F4,5 Shear	2.1

HD15090
3.75 x 30 square twisted nail (SN32)
21 x minimum in holes indicated to achieve loads

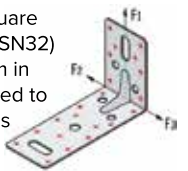

Load Condition	Load (C24 timber)
F1 Uplift	1.7
F2,3 Shear	6.07

AB404040
4 x 40 annular ring shank nail
6 x minimum in holes indicated to achieve loads

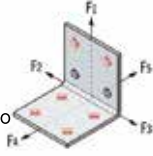

Load Condition	Load (C16 timber)
F1 Uplift	1.24
F2,3 Shear	3.52
F4,5 Shear	1.72

AB1006060
4 x 40 annular ring shank nail
15 x minimum in holes indicated to achieve loads

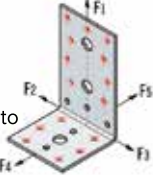

Load Condition	Load (C16 timber)
F1 Uplift	2.37
F2,3 Shear	7.93
F4,5 Shear	3.55

HD9090
3.75 x 30 square twisted nail (SN32)
16 x minimum in holes indicated to achieve loads

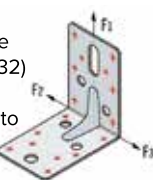

Load Condition	Load (C24 timber)
F1 Uplift	2.79
F2,3 Shear	4.6

HD150150
3.75 x 30 square twisted nail (SN32)
20 x minimum in holes indicated to achieve loads

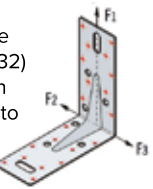

Load Condition	Load (C24 timber)
F1 Uplift	1.67
F2,3 Shear	6.07

TIMBER CONNECTORS

BAT Timber Connectors are compliant with **BS EN 912:2000** 'specification for connectors for timber'. Safe working loads, end distances and spacing are all set out in **BS 5268 Part 2**.

Shear Plate
SPT67 (B2) x 150 per box
SPT102 (B3) x 50 per box
Designed for use with M20 bolt.
67mm – Galvanized hot rolled steel to BS EN 10025.
100mm – Galvanized cast iron to BS EN 1562.

Square Plate Washers
SPW50 (50mm square).
To suit 12mm bolt. 250 per box.

Tooth Plate (Round)
50, 63 and 75 diameter.
200, 150 and 100 per box respectively.
Available in both single and double sided, eg. ref.TCSSS (C6); TCDS (C7) etc.
Suitable for M12 bolt.
Pre-galvanized steel to BS EN 10346 : 2015
DX51D + Z275.

Split Ring
SRTC64 (A3) x 100 per box
SRTC102 (A3) x 100 per box
Designed for use with M12 and M20 bolts respectively.
Double bevelled.

Manufactured from galvanized hot rolled steel to BSEN10025.



Shear Plate 67



Shear Plate 102



Tooth Plate (Round)



Split Ring

Application Tools for use with timber connectors. Available to special order.

Reference	Type	Size
SRGT/64	Split Ring Grooving & Dapping Tool	64mm split ring
SRGT/102	Split Ring Grooving & Dapping Tool	102mm split ring
DT/67	Shear Plate Grooving & Dapping Tool	67mm shear plate
DT/102	Shear Plate Grooving & Dapping Tool	102mm plates

SPLICE PLATES

- Minimum timber thickness 50mm.
- All fixing nails included.
- 8 sets of 4 per box. (L61/L80)
- 4 sets of 4 per box. (L98)

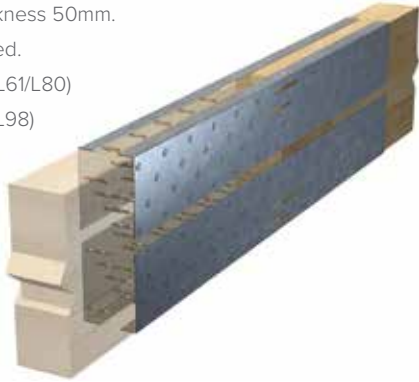

Reference	Size (mm)	Joist Depth (mm)	SLS Resistance Moment (kN)	SLS Shear Capacity (kN)	Aprox. Nails Per Plate
L61	18 x 61 x 400	125/150	1.5	13	27
L80	18 x 80 x 560	175/200	1.5	13	52
L98	18 x 98 x 560	225/250	1.5	13	65

FRAME CRAMP

To provide positive location and support of window from timber framing to resist wind and incidental loadings.

Design Features

- Manufactured from 0.9mm thick hot dipped galvanized mild steel to BS EN 10346 : 2015 DX51D + Z275.

- Box quantity 100



Installation Requirements

Fixing: use BAT 3.75 x 30mm long square twisted sheradised nails.

Ref.	Width	Length	Upstand
FC1	76mm	202mm	
FC2	76mm	212mm	40mm

BAT-U-NAIL PLATE

BAT-U-Nail is a plate system which enables timber structures to be made on site or in the builders workshop, since it is nailed by hand.

Design Features

- Manufactured from 0.9mm pre-galvanized mild steel to BS EN 10346: 2015 : DX51D + Z275.
- Widths: 76, 114 and 152mm
- Lengths: 51, 100, 152, 203, 254, 305 and 354mm.
- Various quantities per box. Ref. eg. BP7651.



Installation Requirements

BAT-U-Nail plates are to be fixed on both sides of the timber. Fixing: use BAT 3.75 x 30mm long square twisted sheradised nails. Loading in the direction of the plate stiffening ribs.

345 N/nail (parallel to timber grain).
145 N/nail (perpendicular to timber grain).

Plate compression value 40 N/mm width of plate. To calculate capacity of connections, the lesser of anchorage, plate compression and tension should be taken.

Fix in accordance with BS 5268 : Part 2.

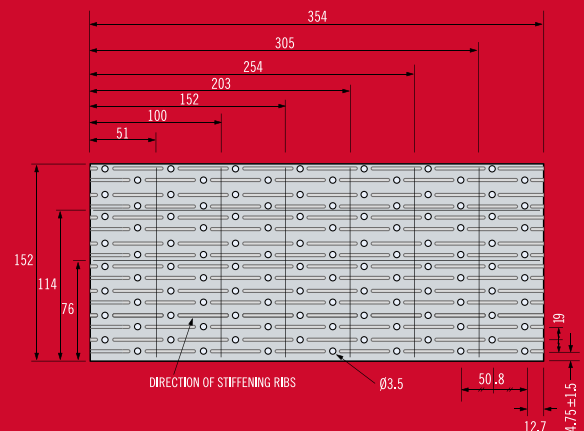

MULTI-PURPOSE FIXING BANDS

Expamet Fixing Band is an easy-to-use coil strip designed for all types of light fixing applications.

Design Features

- Manufactured from hot dipped galvanized mild steel to BS EN 10346 : 2015 DX51D + Z275.
- Stainless steel (MFBASS)



Installation Requirements

Fixing: use BAT 3.75 x 30mm long square twisted sherardised nails, screws or bolts. Not to be used below ground.

Ref.	Width	Thickness	Length
MFBA	20mm	0.9mm	10m
MFBB	20mm	0.7mm	10m
MFBASS	20mm	0.9mm	10m

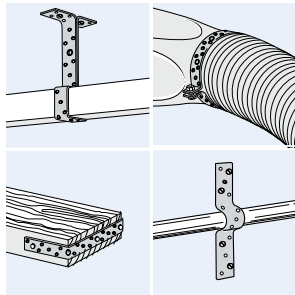

JUNCTION CLIP

Can be used instead of noggins, at wall junctions and at contact points between ceiling and walls when fitted at 300mm centres.

Design Features

- Manufactured from 0.9mm hot dipped galvanized mild steel to BS EN 10346 : 2015 : DX51D + Z275. Ref. JC1 250 per box.



Installation Requirements

Fixing: use BAT 3.75 x 30mm long square twisted sherardised nails or ordinary plasterboard nails.

SOLE PLATE ANGLES

BAT Sole Plate Angles positively locate timber sole plates to concrete floor slabs using masonry fixings as required, without penetrating the dpc.



Design Features

- Manufactured from 0.9mm thick hot dipped galvanized mild steel to BS EN 10346 : 2015 DX51D + Z275.
- Box quantity 100

Installation Requirements

BAT Sole Plate Angles may be fixed on the inside of the sole plate or alternatively fixed under the sole plate with the upstand on the outside of the sole plate.

Fixing: use 3.75 x 50mm min. length nails/masonry nails.

Ref.	Width	Length	Upstand
SPA112	76mm	112mm	40mm
SPA162	76mm	162mm	40mm

SAFE PLATE

For protection of plumbing and electrical wiring against random nailing into studs.

SAF1
90 x 54mm

Design Features

- Manufactured from 0.9mm hot dipped galvanized mild steel to BS EN 10346 : 2015 : DX51D + Z275.

- 200 per box

Installation Requirements

Use wherever services occur within 75mm of face of plasterboard or 100mm of surface of floor deck.
Fixing: Tap in with hammer.

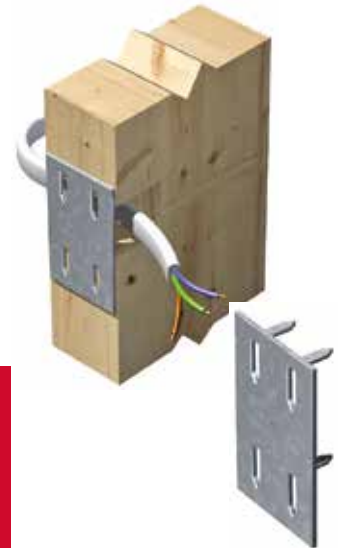

STAINLESS STEEL WALL TIES

Expamet wall ties are compliant with BS EN 845 –1 the specification for ancillary components for masonry, Part 1: ties, tension straps, hangers and brackets.

Wall ties should be installed in accordance with PD6697, recommendations for the design of masonry structures to BS EN 1996-1-1 and BS EN 1996-2.

Stainless steel type 1.4301 to BS EN 10088-1.

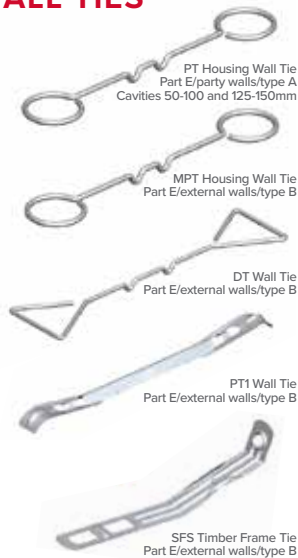

SSCD Insulation Retaining Disc



Code	Nominal Cavity Width (mm)	Qty	Type	Description
PT200#50	75	5 x 50	Type 4	200mm Housing Wall Tie
PT200	75	250	Type 4	200mm Housing Wall Tie
PT225#50	100	5 x 50	Type 4	225mm Housing Wall Tie
PT225	100	250	Type 4	225mm Housing Wall Tie
PT250	125	250	Type 4	250mm Housing Wall Tie
PT275	150	250	Type 4	250mm Housing Wall Tie
MPT200#50	75	5 x 50	Type 2	200mm General Purpose Wall Tie
MPT200	75	250	Type 2	200mm General Purpose Wall Tie
MPT225#50	100	5 x 50	Type 2	225mm General Purpose Wall Tie
MPT225	100	250	Type 2	225mm General Purpose Wall Tie
MPT250	125	250	Type 2	250mm General Purpose Wall Tie
PT1-200	75	250	Type 1	200mm Heavy Duty Wall Tie
PT1-225	100	250	Type 1	225mm Heavy Duty Wall Tie
PT1-250	125	250	Type 1	250mm Heavy Duty Wall Tie
PT1-275	150	250	Type 1	275mm Heavy Duty Wall Tie
PT1-300	150	250	Type 1	300mm Heavy Duty Wall Tie
DT200	75	250	Type 2	200mm Double Triangle Wall Tie
DT225	100	250	Type 2	225mm Double Triangle Wall Tie
DT250	125	250	Type 3	250mm Double Triangle Wall Tie
DT300	150	250	Type 3	300mm Double Triangle Wall Tie
SSCD		250		Insulation Retaining Disc. Fits all Ties
SSFS50	50	250	Type 6	Timber Frame Tie including nail
SSFS75	75	250	Type 6	Timber Frame Tie including nail
SSFS100	100	250	Type 6	Timber Frame Tie including nail

STAINLESS STEEL SCREW-IN STARTER AND CAVITY TIES

A quick and easy way to tie new walls to existing walls.

Screw-in starter and cavity ties are made from austenitic stainless steel to BS EN 10088-3.

Nominal cavity width for SCT: 50 - 100mm.

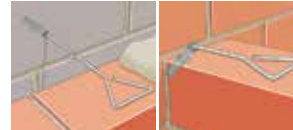

Supplied with masonry plug.

Code	Length (mm)	Qty	Description
SST130#10	130	10	Screw-in starter tie
SST130	130	100	Screw-in starter tie
SCT150	150	100	Screw-in cavity tie with V drip
SCT180	180	100	Screw-in cavity tie with V drip
SCT200	200	100	Screw-in cavity tie with V drip
SCT225	225	100	Screw-in cavity tie with V drip

STAINLESS STEEL SCREW-IN FRAME TIE

Screw-in frame ties secure timber window and door frames to inner leaf of masonry.



Code	Length (mm)	Qty	Material
SIFT130RT	130	100	Stainless Steel
SIFT130#10	130	10 bags of 10	Stainless Steel

FRAME CRAMPS

A comprehensive range of stainless steel frame cramps with safety end or plain end options for fixing to concrete, steel and masonry.

V-drip and vertical twists are offered as options and drips can be offset to accommodate insulation materials.

Compliant with BS EN 845-1



SEPE SESE SESE (V) PEFC (H) SEFC (H) SEFC (HC)



PEFC (S) SEFC (S) SEFC (SV) Debonding and isolation sleeves

Code	Lengths available (mm)	Upstand	Description
SEPE...	150/200/225/250	n/a	Movement tie
SESE...	150/200/225/250/300	n/a	Double safety end fixing
SESE...V	150/200/225/250/300	n/a	Dbl sfty end with 'V' drip
PEFC...30H	100/125/150	30	Plain end frame cramp
SEFC...30H	75/ 100/125/150/175/200	30	Frame cramp
SEFC...30HV	125/150/200/300	30	Frame cramp with 'V' drip
PEFC...50S	100/125/150	50	Plain end frame cramp
SEFC...50S	75/150/200/300	50	Frame cramp
SEFC...50SV	125/150/200/300	50	Frame cramp with 'V' drip
20022	100*	n/a	Debonding sleeve

* Other sizes available - please call for more information

SECURITY MESH

A cost effective way of securing buildings or internal spaces by sandwiching a layer of steel mesh into the walls and ceilings during construction.

Available in a range of gauges this high quality security mesh is suitable for internal walls, ceilings, partitions and external brickwork. It can also be provided in galvanized steel, where damp conditions are expected.

See our full range of expanded metal and lath at

www.expamet.co.uk



50-73HFG / 50-73HF

50-89HRG / 50-89HR

50-76MFG / 50-76MF

Ref.	Security Mesh Type	Mesh LW	Mesh SW	Strand Width	Strand Thickness	Weight Kg/m ²	Sheet Size
50-73HFG	Flattened Galvanized Mild Steel	42.9	14.2	4.6	2.7	8.59	2440 x 1220
50-89HRG	Raised Galvanized Mild Steel	50.8	22.6	3.1	3.0	6.52	2440 x 1220
50-76MFG	Flattened Galvanized Mild Steel	43.4	18.0	2.3	1.1	1.85	1250 x 2440
50-73HF	Flattened Mild Steel	42.9	14.2	4.6	2.7	8.59	2440 x 1220
50-89HR	Raised Mild Steel	50.8*	22.6*	3.1	3.0	6.52	2440 x 1200
50-76MF	Flattened Mild Steel	43.4	18.0	2.3	1.1	1.85	1250 x 2440

* Mesh pitch size

EXMET REINFORCEMENT

Stainless steel Exmet is manufactured from austenitic stainless steel 1.4301 to BS EN 10088-1.

Coil length: 20m.

Expanded steel mesh with no joints or interweaving to fail under stress.

For non-structural applications.

Overlap ends: 75mm.

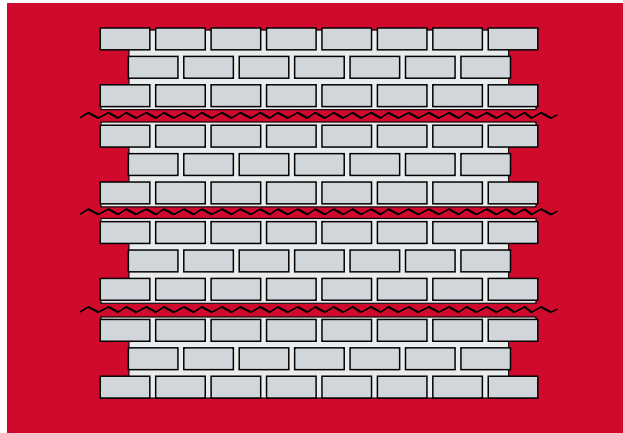

Ref.	Material Thickness (mm)	Coil Size Width (mm)	Wall Width (mm)	Quantity
76820	0.3	65	100	5
76920	0.3	115	140	5
77020	0.3	175	225	1
77120	0.3	225	265	1

FLAT WIRE REINFORCEMENT

Flat Wire Ladder Reinforcement is made from austenitic stainless steel to 1.4301 : BS EN 10088-3. Ladder length 2700mm.

Type: single leaf.
Conforms to BS 5628-2 and BS 845-3. 500N/mm² minimum tensile strength.

Special designs are available on request for corners and T-shapes.

Overlap ends 225mm.



Ref.	Main Wire Height (mm)	Equivalent Round Wire Diameter (mm)	Ladder Width (mm)	Wall Width (mm)	Qty
SBSF3060	2.8	3	60	100	20
SBSF30100	2.8	3	100	140/150	20
SBSF30150	2.8	3	150	190/200	20
SBSF30175	2.8	3	175	215	20
SBSF3560	2.9	3.5	60	100	20
SBSF35100	2.9	3.5	100	140/150	20
SBSF35150	2.9	3.5	150	190/200	20
SBSF35175	2.9	3.5	175	215	20
SBSF4060	3	4	60	100	20
SBSF40100	3	4	100	140/150	20
SBSF40150	3	4	150	190/200	20
SBSF40175	3	4	175	215	20
SBSF4560	3	4.5	60	100	20
SBSF45100	3	4.5	100	140/150	20
SBSF45150	3	4.5	150	190/200	20
SBSF45175	3	4.5	175	215	20
SBSF5060	3	5.0	60	100	20
SBSF50100	3	5.0	100	140/150	20
SBSF50150	3	5.0	150	190/200	20
SBSF50175	3	5.0	175	215	20

WALL STARTERS & MULTI-STARTERS

The quick, easy-to-fix way to tie-in new walls to existing walls without cutting out brickwork. Suitable for walls of up to 3 storeys high, i.e. up to 8m maximum.

Wall Starters

Individual flanged products designed for specific widths of new walls.

Multi-Starters

Featuring a 'turn-n-slide tie' to accommodate all sizes of brick or block.

The Multi-Starter is suitable for all wall widths from 60mm-250mm.



Wall Starters



Multi-Starters

Ref.	Description	Type	Wall Thickness
Wall Starters			
WS060	Stainless Steel	Single Flange Integral Tie	60-75mm
WS090	Stainless Steel	Single Flange Integral Tie	100-115mm
WS120	Stainless Steel	Single Flange Integral Tie	125-180mm
WS185	Stainless Steel	Single Flange Integral Tie	190-260mm
WGC060	Plastisol Coated Galv	Single Flange Integral Tie	60-75mm
WGC090	Plastisol Coated Galv	Single Flange Integral Tie	100-115mm
WGC120	Plastisol Coated Galv	Single Flange Integral Tie	125-180mm
WGC185	Plastisol Coated Galv	Single Flange Integral Tie	190-260mm
Multi-Starters			
MSSS/12	Stainless Steel	No Flange Turn-n-slide Ties	Up to 250mm
MSGC/12	Plastisol Coated Galv	No Flange Turn-n-slide Ties	Up to 250mm
MSGFIX	Plastisol Coated Galv	Extra Fixing Pack	
MSSFIX	Stainless Steel	Extra Fixing Pack	

ACCESSORIES

Scrolled Hip Irons

Designed to provide decorative restraint when bedding hip tiles.



Ref.	Material	Length x Width x Thick	Height
HIP2003	Galvanized Steel	200mm x 25mm x 3mm	100mm
HIP2503	Galvanized Steel	250mm x 25mm x 3mm	150mm
HIP3003	Galvanized Steel	300mm x 25mm x 3mm	150mm
HIP3004	Galvanized Steel	300mm x 25mm x 4mm	150mm

Gallows Bracket

The Gallows Bracket provides a method of supporting otherwise unsupported brickwork.

Manufactured from 50 x 50 x 5 angle, red oxide finish.

Two sizes are available (supplied in pairs).

To suit M12 Masonry Anchors - not supplied.

MH375375
375mm high x 375mm deep
(projection from wall)

MH490375
490mm high x 375mm deep
(projection from wall)

Stainless Steel Annular Ring Nails

SSRN 3.35 x 50mm
1000 per box

Sherardised Nails
SN32 BAT 3.75 x 30mm twisted
1000 per box



Expamet is one of the leading brands of specialist building products in the UK, Europe and the Middle East. Operating across two continents, we offer internationally recognisable products that are synonymous with quality, safety and innovation. Wherever you are and whatever your project, Expamet solutions are never far away.

EXTENSIVE PRODUCT RANGE

Each of our great brands is committed to quality in its particular product field.

- **BAT** – Builders' metalwork products
 - **Expamet** – Plasterers' accessories
 - **Hy-Rib®** – Permanent formwork for concrete
-

TECHNICAL AND SALES SUPPORT

Our comprehensive technical support service is designed to support your project all the way from specification to completion. Our expert technical and sales teams have extensive experience in the construction and engineering industries and are always on hand to offer advice on using our products to their full potential. Call us today on 0845 121 2260 to find out more.



Greatham Street, Longhill Industrial Estate (North)
Hartlepool TS25 1PU United Kingdom
Tel: Sales: 0845 121 2260
E-mail: expamet.sales@birtleygroup.co.uk
Website: www.expamet.co.uk

Quality assurance BS EN ISO 9001 and ISO 14001 2004 Registered Firms Certificate No. FM589272, EMS 589274



All products within the scope of regulation No. 305/2011 'The Construction Products Regulation' are CE marked in accordance with all relevant Harmonised Standards and ETA's. Declaration of performance documents can be found at www.expamet.co.uk

Birtley Group operate a continuous development programme and reserve the right to amend specification without prior notification. Please note some products are not manufactured by Birtley Group and are therefore excluded from our registration to BS EN 9001: 2008. Please contact the technical department for further information.

All copyright, trade marks and unregistered design rights for the products detailed in this brochure are the property of Birtley Group Ltd.
