



The **world's** first antimicrobial PVC wall cladding containing BioCote® technology



*Installation, Maintenance and Architectural Detailing Guide
June 2011*

Table of Contents

Section 1 - Product Overview

Section 2 - Typical Applications

Section 3 - Limitations

Section 4 - Tools and Equipment

- 4.1 Installation Tools List
- 4.2 BioClad Thermoformer™
- 4.3 Using the BioClad Thermoformer™
- 4.4 Measuring for Bends in the BioClad Panel

Section 5- Adhesives

Section 6- Preparation/Pre-installation

- 6.1 Environment
- 6.2 Wall Substrates
- 6.3 Preparation/Pre-installation instructions

Section 7 - Installation

- 7.1 Jointing Methods Overview
- 7.2 Two-part Joint Strip Installation Procedure
- 7.3 Single-part Joint Strip Installation Procedure
- 7.4 Heat Welding Installation
- 7.5 Wall to Floor Transition Strip

Section 8 - Cleaning

Section 9 - Safety Procedures

Section 10 - Datasheets



Section 1 - Product Overview

BioClad is a semi-rigid, smooth, and durable vinyl sheet panel system. The material is thermoplastic and can be cut and thermoformed into specific shapes to suit the contours of the building. Its semi-rigid properties allow BioClad to be installed over most sound substrates with minimal preparation and disruption.

All joint, transition, and edge trims are high quality vinyl co-extrusions incorporating a neoprene gasket for a watertight surface. When incorporated with heat-welded, flash coved flooring, the system is ideal for such areas as showers, clean rooms, and laboratories.

For detailed specifications contact BioClad Ltd.

BioClad Product Specifications

Advanced BioClad® Single Skin PVC Panel

- Manufacturer: Advanced Hygienic Contracting Ltd.
 - Web: www.cladding.co.uk
 - Tel: 0330 100 0313
 - Product reference: Advanced BioClad® Single Skin PVC Panel

- Size (w x h): [1220 x 2500 mm]
[1220 x 2800 mm]
[1220 x 3050 mm]

- Thickness: [2.5 mm] Manufacturer's Standard

Advanced BioClad® PVC Antimicrobial Panel containing Biocote silver Ion antimicrobial additive throughout the product thickness with a lifetime guarantee and a Single source Manufacture/installer warranty

Fire rating to BS 476-7:1971: Class 1.

Section 2 - Typical Applications

- Showers
- Kitchens
- Operating Rooms
- Scrub Rooms
- Laboratories
- Clean Rooms
- Veterinary Clinics
- Food Production Areas
- Service Corridors

Limitations

Semi-rigid panels can be applied to most surfaces, it should however, not be installed near a heat source such as steam kettles, pizza ovens, cooking ranges, steam rooms, etc, or where exposed flame or severe heat could cause distortion of the BioClad panel.

- Once installed, BioClad panels should not be exposed to temperatures above 140° F (60° C). BioClad can become brittle at low temperatures and is not recommended for installations subject to temperatures below 23° F (-5° C) where it is exposed to high impact. It is fine in chill rooms and refrigerated storage but is not recommended for freezers.
- Before the testing of kitchen equipment, which is likely to expel severe heat, extraction systems must be operational. Failure to do so may result in expansion problems.



Section 4 -Tools and Equipment

4.1 - Installation Tools List

Below are tools that you may need for the installation of BioClad:

Hand Tools:

- Stanley knife and blades
- Kirsten scraper (decorators scrapping tool/paint scraper)
- square notch trowel
- wall roller
- hand roller
- 31 (1 meter) & 6' (2 meter) levels
- laser/water level
- ladders and/or scaffolds
- chalk line
- small block plane
- tape measure
- hammer
- rubber mallet
- caulking gun
- file
- hole cutters / drill bits
- anti-static wipes

Workbench:

- 1 piece of plywood (minimum 1/2" thick)
- 10' (3 meter) straight edge, if desired
- 2" x 4" or 2" x 6" support beams
- metal stands for Thermoformer
- 2 sets of legs (saw horses) working height of 34" (85cm)

Safety Equipment:

- goggles/safety glasses
- protective gloves
- hard hat
- safety boots
- visual vest

Electrical Equipment:

- access to electricity
- jigsaw with fine toothed blades
- electric sheet metal shears, if desired
- drill (for mixing paddle and hole saw)
- extension cords
- ProTek Whiterock Thermoformer™

4.2 - BioClad Thermoformer™

The BioClad Thermoformer allows installers to heat and shape BioClad wall panels to conform to the contours of a room. This allows the BioClad wall panels to remain seamless even around corners.

If using the BioClad Thermoformer, work should be done on an appropriate sized workbench. Supports should be recessed allowing the Thermoformer to be set into and ensuring that the heater top (Thermoformer) is level with the top of the bench. The bench top should be flush with the sides of the Thermoformer, and not covering it. This is so the panel can be laid across the heat source while thermoforming and an even distribution of heat is obtained along the length of the bend line.

Alternatively you may set up a 4x8 workbench on saw horses and set the Thermoformer adjacent on separate metal stands.

4.3 - Using the BioClad Thermoformer™

1. Assemble workbench with Thermoformer inset flush with the workbench.
2. Plug-in the Thermoformer and let it warm up for approximately 30 minutes before beginning thermoforming.
3. With pre-established bend lines marked on the face of the BioClad panel (blue side): centre the bend lines over the heat element opening on the Thermoformer heating from the backside when allowable. You may heat the face of the BioClad (blue side) for certain bends being careful not to melt the plastic film onto the service.
4. Allow sufficient time for the BioClad panel to heat up until there is a visible softening of the material over the line where the material is to be thermoformed (this takes approximately 30 seconds).
5. Immediately move the material from the Thermoformer onto the flat workbench.

6. Thermoforming can be done in one of two ways:

- Process one, used for sharper corner edges is accomplished by folding the material back upon itself and then returning to the position of the corner required and holding in place until the sheet has cooled and become rigid for approximately 30 seconds.
- Process two, used for softer corner edges, is accomplished by folding the material directly to the required corner angle and holding until cool and rigid for approximately 30 seconds.

7. Make any additional bends needed in the material following the same procedure.



4.4 - Measuring for Bends in the BioClad Panels

BioClad recommend; using thermoformed internal/external corner detail when installing the BioClad panels. This is achieved by heating the panel on a BioClad Thermoformer unit and manually forming the panel to the desired angle.

Always measure and mark on the face of the panels. Always measure from the outside of the previous corner.

First, exactly measure the substrate (distance) to be covered. Then either:

External to external corners, add the thickness of the panel and adhesive for both corners.

Internal to internal corners, subtract the thickness of the panel and adhesive for both corners.

Internal to external corners, use the exact measurement of the substrate, do not add or subtract.

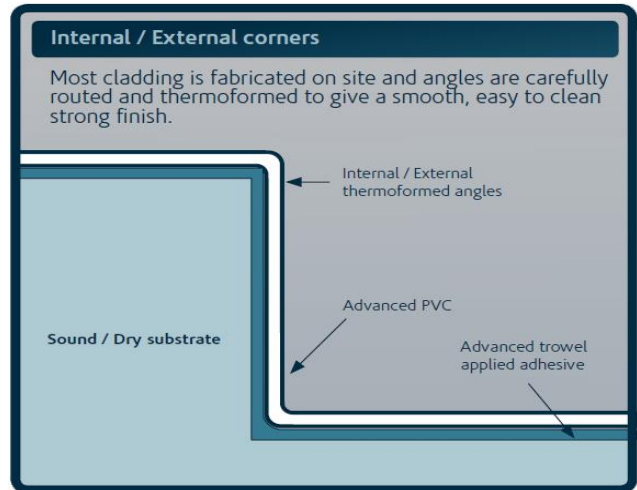

Section 5 – Adhesives

Use only approved adhesives as recommended by BioClad or its distributors. Consult the adhesive label for detailed application instructions.

Recommended Trowel Notch: Use a square notch trowel

Advanced 2 Part Adhesive: Two-part polyurethane adhesive is the default adhesive For Smooth Surfaces for most installations. This includes wet areas, non-climate controlled areas and "all" non-absorbent surfaces.

Water-based acrylic adhesive may be suitable for absorbent surfaces in dry, climate controlled areas

Bond test should be performed on all surfaces.

Substrate:

- Sheetrock
- Plywood
- Metal
- Ceramic tiles – *Provided tiles are firmly bonded to the substrate and free from surface contamination, grease etc.*
- Plaster
- Concrete
- Brickwork – *Brickwork & blockwork should be good quality and joints should be flush*
- Blockwork – *Brickwork and blockwork should be good quality and joints should be flush*
- Painted – *A bond test is advisable to check adhesive does not react with paint.*

Section 6 - Preparation and Pre-installation

6.1 – Environment

BioClad should be installed in an area with ambient temperatures between 65°F (18°C) and 80°F (27°C). Areas to receive BIOCLAD must be weather-tight and of approximate humidity conditions of the finished room.

6.2 - Wall Substrates

BioClad semi-rigid panels can be applied to most solid wall surfaces. All surfaces must meet these requirements:

- Walls should be smooth and level. High points must be removed and low points filled with filler intended for the substrate and environmental conditions.
- Wall tiles must be fixed firmly to the wall. As long as the tile edges do not protrude you do not have to skim grout joints.
- Surfaces must be permanently dry and free from all substances that may contribute to adhesive bond failure.
- Remove loose paint and conduct an adhesive bond test with paint.
- Exterior walls must be adequately dampproofed and insulated.
- Dry wall substrates should be paint ready.

6.3 - Preparation/Pre-installation Instructions

All surfaces must be free from dust and cleaned prior to BioClad installation. The working environment must also be dust free. Failure to comply with these conditions will reduce the bond strength between the adhesive and substrate, and may cause the BioClad panels to debond.

- Very absorbent / porous substrates (particularly plaster finishes and unprimed sheetrock) must have a proprietary sealer e.g. PVA primer or similar, applied to the surface a minimum of 12 hours prior to the installation.

- All electrical switches, power points etc., should be in a first fix / installation state. All electrical equipment should only be moved or altered by a qualified electrician.
- All plumbing should have pipe-work removed to a first fix or installation state and "tails" left protruding from the substrate. BioClad panels can then be drilled and slid over the pipe tails. All holes should be drilled 1/8" (3mm) oversize to allow for expansion, then sealed with Mastic caulking. Plumbing should always be done by a qualified plumber.
- Hot pipes and steam pipes should be insulated and a 1/8" to 1/4" (3-6mm) expansion gap should be created when installing panels around these pipes, then sealed with caulking.
- All pipes, fixing bolts, etc. extending through the BioClad panels should have a minimum (3mm) expansion gap and be sealed using caulking.
- If fitting to door frames, these must be in place prior to the installation of BioClad
- Prior to installation, it is advisable to complete any painting which comes in contact with BioClad. as sealant used at junctions is non-paintable.
- Panels should be stored flat and be pre conditioned a minimum of 24 hours in ambient temperatures similar to the prevailing operational conditions.
- The panels must be stored on a level flat surface off the ground (risk of condensation on the panels if stored on damp surfaces). Storage on uneven surfaces could cause the panels to distort prior to installation.
- First, check the room using a 6' (2 m) level to ensure all walls are flat, paying particular attention to the corners, window reveals, and door entrances. These need to be inspected to ensure they are free of any debris or irregularities, which could prevent the panels laying flat to the substrate after the adhesive has been applied and the panel installed.
- The wall surface must be clean and dust free prior to installation.

Section 7 – Installation

1. Apply a datum line (level line) around the entire installation area. The datum line is used for the calculation of measurements to ceiling/floor height, sockets, pipes, etc., and to ensure the panels are plumb as the installation proceeds. It is advisable to set this datum line at 51 (1550 mm) off the finished floor. This way the line is near eye level and is easy to locate when placing the panels on the wall.
2. Place panel on the workbench and inspect for damage. On the face (blue protective film), carefully mark your datum line on the blue paper, using a pen. taking care not to press too hard, and possibly damaging the surface of the BioClad panel.
3. Take measurements from the wall datum line to the floor/cove junction and to the ceiling, and then transfer these to the protective film of the panel. Cut the panel using a jigsaw with a fine toothed blade, making sure the panel is well supported to reduce any risk of stress in the material when being cut.
4. Once cut. peel back and remove the protective film approximately 2" (50mm) from the edge.
5. Hold the panel up to the substrate, ensuring you have a 1/8" (3mm) expansion joint at all abutments and pipe work.
6. Return panel to the workbench and make any bends as needed using the BioClad Thermoformer (see Section 4.2 ProTek Whiterock Thermoformer and Section 4.3 Using the Bioclad Thermoformer)
7. When the panel has been made to suit the required finish detail lay the panel face-down on the workbench and clean the back of the panel.
8. Apply the double-sided tape at the top, middle and bottom of the panel per the double-sided tape layout diagram (see Datasheet 14 of the datasheets in the back of this guide). (DO NOT remove the tapes' protective film at this time).

Adhesive Recommendations:

Advanced two-part polyurethane adhesive is recommended for all installations in wet areas, non-climate controlled areas and for "all" non-absorbent surfaces.

9. Prepare and spread the adhesive:

- When using Advanced two-part polyurethane adhesive, carefully mix parts A and B together using a low-speed mixing drill and paddle for a minimum of 3 minutes, until an even colour of the adhesive is acquired.

- Apply the adhesive to the back of the panel, using the recommended trowel notch size. The adhesive should be applied approximately (12mm) from the edge of the panel, and right up to the tapes.

- The working time of the adhesive is approximately 40 minutes depending on the ambient temperature of the room. The trowel must be held so that the adhesive is applied to an even finish, and the trowel notches are replicated to the same depth over the entire panel.

- At any points where there may be a gap between the wall and panel, apply additional adhesive.

10. Carefully remove the protective film from the double-sided tape, lift the panel to the wall and adhere to the required location using the datum line previously applied to the wall. Apply pressure to the datum line area of the panel so as to set the double-sided tape. Apply pressure to the whole panel face to ensure the adhesive has been transferred and will be fully bonded to the substrate. This is normally done with a wall roller or rubber mallet, and a piece of scrap material to prevent the surface from being damaged.

11. Failure to ensure a good transfer of adhesive to the substrate could result in the panel debonding.

12. The curing time of the adhesive is approximately 8-12 hours depending on the ambient temperature.

7.1 - Jointing Methods Overview

There are three types of jointing methods used with BioClad.

Joint Strips

Joint strips should be used in areas where there are temperature changes such as kitchens, showers, and spa areas. The joint strip gives the wall panel room to expand and contract due to the temperature and humidity changes.

There are two types of joint strips - a one part strip and a two part strip.

Single-part joint strips should be used in areas with public access or controlled areas such as prisons or mental health institutions where people could scratch or peel off the strips. Two-part joint strips are recommended for all other installations.

Heat Weld

Heat weld in environments where hygiene is critical to the application and a seamless flat wall surface is required.

Heat welding should not be used in areas where there are noticeable temperature changes that cause the panels to expand and contract. These are environments where the nature of the activities taking place cause temperature changes such as kitchens and showers.

When heat welding, a small area should be heat welded and inspected for client approval prior to proceeding with entire installation.

7.2 - Two-part Joint Strip Installation

1. Once the panel is in position, slide the back part of the two-part joint strip under the installed panel. Leave a small gap (about 1mm) between the panel edge and the centre part of the back side of the joint strip (there is a slightly indented line in the strip to use as a guide). If a transition strip is to be used to create a horizontal joint between the panel and the vinyl floor finish, the back part of the vertical strip should be cut short to allow the horizontal transition strip to be fitted at the base of the panel.

2. When forming the front cover around internal and external corners, the back of the trim should be carefully undercut to allow the trim to bend around the angles.

3. After this procedure has been completed, install the next BioClad panel in the sequence. Finish by installing the front cover section of the two-part joint strip.

4. The front joint strip covers should be initially positioned by hand pressure. They can then be fully set in place by tapping with a rubber mallet or a hand roller.

7.3 - Single-part Joint Strip Installation

The process of the single-part joint strip is similar to the two-part joint strip except that during preparation, a small chamfer / bevel will need to be applied to the edges of the panel where the joint strip is fit onto the panel. This will enable the single-part joint strip to be fitted more easily to the panel. The joint strip has a moisture resistant gasket seal on the inner edges which could be damaged if forced onto the panel.

1. Bevel the panel edges where the joint strips will be used (use an electric or hand file, a small block plane, or a Skarsten scraper to bevel the panel edges).

2. Fit the joint strip onto the leading edge of the panel. Tap the joint strip all the way onto the panel.

3. Apply tape and adhesive to the back of the panel remove the protective film from the double-sided tape, and install the panel onto the wall.

4. Prepare the next panel ensuring that edges are chamfered, install a joint strip to the leading edge of this panel (tap joint strip all the way into and seated against the panel).

5. Apply tape and adhesive to this panel and remove the protective film from the double-sided tape.

6. Install the panel that has just been prepared. This panel is set onto the wall so it overlaps the back leg of the previous joint strip. Remember to use the datum/level lines to set the height.

7. Use a tapping block or plastic stair tool (chisel) to adjust the joint strip sideways so it overlaps the two panels equally (make sure the joint strip is straight and level). Start at the top and work your way down the strip.

As a summary of the single-part joint strip installation; install the panels in sequence from left-to-right and fit a connector strip to the right side of each panel before you place it on the wall. After two panels are fit to each other, the joint strip is then tapped over and onto the right hand side panel being installed. A tapping block or plastic stair tool (chisel) must be used to adjust the joint strip sideways so it overlaps the attached panels equally.

7.4 - Heat Welding Installation

1. Remove burrs from panel edges, leaving a slight bevel at the edge to be welded.

2. Apply 2" wide double-sided foam tape on the wall so it is centred at the seam. Apply adhesive and install panel to the wall.

3. As you place the adjoining panels on the wall, allow a 1/16" (1.5mm) gap between each panel.

4. Clean both the seam area and the weld rod with a safe solvent cleaner - one that will not attack the vinyl or leave a film.

5. Wait until temperature and speed have been satisfied.

6. Test weld on a scrap piece of BioClad before proceeding. Refer to 7.1 "Jointing Methods Overview" for "Heat Weld" concerning approval of weld.

7. The weld may be trimmed flush when semi-cooled using the round part of the trimming spatula.

7.5 - Wall to Floor Transition Strip

The transition strip is fitted to connect a panel to the flooring. As described previously, the vertical joint strips are cut shorter than the full panel length. To find the correct length of the vertical section required, use a small piece of transition strip (as a template) and fit this to the bottom of the panel. Then measure the length of the vertical joint strip required and fit.

Section 8 – Cleaning

Initial Cleaning

Once all panels and joints are installed, remove the protective film and clean all surfaces down with antistatic solution or antistatic wipes. This is required as the panel may have static build up and any dust in the atmosphere will adhere to the surface of the panel.

Regular Cleaning

- BioClad can be cleaned with a diluted soap/detergent solution.
- When cleaning the Bioclad surface, we recommend the temperature of water does not exceed 140°F (60°C).
- Pressure cleaning with hot water may be used with the pressure nozzle a minimum of 2 feet (600mm) away from the surface.
- To reduce the build-up of static, cleaning the panels with anti-static solution is recommended,
- For stubborn stains use alkaline cleaner.
- Some cleaning agents may adversely affect BioClad.
- Do not use materials containing abrasives or solvents.

Cleaning Agents

Antistatic solution can be obtained from a variety of cleaning product manufacturers. Some antistatic solutions for walls can also be used on BioClad Walls.
Section 8 - Cleaning

Section 9 - Safety Procedures

Apart from the normal health and safety rules employed within the industry, the following rules should be noted:

- Safety information displayed on all materials must be strictly adhered to.
- Wear appropriate safety equipment (check with local federal OSHA regulations).

- Safety eye wear must be worn when cutting materials, mixing of adhesive, cleaning and preparation of site, and where necessary to adhere to site regulations.

- Use face masks and all appropriate safety shoes, clothing, and all other items that are required by local, state and/or federal guidelines and regulations.

- Ensure good ventilation, provide forced air if required.

- Remove and dispose of waste as per all local, state and federal guidelines and requirements.

- Wear protective gloves.

Operating temperature

BioClad will withstand service temperature of up to 140°F (60°C). If cleaning with hot water, temperature should be regulated to a maximum of 140°F (60°C) and not to be localised.

Stainless steel panels

Use stainless steel panels for temperatures over 140°F (60°C) for use near deep fryers/gas cookers/wall mounted grills/back vented ovens etc. Also portable items i.e. kettles/toasters/microwave ovens and back - vented commercial type.

Suitable surfaces

(Check adhesive data for specific requirement)

1. Good quality, brick or blockwork with well aligned joints and all irregularities repaired and made smooth. Must be straight to within 1/8" over 6 feet and bricks/blocks flush with those adjacent
2. Plaster, sand, and cement rendering 1:3 to a steel trowel finish.
3. Sheetrock/plasterboard.
4. Plywood.
5. Dense wood
6. Ceramic tiles are securely bonded to the substrate.
7. Most sound painted surfaces (an adhesive test is advisable to ascertain suitability).
8. New sheetrock, plaster, and pink finishing plasters are generally dusty. Surfaces to be brushed and thoroughly sealed with diluted PVA primer.

Surface Preparation

1. All substrates to be dry to 16% WME (wood moisture equivalent) on protimeter Survey master' equipment.
2. All loose flaking paint and dust to be removed.
3. Friable surfaces to be removed or made sound
4. All surfaces to be free from grease and ceramic tiles to be thoroughly degreased, rinsed and left to dry.
5. All loose tiles are to be removed and area is to be made good using repair mortar, sand, cement or plywood infill.
6. Depressions in substrate surface should be filled with repair mortar, sand, cement or plywood infill.

Installation temperature

BioClad recommends that the sheet is installed at approximately the ambient service temperature at which the room area will be when commissioned.

This is to ensure that expansion parameters are not exceeded. Normal expansion is provided for in the fining of the material within the joint strips and the silicone mastic seals at abutments.



BioClad accessories – transition strips

Advanced BioClad® Single Skin PVC Panel

Installation and Fitting

Installation

Advanced PVC is a very versatile system which can be easily installed in almost any building.

Wall Preparation

Walls should be level and flat. Remove high spots and fill low spots. Advanced adhesive can be applied to any solid wall or wall surface, eg plaster, gypsum, board, brick, poured concrete, concrete block etc. It can also be applied directly to tiled surfaces that are firmly fixed to the wall. All surfaces must be dry and clean.

Cutting

A jigsaw is the best method of cutting the sheeting. A fine toothed hand saw can also be used.

Joining

Fully sealed joints are made using Advanced high impact PVC Silicone free gasket trim system which incorporates a co-extruded seal unique to Advanced. Joints can also be welded upon request.

Internal/external corners

Advanced PVC is normally thermoformed on site, so window and door reveals are neatly clad without an edge joint.

Fixing

Sheets are fixed using a fully bonded method with a trowel for advanced adhesive (or gun applied polymer adhesive subject to wall substrate).

Advanced Panel Adhesive

This provides a quick and simple method to fit hygienic PVC cladding to most substrates. This polyurethane adhesive is applied to the back of the panels or onto substrate to give a solid all over bond.

The adhesive is easy to spread and should be applied with a notched trowel (see diagram). To ensure a 100% transfer of adhesive, apply firm, even pressure to the complete surface area when the panels are offered to the wall.

Fitting

PVC 'H' Trim Single Part

This high impact PVC co-extrusion is fixed to walls and the sheets pushed into each section. The silicone free gasket joint ensures a water-tight seal that can be power hosed or handwashed and will provide a full sealed easy clean finish.

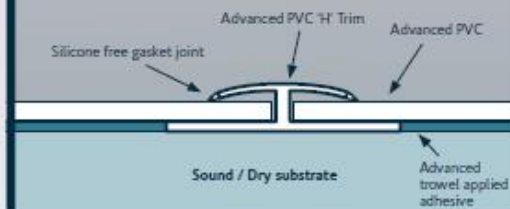

End stop / 'J' Trim

Manufactured and installed as the Advanced PVC 'H' trim. Can be used at the top, bottom and when starting / finishing cladding.



PVC 'H' Trim Welded

BioClad® (or Advanced PVC) can be cold or hot welded along its length to provide a sealed finish. N.B Not suitable for high temperature range changes.

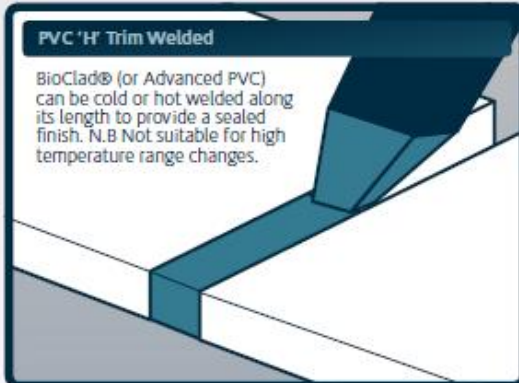

PVC 'H' Trim 2 Part

This high impact PVC co-extrusion is fixed to walls and the sheets pushed into each section. The silicone free gasket joint ensures a water-tight seal that can be power hosed or handwashed and will provide a full sealed easy clean finish.

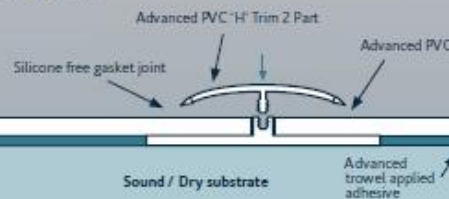

Fitting

Internal / External corners

Most cladding is fabricated on site and angles are carefully routed and thermoformed to give a smooth, easy to clean strong finish.

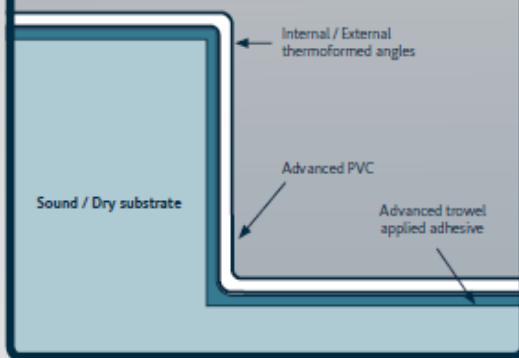

Window / Door openings

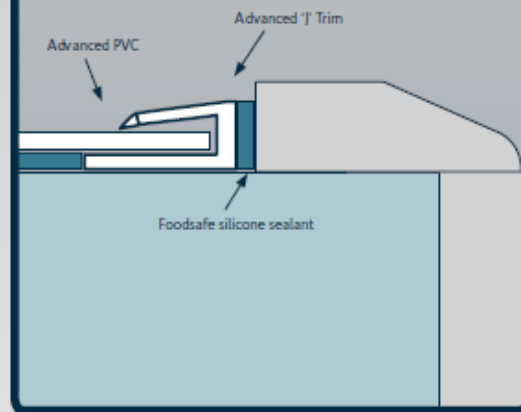

Resin floor detail

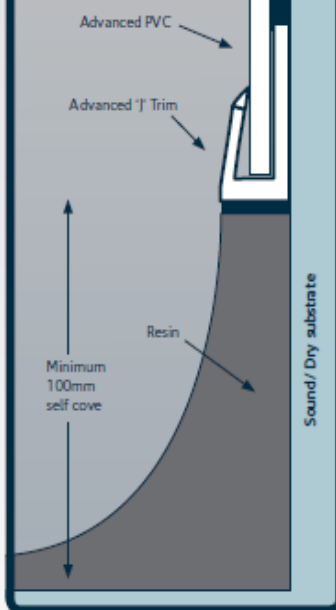

Vinyl floor detail

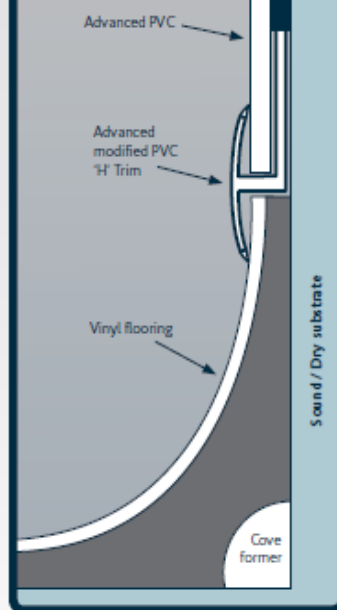

Quarry tile floor detail

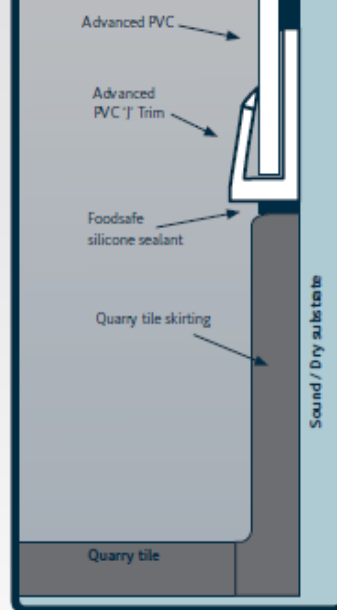

BioClad two-part joint strip

The main features of the new BioClad and joint/transition strips are as follows:

- A narrower and flatter extrusion
- Tighter finished joints - a two part extrusion
- Improved installation methods
- Increased hygiene levels incorporated into the manufacturing process
- Improved installation when used in conjunction with safety flooring
- Easier and quicker to repair in the event of damage only replace the front cover

Fitting the two-part joint strip:

- Apply first sheet of BioClad to the wall
- Cut to length, if required
- Slip backing strip behind edge of first sheet
- Ensure edge of sheet is lined up with the marked line on backing strip
- Apply second sheet
- Ensure edge of second sheet is lined up with marked line on backing strip
- Cut front cover to length allowing for cut tile transition if required
- Snap front cover to backing strip
- Ensure male barbed front cover is completely housed in to the female backing strip
- Use either a rubber mallet or roller to ensure full contact between front cover and sheet

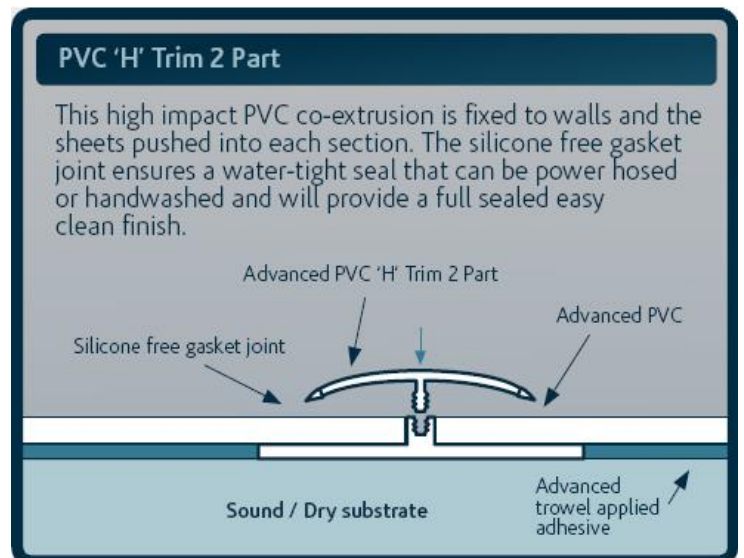

BioClad wall system to Flexi joint detail

BioClad hygienic wall system 2.5mm thick is installed over most sound, dry substrates, with the appropriate BioClad adhesive and double sided tape.

Joint gaps formed (3.4mm) width by using metal spacer bars for parallel edges. Apply a uniform bead of polymer sealant within the gaps. Insert flexi joint trim into the gap and roll with a small hand roller.

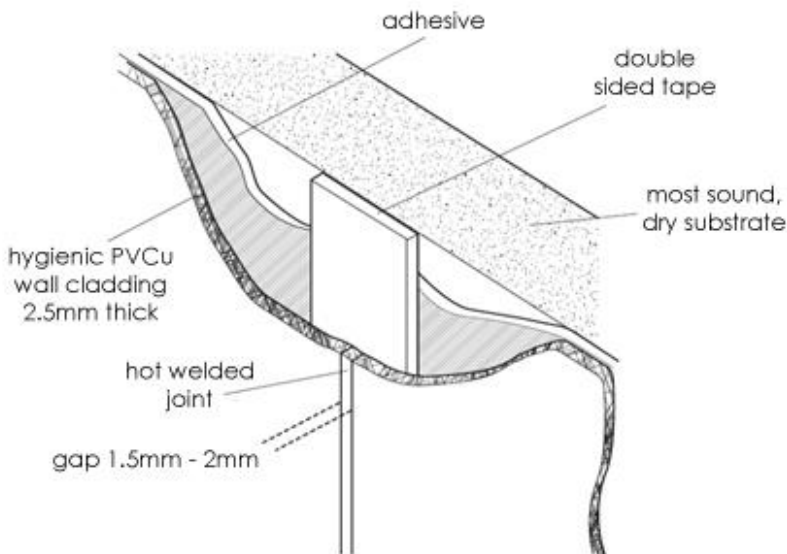

Fitting the FlexiJoint Profile

Prepare and fix the BioClad panel as described in this guide.

-Prepare the next panel as before then dry fit this panel to check that the joint between both true and parallel

- Against the leading edge, temporarily fix three metal spacer bats (top, middle, and bottom) to set the gap between the panels about (3.4mm) width.

- Prepare and fit the next panel using the same procedure as previously described. Leave the protective cover on the strip of double-sided tape which butts against the metal spacer bars (this will allow for easier fitting when butting uptight to the spacer bars).

-Roll the panel to transfer the adhesive thoroughly to the substrate then remove the metal spacer bars.

-Ease out the edge of the panel to allow the protective cover to be removed from the double-sided tape.

-Press the panel back down to the substrate and reroll.

Fitting the Flexi Joint Profile

- Apply a uniform bead of polymer sealant to the substrate in between the joint gap – max (2 mm) bead.

- Cut a length of Flexi Joint slightly oversize for the joint and then push firmly into the joint gap.

- Once the profile has been fully fitted to the joint, roll the joint thoroughly with a small hand roller.

- Trim off the surplus as required.

- Door heads, windows heads and sill sections need to be carefully scribed and cut to adjacent panels to ensure a gap of (3.4mm) width is maintained for the Flexi Joint profile.

Recommended tools for cutting panels

Due to the tight fitting of the Flexi joint profile, it is important that the panel edges are smooth, square, true, and free from burrs.

- Jigsaw with a fine tooth cutting blade - ensure the panel is cut slightly oversize and then bent to a crisp, clean, square edge.

- Circular saw - use the fine toothed cutting blades (for plastics) with cutting guide.

- Router cutter - use straight edge router bits (for laminates) with cutting guide.

BioClad Heat Welded System

Substrates

When installing BioClad panels with welded joints, it is imperative the substrate is in good condition. Surfaces must be sound and level. Recommended substrates include plasterboard, plywood, finishing plaster and most types of sand & cement.

Planning Layout

When planning the layout of the panels it is important to minimise the number of joints in the wall system. Ensure joints do not fall too close to corners. This will avoid any alignment problems between the joint when the next panel is fitted.

Preparing the joint

Before installing the panels, you must fit the double-sided tape to the substrate at the centre point where the two panels meet.

Panel Preparation

Ensure all panel edges (where joints are to be formed) are clean, smooth, true and level. Always inspect new panel edges to check they are undamaged or scored.

When cutting panels, you should always cut panels fractionally long and then plane to 3 'crisp' square edge.

Check that there is no loose debris left on the edge of the panel from where it was cut. This debris could burn when hot welding the joint and will leave a blemish which can't be removed from the joint.

When preparing the fitting of the panel, always ensure there is an adequate gap between the panel and any rigid abutments (ceiling, windows, doors, services etc) to allow for expansion.

Adhesives

BioClad recommends Advanced adhesive for all welded installations.

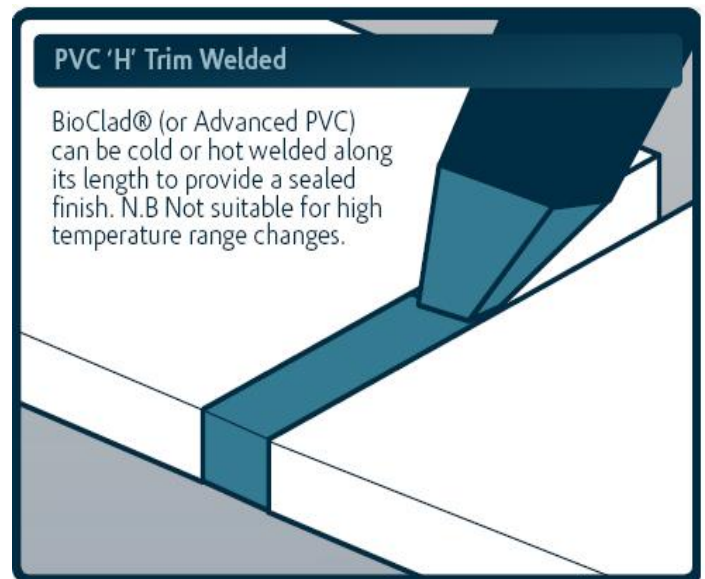

Application Methods

After fitting the double-sided tape, leave the protective top film in place (this will be removed later). Once the panels have been prepared and dry fitted to check everything is correct, apply the adhesive to the back of the pane. Install the panel in the normal way, ensuring the panel is temporarily supported on wood blocks (or similar) to prevent slipping. Check that the panel is aligned with the datum line before rolling the panel to achieve a transfer of the adhesive to the substrate. When rolling the panel, start in the middle and work outward. At this stage do not roll right to the edge where double side tape is located.

Once the panel has been rolled (almost to the edge), carefully cut down along the edge of the panel where the tape is located and cut through the tape's protective top film. Carefully ease the edge of the panel to facilitate the removal of that half of the protective top film. Once this has been removed, press the panels firmly onto the tape to achieve a full bond. Finally, complete the full rolling of the panel right up to the edge to ensure good transfer of the adhesive.

Prepare the next panel in the same way as described above. Before fitting this panel you must fit a series of 'spacer pins' against the edge of the previous panel. This is to provide the correct 'gap spacing' between each panel. A spacer pin is anything from a finish nail (on gypsum board and drywall) to the thickness of a penny (on concrete or cement block) that provides the correct amount of space between each panel.

Fit the next panel as described above, ensuring the panel is butted tightly to the spacer pins. Once the panel has been rolled almost to the edge, remove the spacer pins and then remove the final part of the double-side tape's protective cover. Press the panel firmly onto the foam tape and then complete the rolling of the panel.

Check that all edges are clean and free of adhesive residue. Once the installation of the panels is complete, you are then ready to weld the joints. On larger jobs, you can weld the panels as you go'. However, we recommend welding does not take place until the adhesive has completely set up. (Usually the next day).

Hot welding

Ensure your weld rod and the joint gap to be welded is clean and free of dust and contamination.

The hot welding technique used to weld BioClad panels is largely similar to that used in with sheet flooring. The same type of tools and welding gun can be used.

Trimming Off Excess Weld rod

This is often the part of the job which can be most difficult because you are welding a plain, smooth wall finish, which can highlight any imperfections in your work.

After completing the welded joint you should pre-cut the Joint using the spatula trimming knife (also known as the quarter moon knife). During this process, apply a liberal amount of 'Antistatic solution' sprayed on to the joint before any trimming takes place. This will reduce any friction between the cutting blade and the panel and minimize the risk of scratching the panel.

After pre-cutting the weld rod, allow the rod to cool down sufficiently before completing the final trimming.

Once the rod has cooled down (cold) you can commence final trimming with the spatula. Take care not to scratch or damage the BioClad surface while undertaking this final part of the operation.



BioClad to door frame architrave detail

BioClad hygienic wall system to door fixed with 2 double sided-tape and Advanced Adhesive to most sound and dry wall substrates, sealed with silicone sealant.

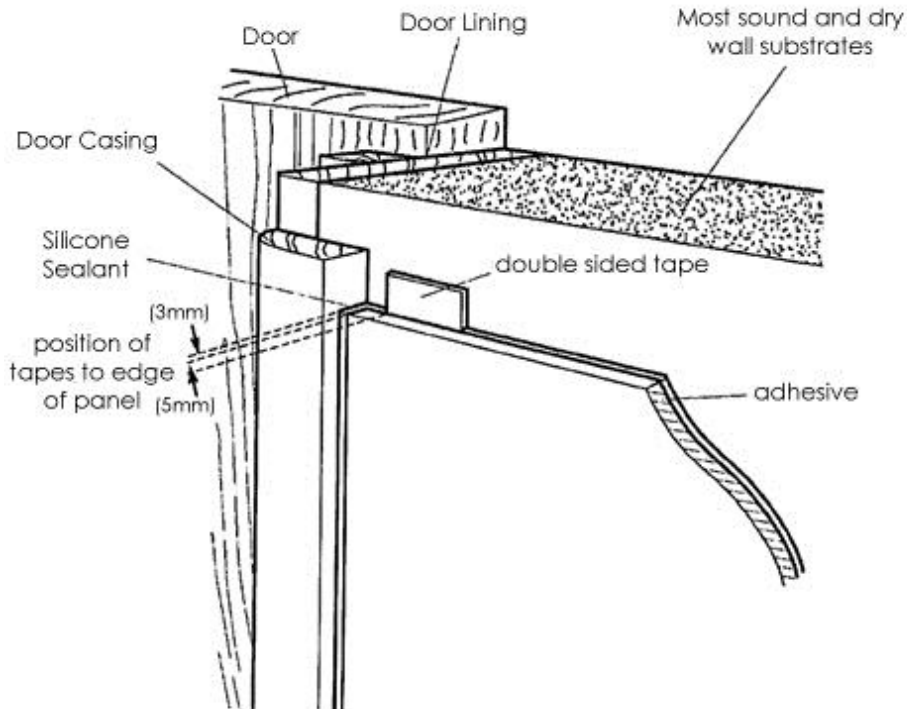

BioClad hygienic wall system 2.5mm thick is installed over most dry substrates, to quarry tile base/skirting (typical 100mm by 12mm thick) with similar floor tiles fixed with appropriate Advanced Adhesive and double-sided tape sealed with silicone sealant.

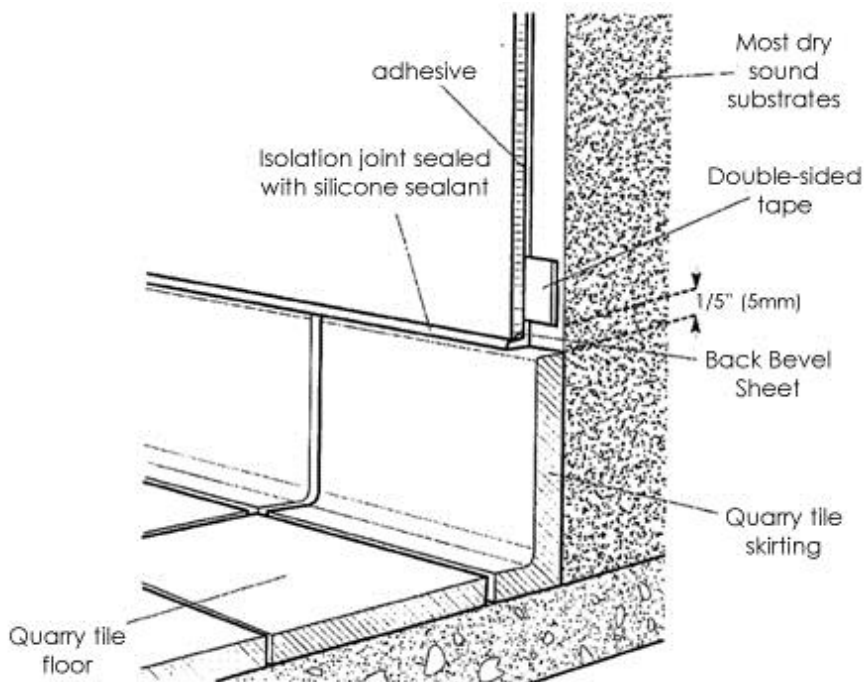

BioClad hygienic wall system installed to glazed tiles detail

BioClad hygienic wall system installed over sound, well adhered, ceramic wall tiles with plywood infill uses Advanced Adhesive and double-sided tape and sealed with silicone sealant.

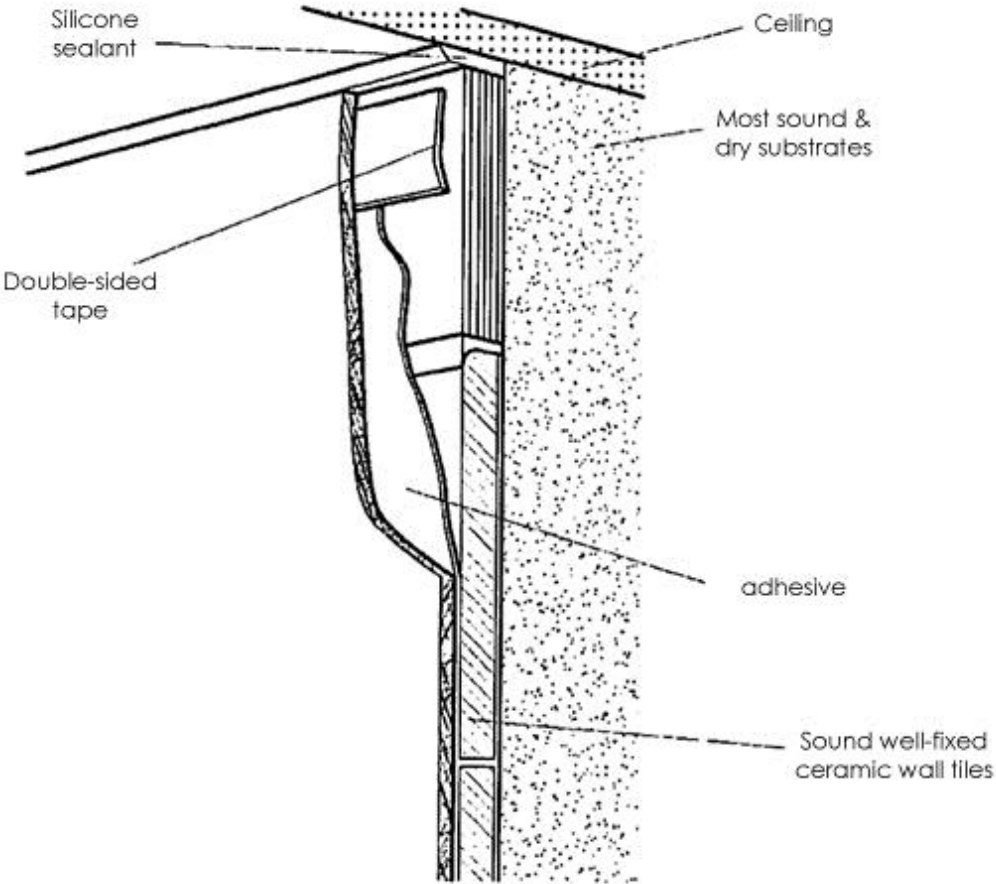

BioClad stainless steel panels to stainless steel panels

BioClad stainless steel panels, installed over most sound, dry substrates fixed with Advanced Adhesive for hot areas where surface temperatures exceed 140° F (60° C). Panels joined with stainless steel strip. Seal stainless steel trim with clear silicone sealant.

